



**INSTRUCTIONS D'ASSEMBLAGE**  
**ASSEMBLY INSTRUCTIONS**

---

**M**ONARCH  
SPECIALTIES INC.

# I 8044

---

**CHAISE D'APPOINT -**  
**TISSU " HEXAGONALE " GRIS / BRUN**

**ACCENT CHAIR -**  
**GREY / EARTH TONE " HEXAGON " FABRIC**



**POUR DE L'ASSISTANCE OU POUR COMMANDER**  
**DES PIÈCES CONTACTEZ NOTRE DÉPARTEMENT**  
**DE SERVICE À LA CLIENTÈLE.**

**FOR ASSISTANCE OR TO ORDER PARTS**  
**CONTACT OUR CUSTOMER SERVICE DEPARTMENT**

**WWW.MONARCHSERVICE.COM**

**LISTE DES PIÈCES**  
**PARTS LIST**

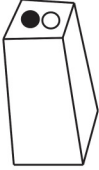
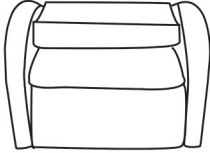
PIÈCE / PART #	IMAGE	DESCRIPTION	QTY / QTÉ
1		LEG PATTE	4
2		SEAT SIÈGE	1

**LISTE DES PIÈCES DE MONTAGE**  
**HARDWARE LIST**

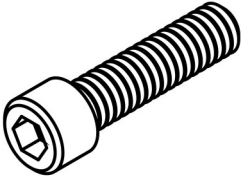
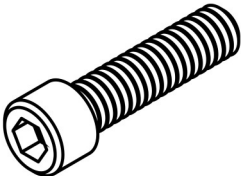
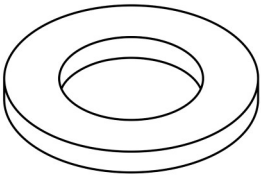
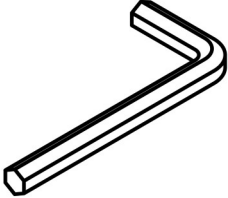
PIÈCE / PART #	IMAGE	DESCRIPTION	QTY / QTÉ
A		ASSEMBLING BOLT - Ø 3/8" X 2 1/4" BOULON D'ASSEMBLAGE - Ø 3/8" X 2 1/4"	1
B		ASSEMBLING BOLT - Ø 3/8" X 4 3/4" BOULON D'ASSEMBLAGE - Ø 3/8" X 4 3/4"	4
C		METAL WASHER RONDELLE DE MÉTAL	1
D		HEX KEY CLÉ HEXAGONALE	1

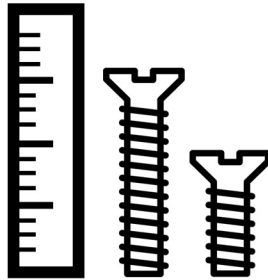

OUTIL DE VÉRIFICATION DE DIMENSIONS DES PIÈCES  
HARDWARE DIMENSIONS VERIFICATION TOOL

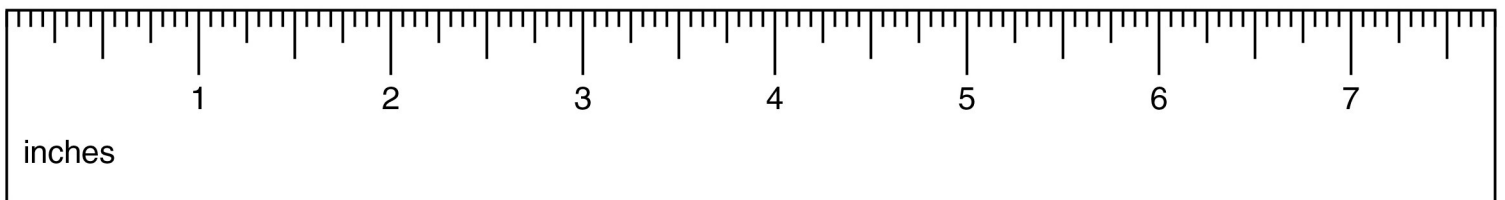

**ÉTAPE / STEP 1**

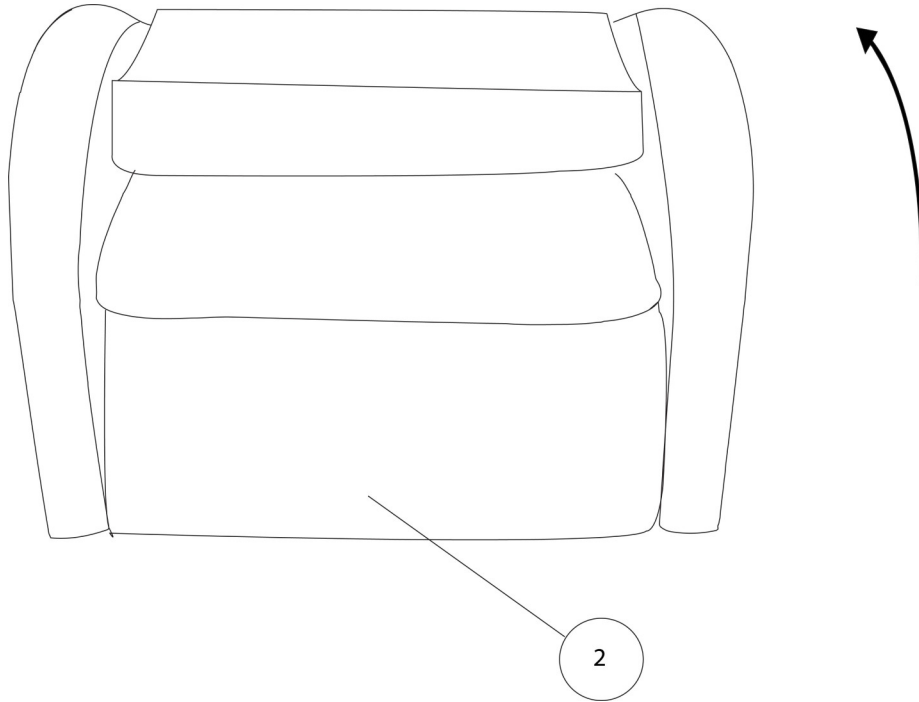

**ÉTAPE / STEP 2**

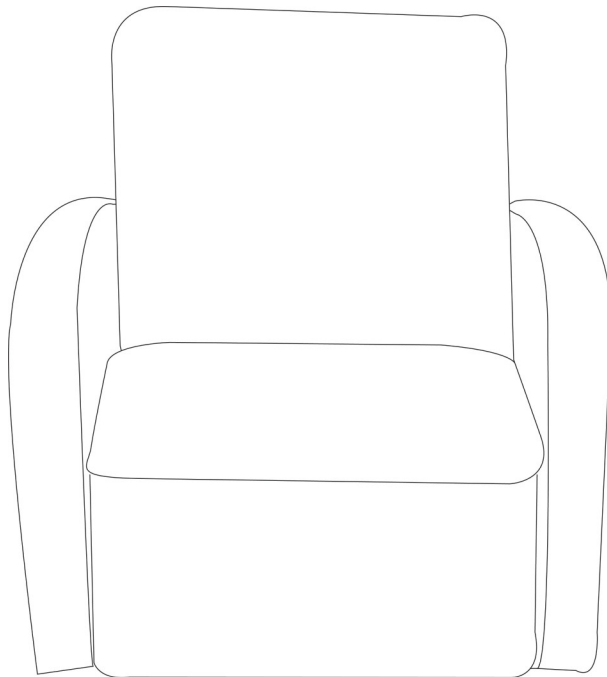

VUE AVANT /  
FRONT VIEW

**ÉTAPE / STEP 3**

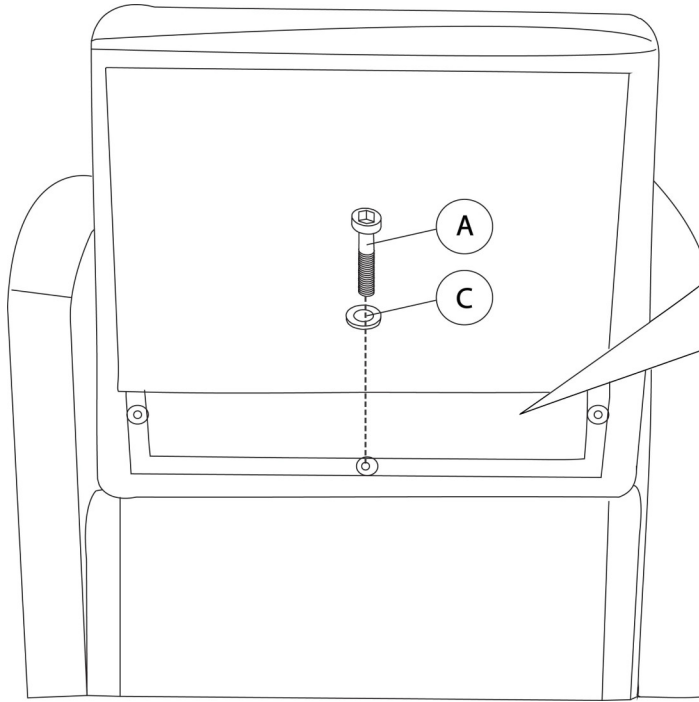

La quincaillerie et les pattes sont  
entreposées dans le compartiment  
en-dessous de l'unité.

Hardware and legs are located in the  
compartment under the unit

**ÉTAPE / STEP 4**

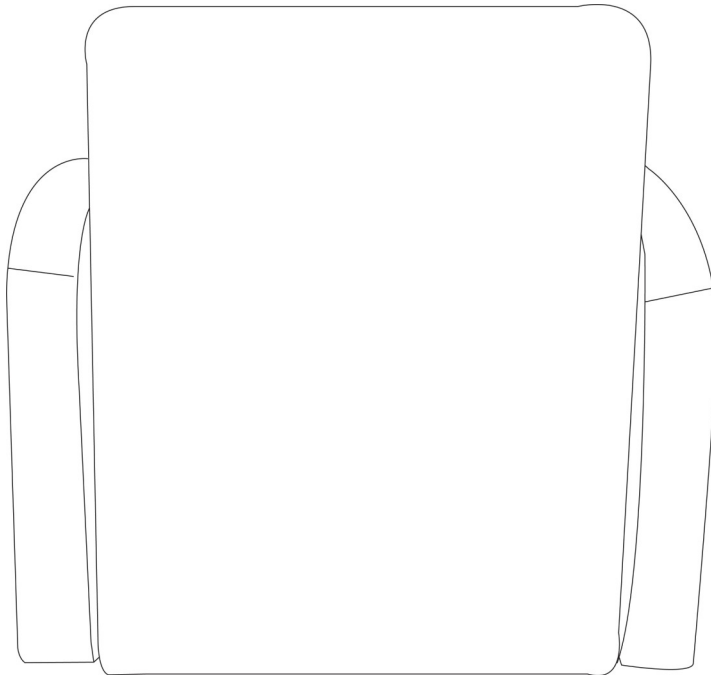

VUE ARRIÈRE /  
BACK VIEW

ÉTAPE / STEP 5

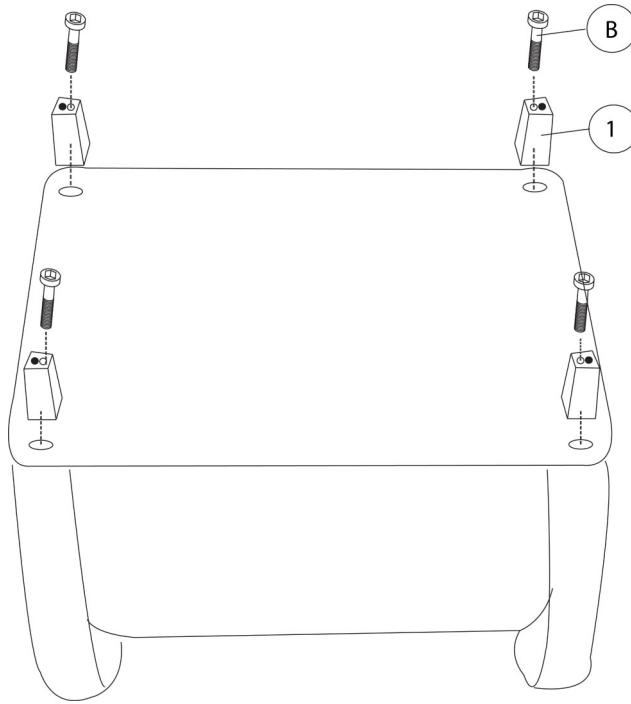

ÉTAPE / STEP 6

