

ASSEMBLY INSTRUCTIONS INSTRUCTIONS DE MONTAGE

SIDEBOARD

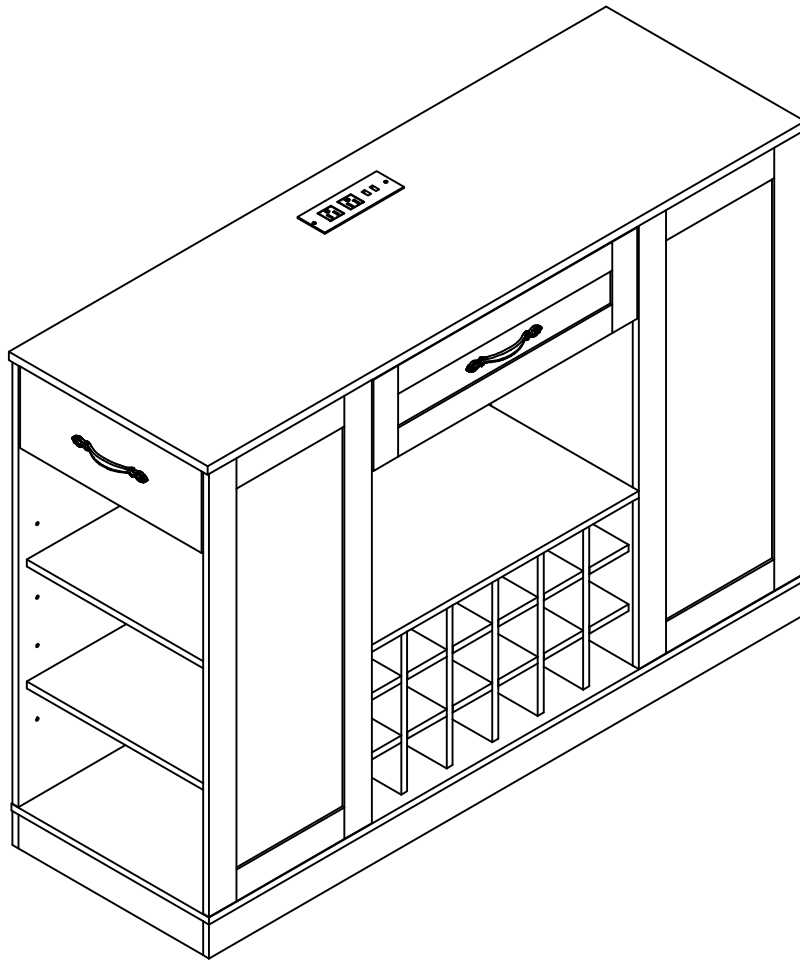

N889P443149

⚠ WARNING		⚠ AVERTISSEMENT	
	This product is NOT a Clothing Storage Unit (CSU). DO NOT use it for clothing storage. Improper use may cause furniture tipover.		Ce produit NEST PAS une unité de rangement pour vêtements (CSU). NE l'utilisez PAS pour le rangement de vêtements. Une utilisation impropre peut entraîner un basculement des meubles.

Detail View / Vue détaillée

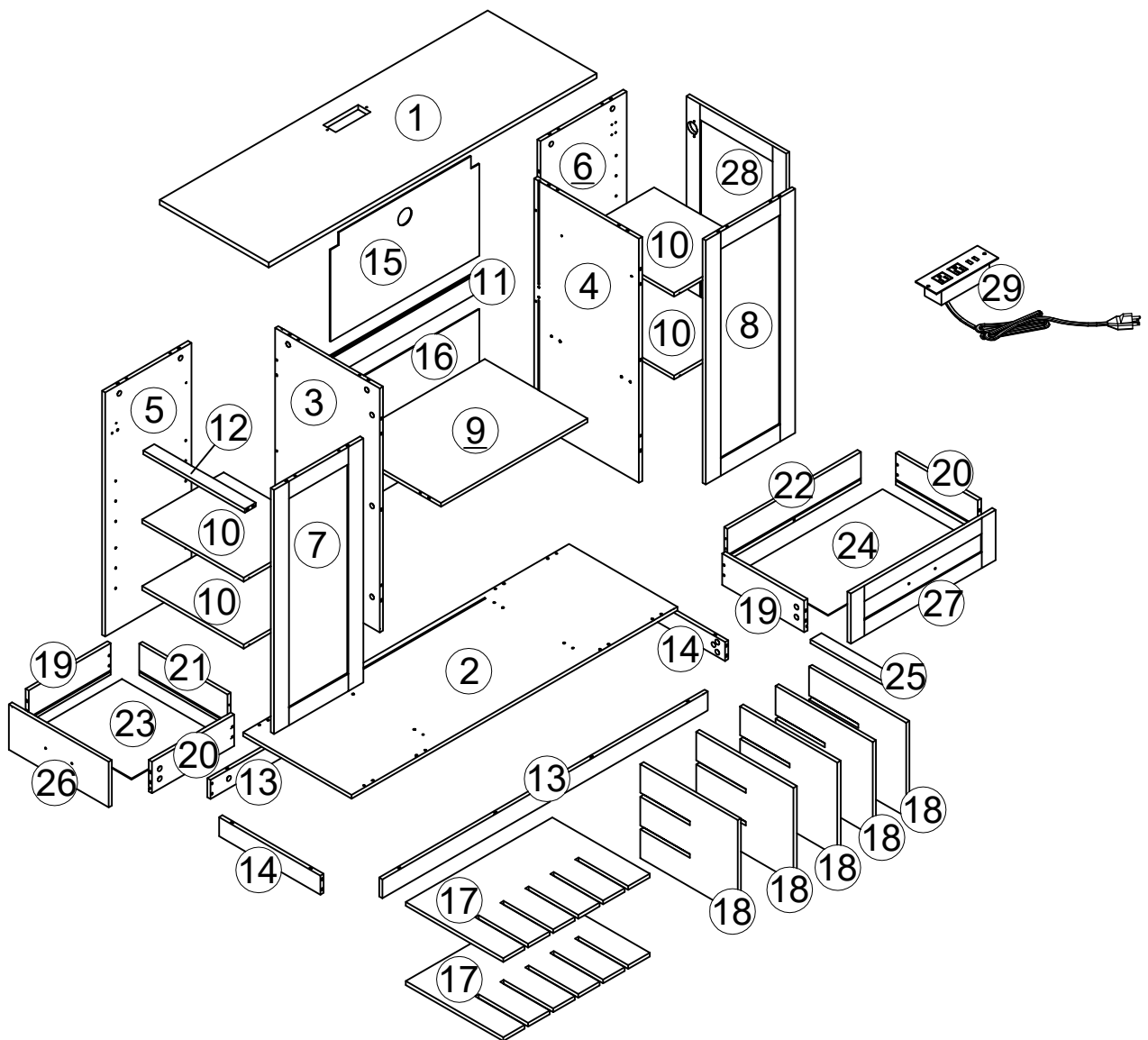

Part List / Liste des pieces

N889P443149

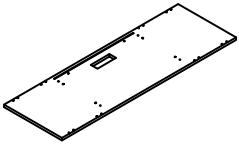
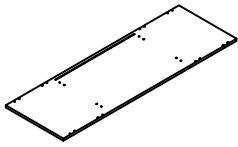
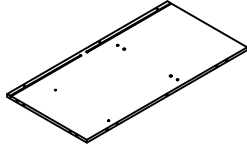
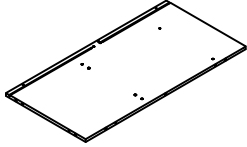
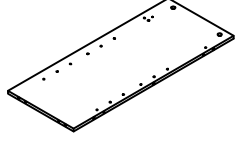
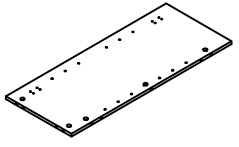
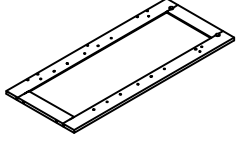
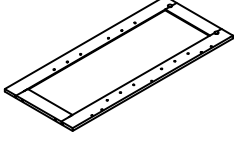
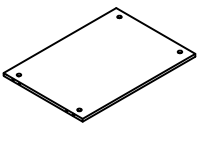
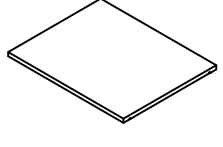
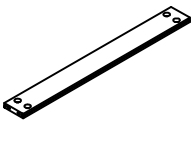
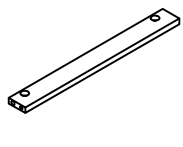
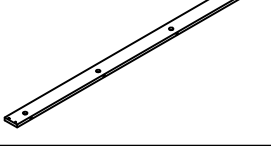
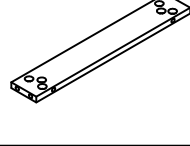
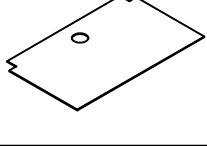
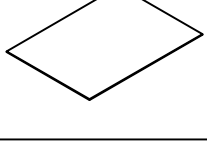
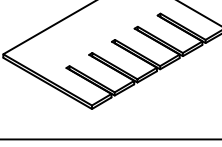
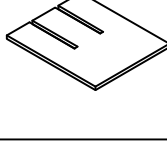
<p>①</p> 	<p>②</p> 	<p>③</p>  <p style="text-align: right;">L</p>
<p>Top Panel (1 pcs) Panneau superieur (1 pièces)</p>	<p>Bottom Panel (1 pcs) Panneau inferieur (1 pièces)</p>	<p>Middle Side Panel (1 pcs) Middle side panel (1 pièces)</p>
<p>④</p>  <p style="text-align: right;">R</p>	<p>⑤</p> 	<p>⑥</p> 
<p>Middle Side Panel (1 pcs) Middle side panel (1 pièces)</p>	<p>Left Rear Panel (1 pcs) Panneau arriere gauche (1 pièces)</p>	<p>Right Rear Panel (1 pcs) Panneau arriere droit (1 pièces)</p>
<p>⑦</p> 	<p>⑧</p> 	<p>⑨</p> 
<p>Left Front Board (1 pcs) Plaque avant gauche (1 pièces)</p>	<p>Right Front Panel (1 pcs) Panneau avant droit (1 pièces)</p>	<p>Middle Layer Board (1 pcs) Plaque de couche moyenne (1 pièces)</p>
<p>⑩</p> 	<p>⑪</p> 	<p>⑫</p> 
<p>Adjustable Shelf (4 pcs) Étagère réglable (4 pièces)</p>	<p>Thick Backplate (1 pcs) Plateau arriere épais (1 pièces)</p>	<p>Auxiliary Panel (1 pcs) Panneau auxiliaire (1 pièces)</p>
<p>⑬</p> 	<p>⑭</p> 	<p>⑮</p> 
<p>Skirting Panel(2 pcs) Panneau de jupe (2 pièces)</p>	<p>Skirting Panel(2 pcs) Panneau de jupe (2 pièces)</p>	<p>Thin Backplate (1 pcs) Plate arriere mince (1 pièces)</p>
<p>⑯</p> 	<p>⑰</p> 	<p>⑱</p> 
<p>Thin Backplate (1 pcs) Plate arriere mince (1 pièces)</p>	<p>Red Wine Partitionr (2 pcs) Partition de vin rouge (2 pièces)</p>	<p>Red Wine Partitionr (5 pcs) Partition de vin rouge (5 pièces)</p>





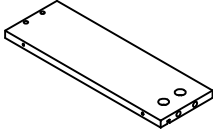
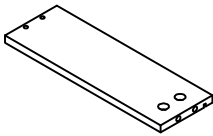
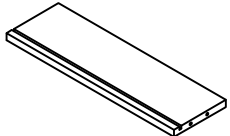
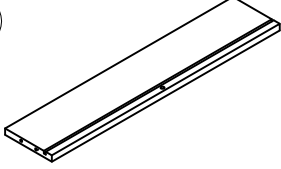
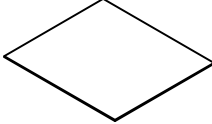
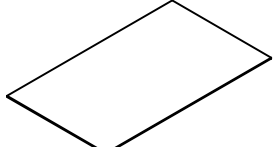
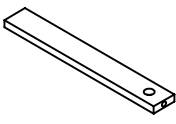
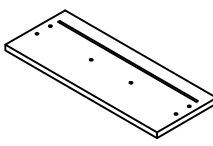
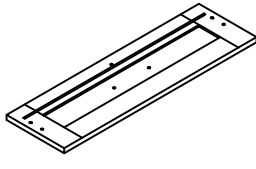
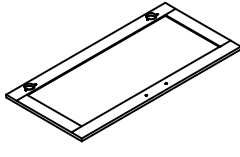
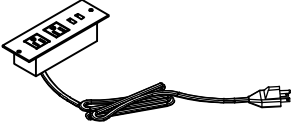





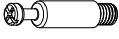

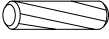





Part List / Liste des pieces

N889P443149

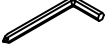
<p>19</p> 	<p>20</p> 	<p>21</p> 
<p>Left Side Panel Of Drawer (2 pcs) Panneau latéral gauche du tiroir (2 pièces)</p>	<p>Right Side Panel Of Drawer (2 pcs) Panneau latéral droit du tiroir (2 pièces)</p>	<p>Drawer Back Panel (1 pcs) Panneau arrière tiroir (1 pièces)</p>
<p>22</p> 	<p>23</p> 	<p>24</p> 
<p>Drawer Back Panel (1 pcs) Panneau arrière tiroir (1 pièces)</p>	<p>Drawer Bottom Panel (1 pcs) Panneau inférieur du tiroir (1 pièces)</p>	<p>Drawer Bottom Panel (1 pcs) Panneau inférieur du tiroir (1 pièces)</p>
<p>25</p> 	<p>26</p> 	<p>27</p> 
<p>Drawer Auxiliary Board (1 pcs) Panneau auxiliaire tiroir (1 pièces)</p>	<p>Drawer Panel (1 pcs) Panneau tiroir (1 pièces)</p>	<p>Drawer Panel (1 pcs) Panneau tiroir (1 pièces)</p>
<p>28</p> 	<p>29</p> 	
<p>Door Panel (1 pcs) Panneau de porte (1 pièces)</p>	<p>Socket (1 pcs) Socket (1 pièces)</p>	

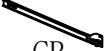
Hardware List / Liste du matériel

N889P443149

<p>(A)</p>  <p>Ø6*35mm</p>	<p>(B)</p>  <p>Ø15*9.5mm</p>	<p>(C)</p>  <p>Ø6*30mm</p>	<p>(D)</p>  <p>Ø5*40mm</p>	<p>(E)</p>  <p>Ø3.5*12mm</p>	<p>(F)</p>  <p>Plug the hole Ø20mm</p>
<p>Cam Bolt (57 pcs) Boulon a came (57 pièces)</p>	<p>Cam Nut (57 pcs) Ecrou a came (57 pièces)</p>	<p>Wood Dowel (38 pcs) Cheville en bois (38 pièces)</p>	<p>Bolt (27 pcs) Boulon (27 pièces)</p>	<p>Self-tapping Screw (34 pcs) Vis automatique (34 pièces)</p>	<p>Hole Stickers (7 pcs) Autocollants trou (7 pièces)</p>
<p>(G)</p>  <p>M4*16mm</p>	<p>(H)</p> 	<p>(I)</p> 	<p>(J)</p>  <p>Ø4*12&Ø6*30&Ø4*35mm</p>	<p>(K)</p>  <p>Ø3*16mm</p>	<p>(L)</p> 
<p>Handle Screw (4 pcs) Poignée vis (4 pièces)</p>	<p>Handle (3 pcs) Poignée (3 pièces)</p>	<p>Hinge (2 pcs) Charnière (2 pièces)</p>	<p>Anti-tip device (2 pcs) Dispositif anti-pointe (2 pièces)</p>	<p>Single Plastic Cap (8 pcs) Capuchon en plastique unique (8 pièces)</p>	<p>Shelf Support (Steel) (16 pcs) Support d'étagère (acier) (16 pièces)</p>
<p>(M)</p>  <p>S4</p>	<p>(N)</p>  <p>M4*8mm</p>	<p>(CR)</p>  <p>300mm</p>	<p>(CL)</p>  <p>300mm</p>	<p>(DR)</p>  <p>300mm</p>	<p>(DL)</p>  <p>300mm</p>
<p>Allen Wrench (1 pcs) Clé allen (1 pièces)</p>	<p>Handle Screw (2 pcs) Poignée vis (2 pièces)</p>	<p>Drawer Slide (2 pcs) Tiroir coulisse (2 pièces)</p>	<p>Drawer Slide (2 pcs) Tiroir coulisse (2 pièces)</p>	<p>Drawer Slide (2 pcs) Tiroir coulisse (2 pièces)</p>	<p>Drawer Slide (2 pcs) Tiroir coulisse (2 pièces)</p>

ASSEMBLY TOOLS REQUIRED (NOT INCLUDED) OUTILS D'ASSEMBLAGE REQUIS (NON INCLUS)



PLEASE BE CAREFUL DO NOT DAMAGE THE HOLE POSITION WHEN YOU USE POWER TOOLS !

FAITES ATTENTION À NE PAS ENDOMMAGER LA POSITION DE MAINTIEN LORSQUE VOUS UTILISEZ DES OUTILS ÉLECTRIQUES !

STEP 1 / ÉTAPE 1:

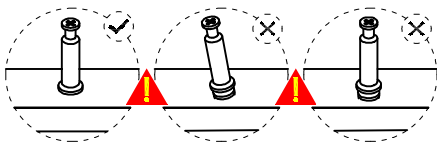
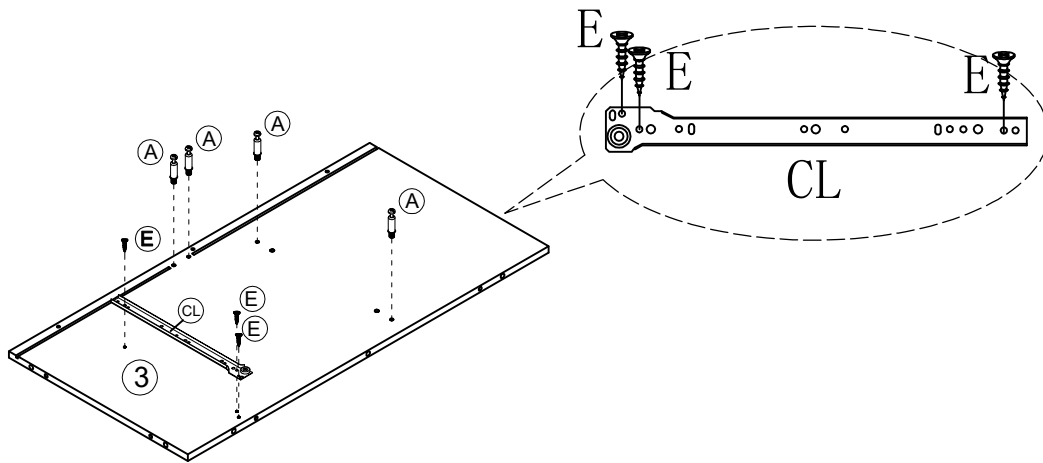

CL	X1	(E)	X3	(A)	X4
300mm		Ø3.5*12mm		Ø6*35mm	

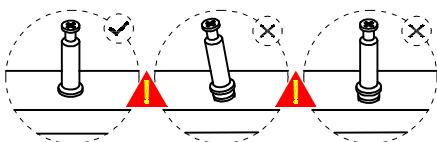
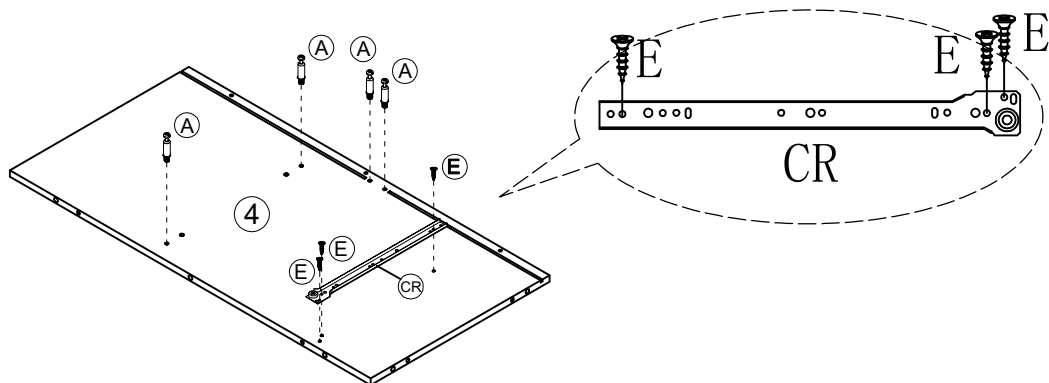

STEP 2 / ÉTAPE 2:



CR	X1	(E)	X3	(A)	X4
300mm		Ø3.5*12mm		Ø6*35mm	

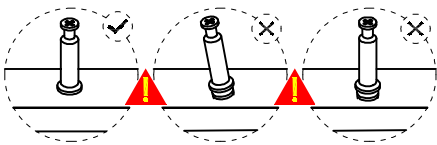
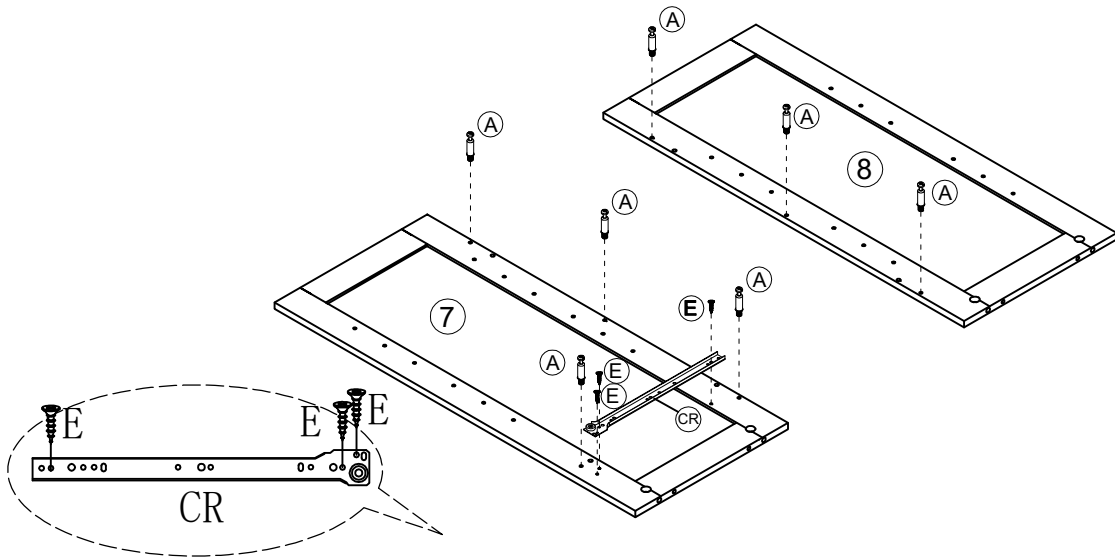

STEP 3 / ÉTAPE 3:

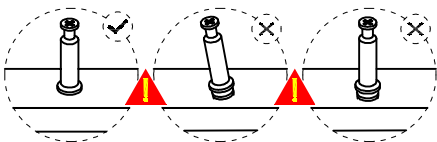
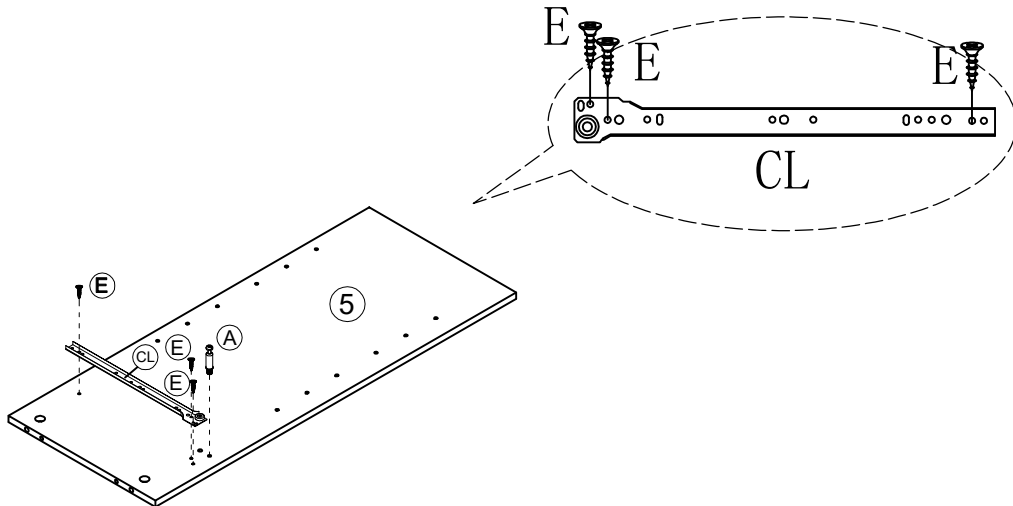

CR	X1	(E)	X3	(A)	X7
					
300mm		Ø3.5*12mm		Ø6*35mm	

STEP 4 / ÉTAPE 4:



CL	X1	(E)	X3	(A)	X1
					
300mm		Ø3.5*12mm		Ø6*35mm	

STEP 5 / ÉTAPE 5:

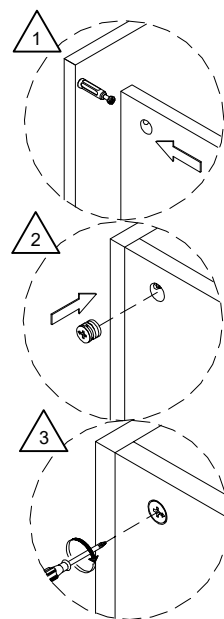
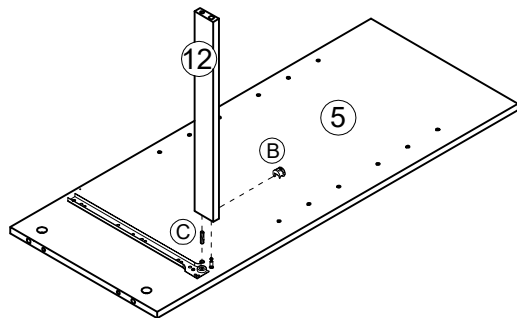

C	X1	B	X1
Ø6*30mm		Ø15*9.5mm	

STEP 6 / ÉTAPE 6:

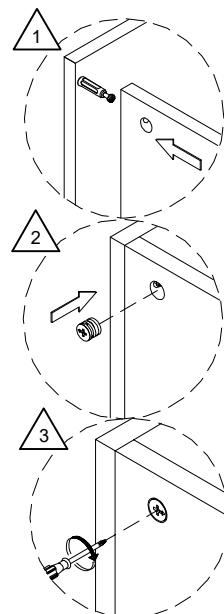
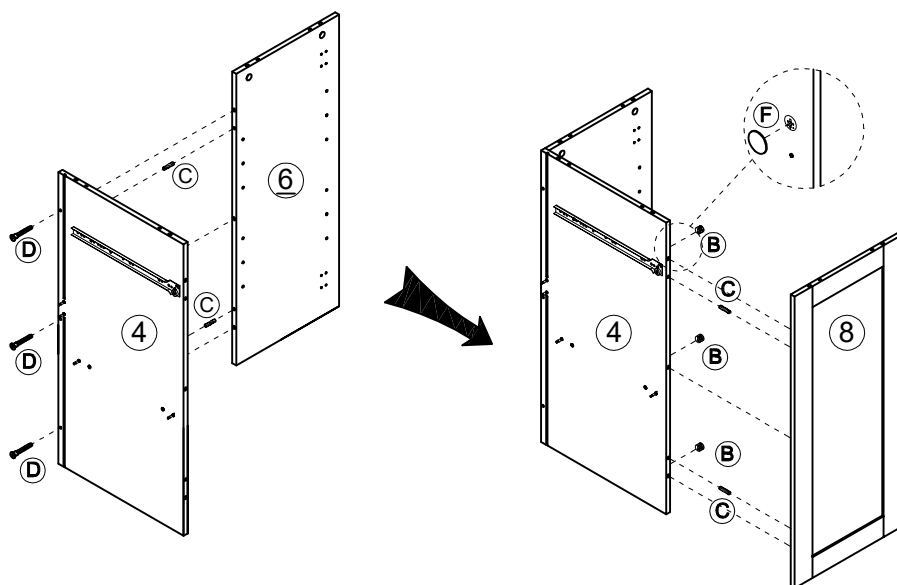

Note: After locking B, paste F.

Remarque : Après avoir verrouillé le B, collez le F.



F	X3	C	X4	D	X3	B	X3
Ø20mm		Ø6*30mm		Ø5*40mm		Ø15*9.5mm	

STEP 7 / ÉTAPE 7:

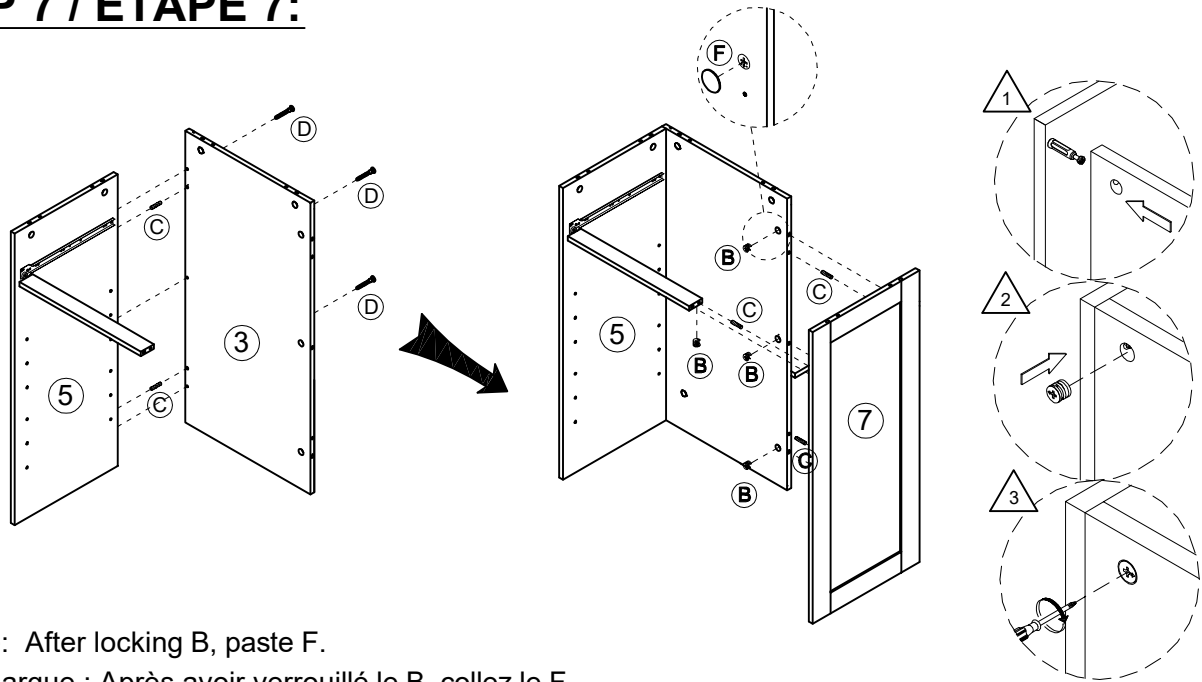

Note: After locking B, paste F.

Remarque : Après avoir verrouillé le B, collez le F.



F X3

F	X4	C	X5	D	X3	B	X4
Plug the hole							
Ø20mm		Ø6*30mm		Ø5*40mm		Ø15*9.5mm	

STEP 8 / ÉTAPE 8:

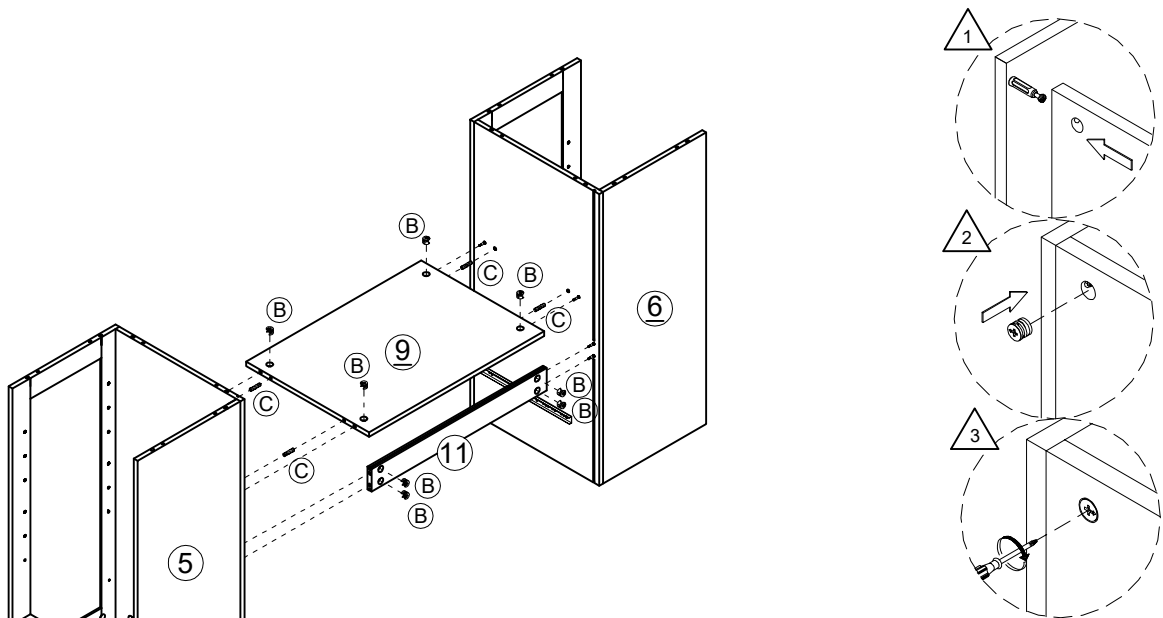

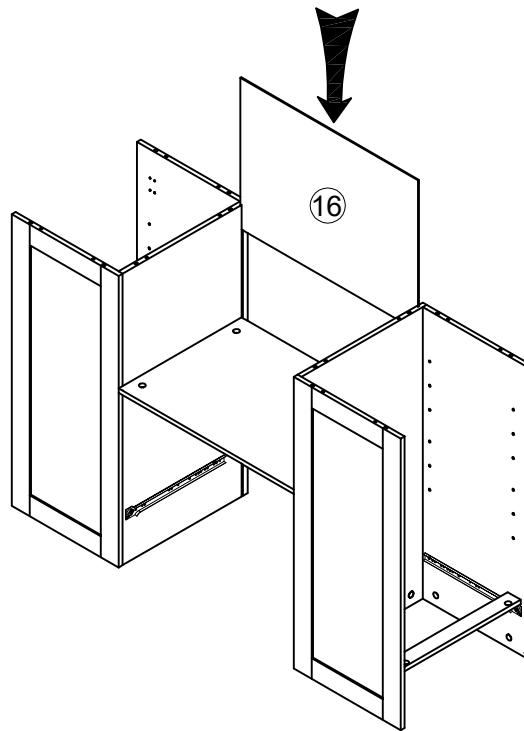

C	X4	B	X8
Ø6*30mm		Ø15*9.5mm	

STEP 9 / ÉTAPE 9:



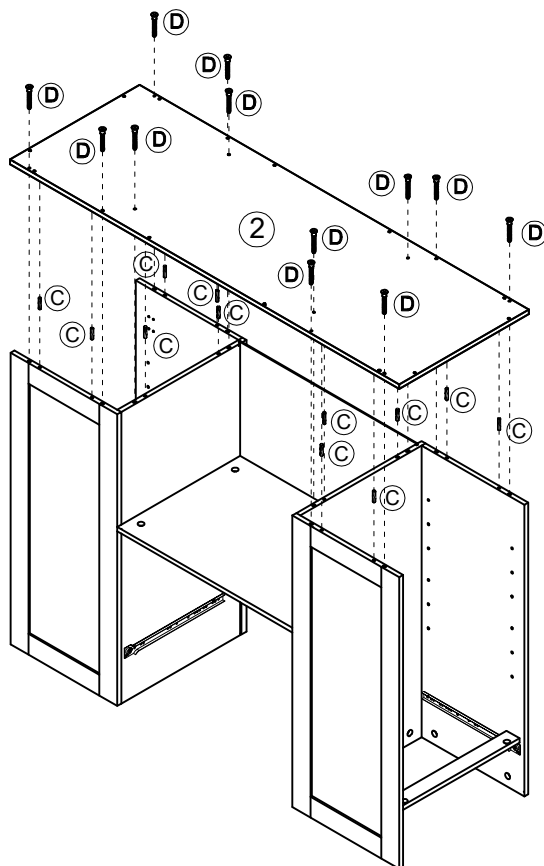

STEP 10 / ÉTAPE 10:



C	X12	D	X12
			
Ø6*30mm		Ø5*40mm	

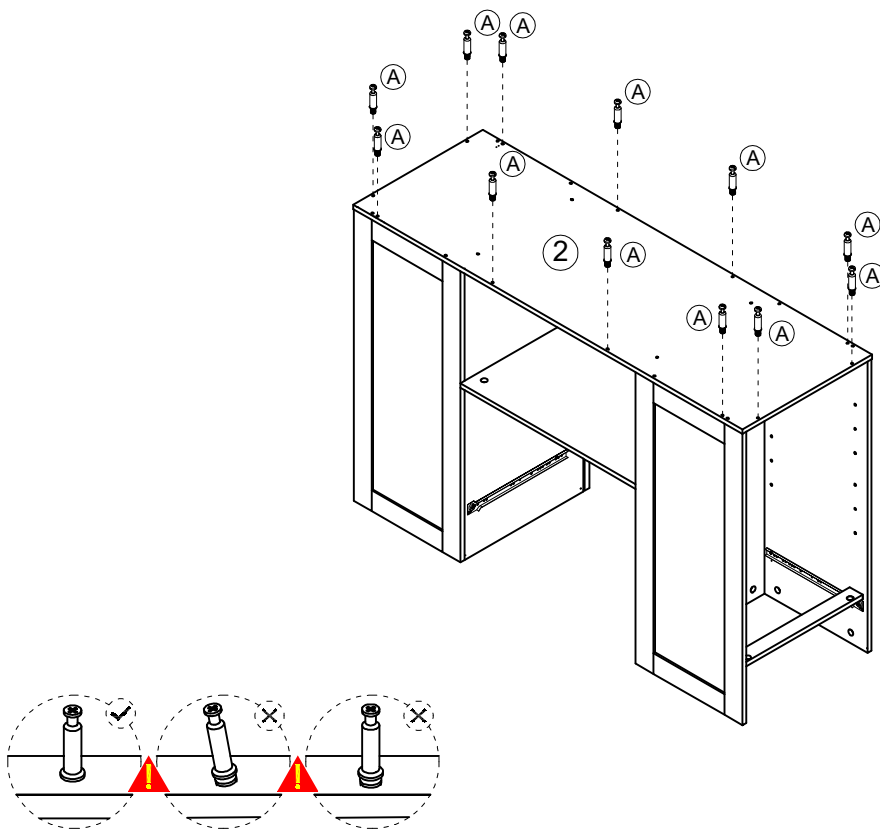

STEP 11 / ÉTAPE 11:

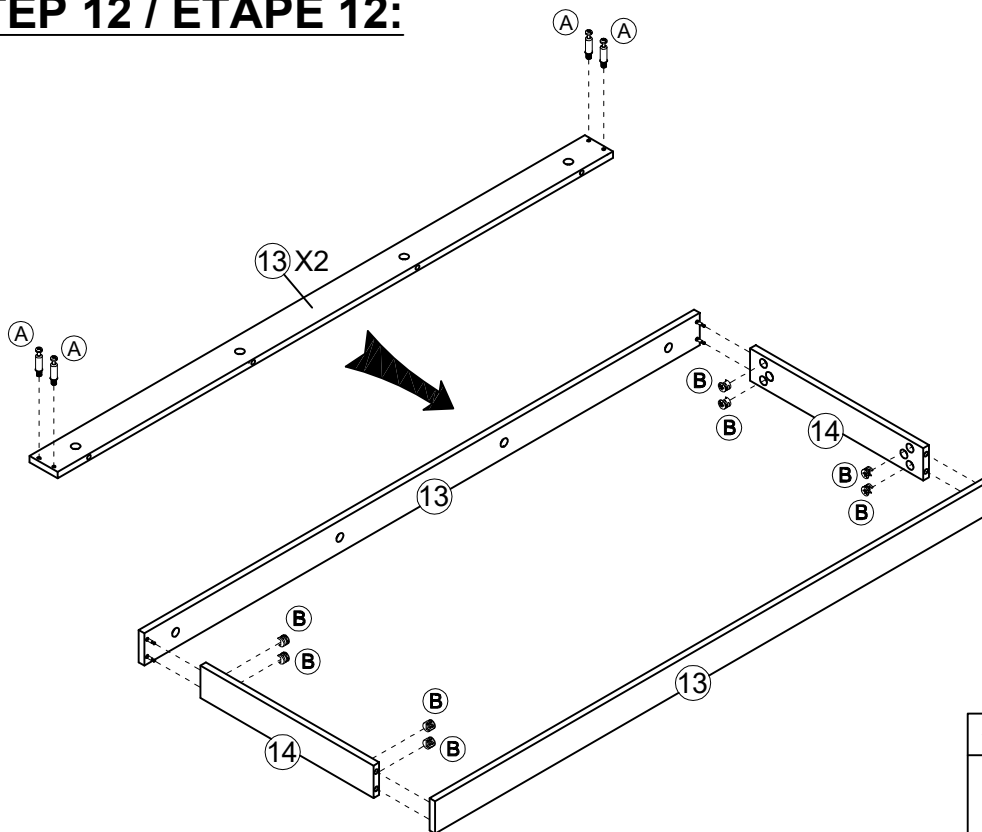

(A)	X12
	
Ø6*35mm	

STEP 12 / ÉTAPE 12:



(B)	X8	(A)	X8
			
Ø15*9.5mm		Ø6*35mm	

STEP 13 / ÉTAPE 13:

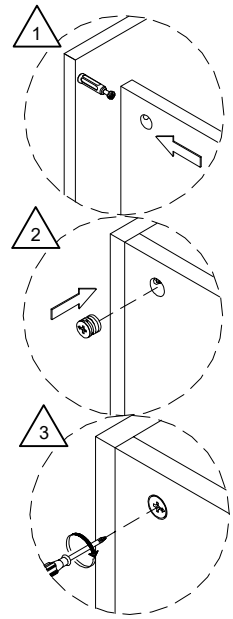
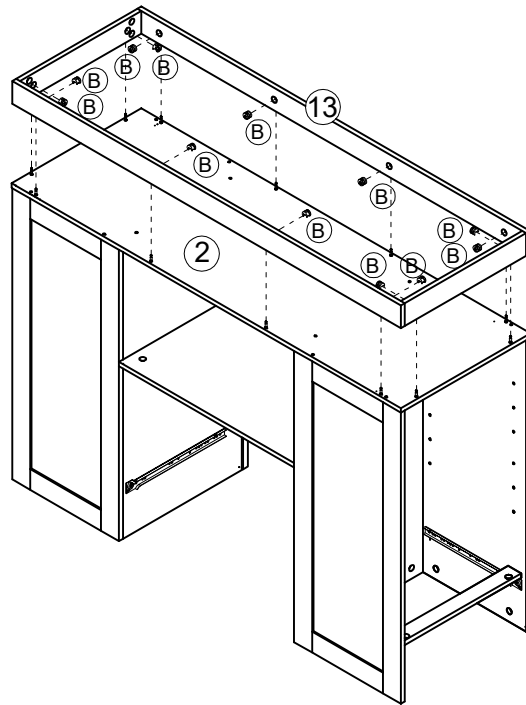

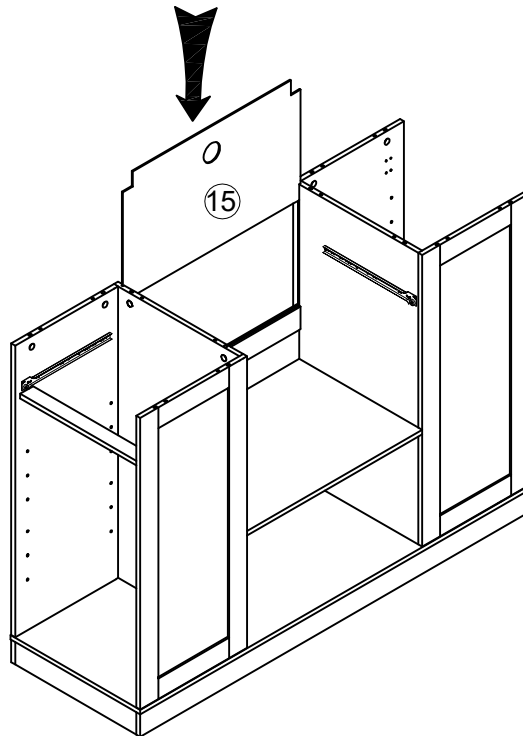

(B)	X12
Ø15*9.5mm	

STEP 14 / ÉTAPE 14:



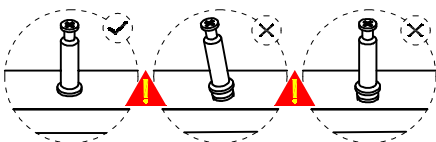
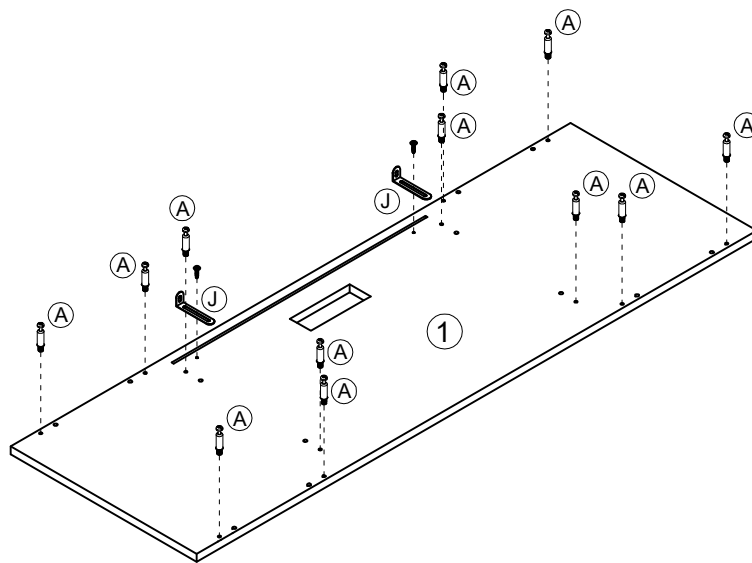

STEP 15 / ÉTAPE 15:

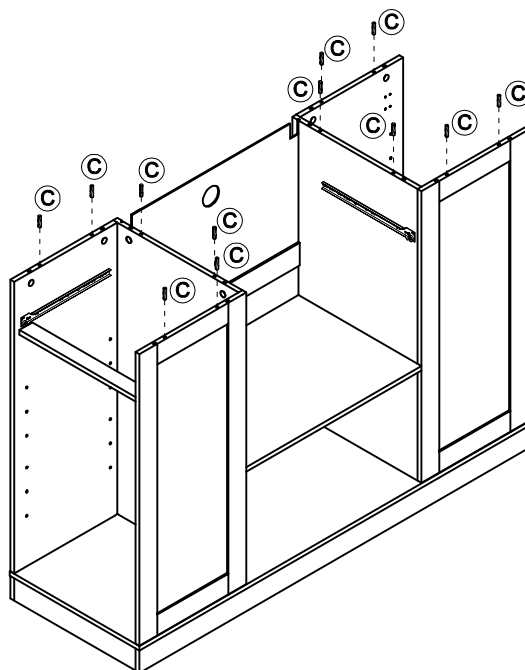

(J)	X2	(A)	X12
			
Ø4*12mm		Ø6*35mm	

STEP 16 / ÉTAPE 16:



(C)	X12
	
Ø6*30mm	

STEP 17 / ÉTAPE 17:

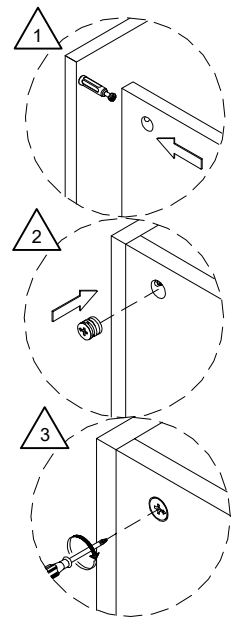
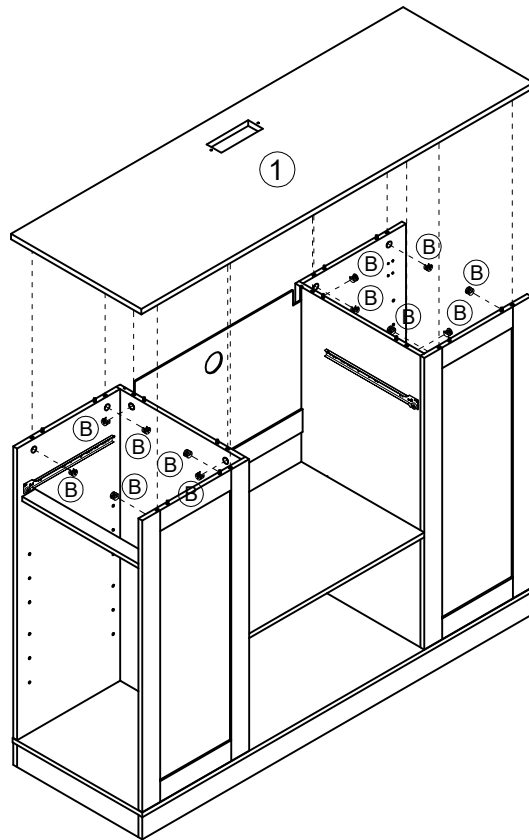

(B)	X12
Ø15*9.5mm	

STEP 18 / ÉTAPE 18:

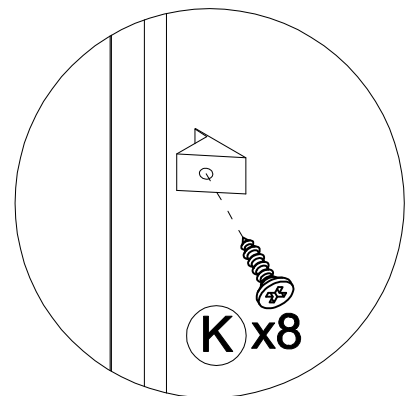
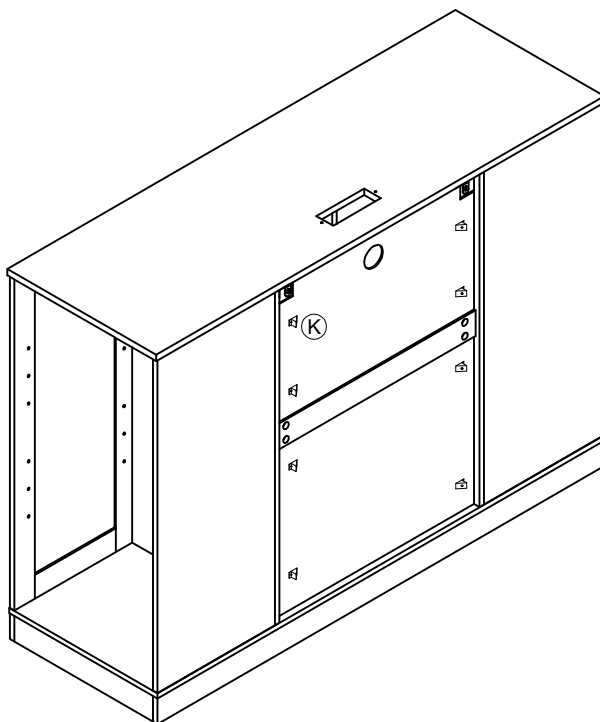

(K)	X8
Ø3*16mm	

STEP 19 / ÉTAPE 19:

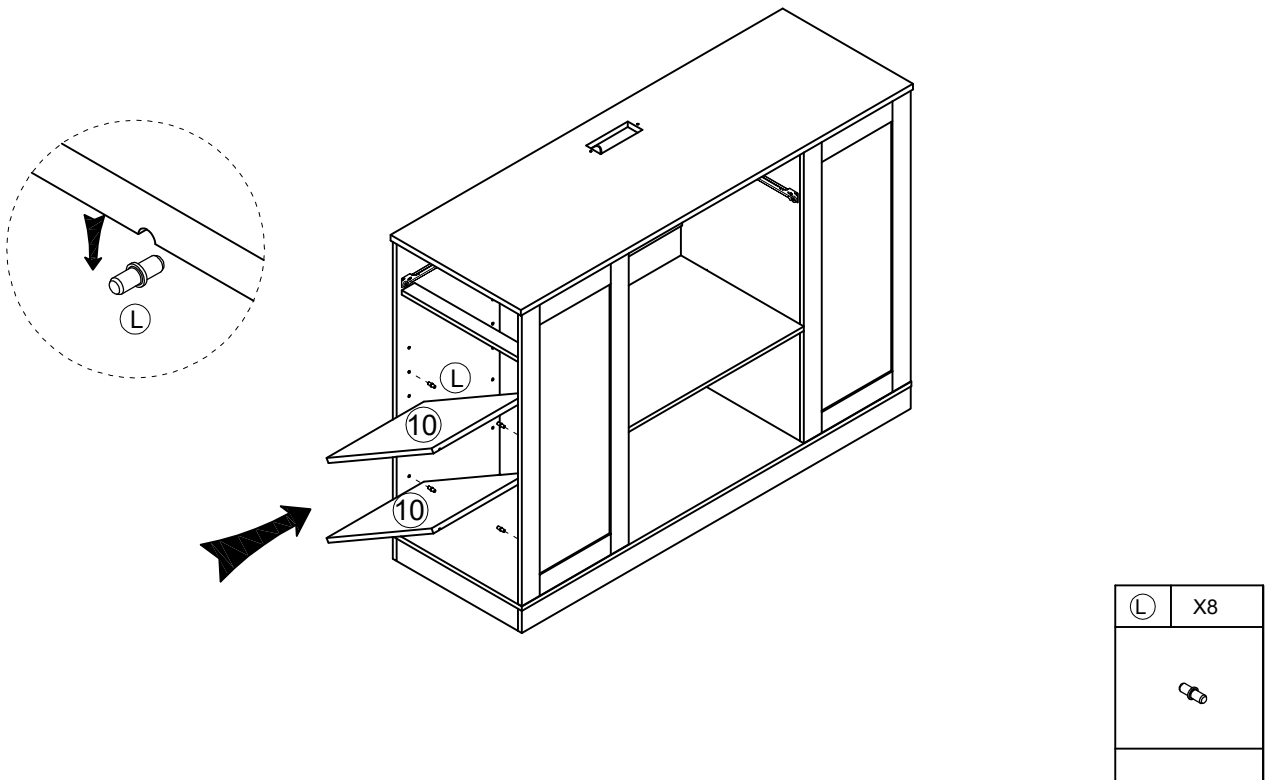

STEP 20 / ÉTAPE 20:

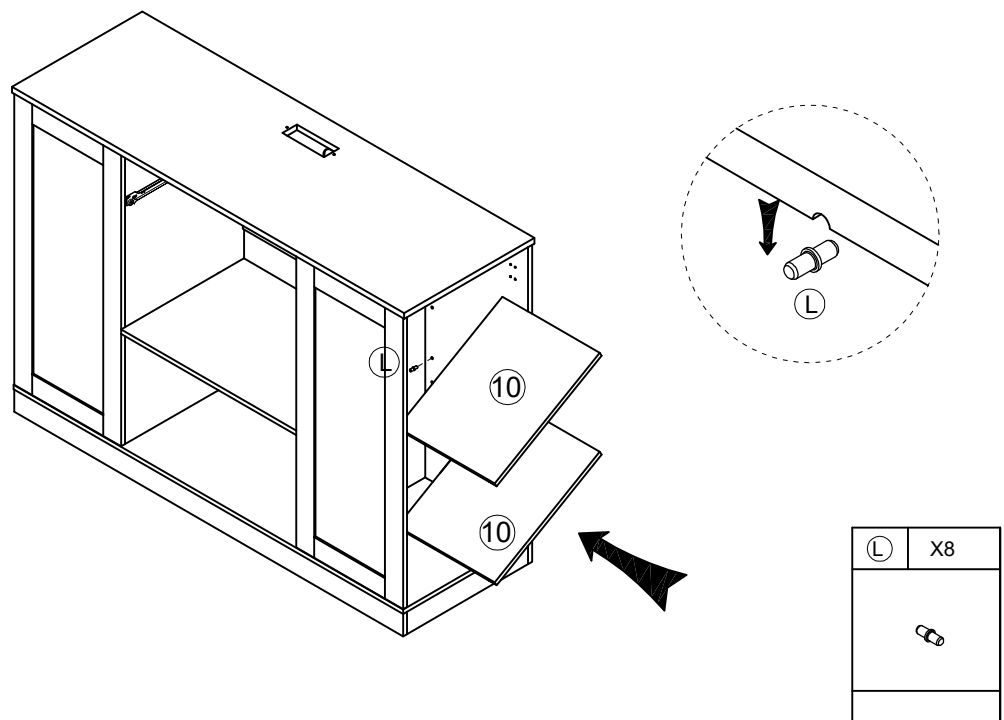

STEP 21 / ÉTAPE 21:

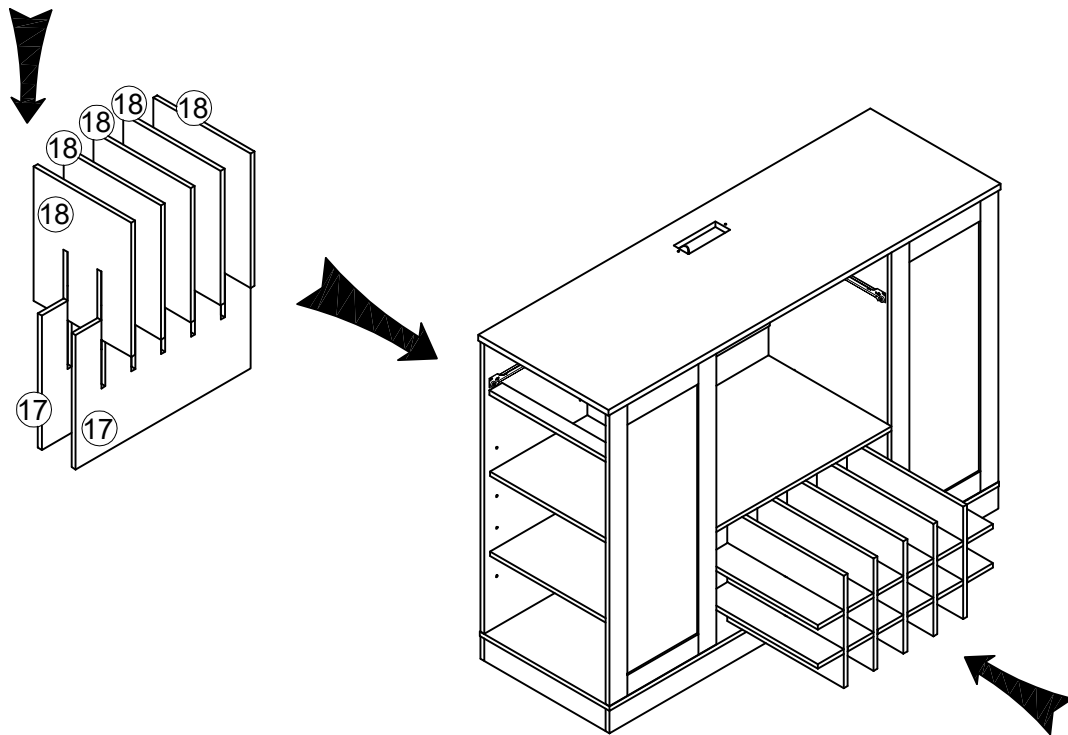

STEP 22 / ÉTAPE 22:

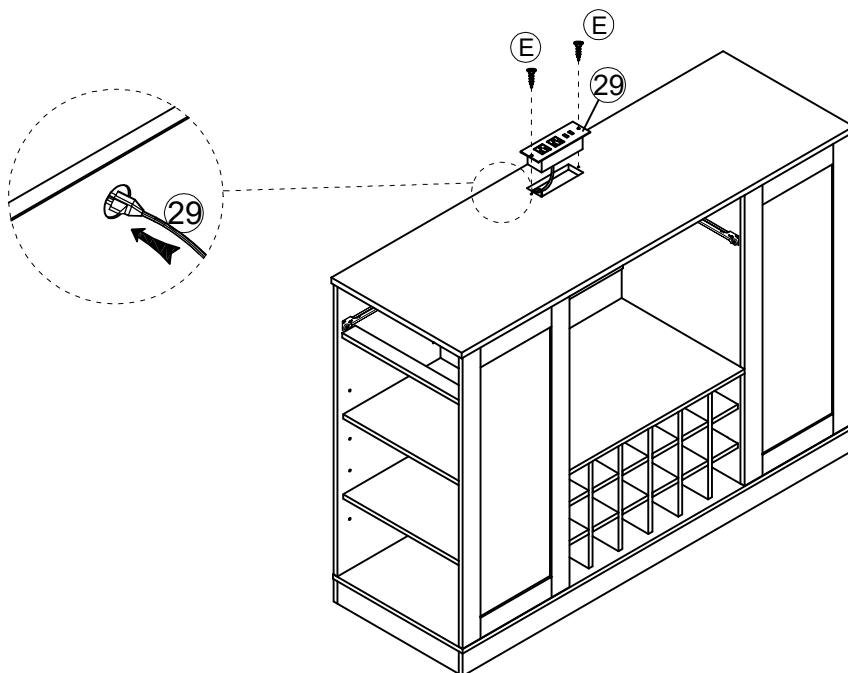

Ⓔ	X2
	
Ø3.5*12mm	

STEP 23 / ÉTAPE 23:

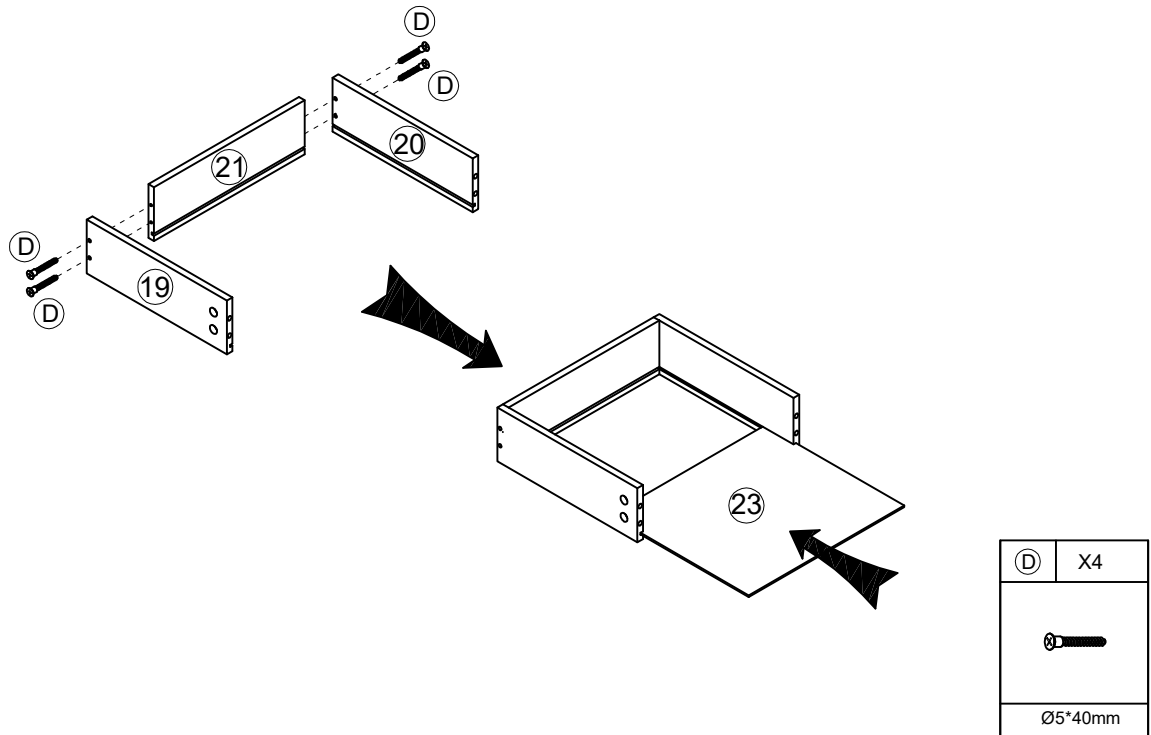

STEP 24 / ÉTAPE 24:

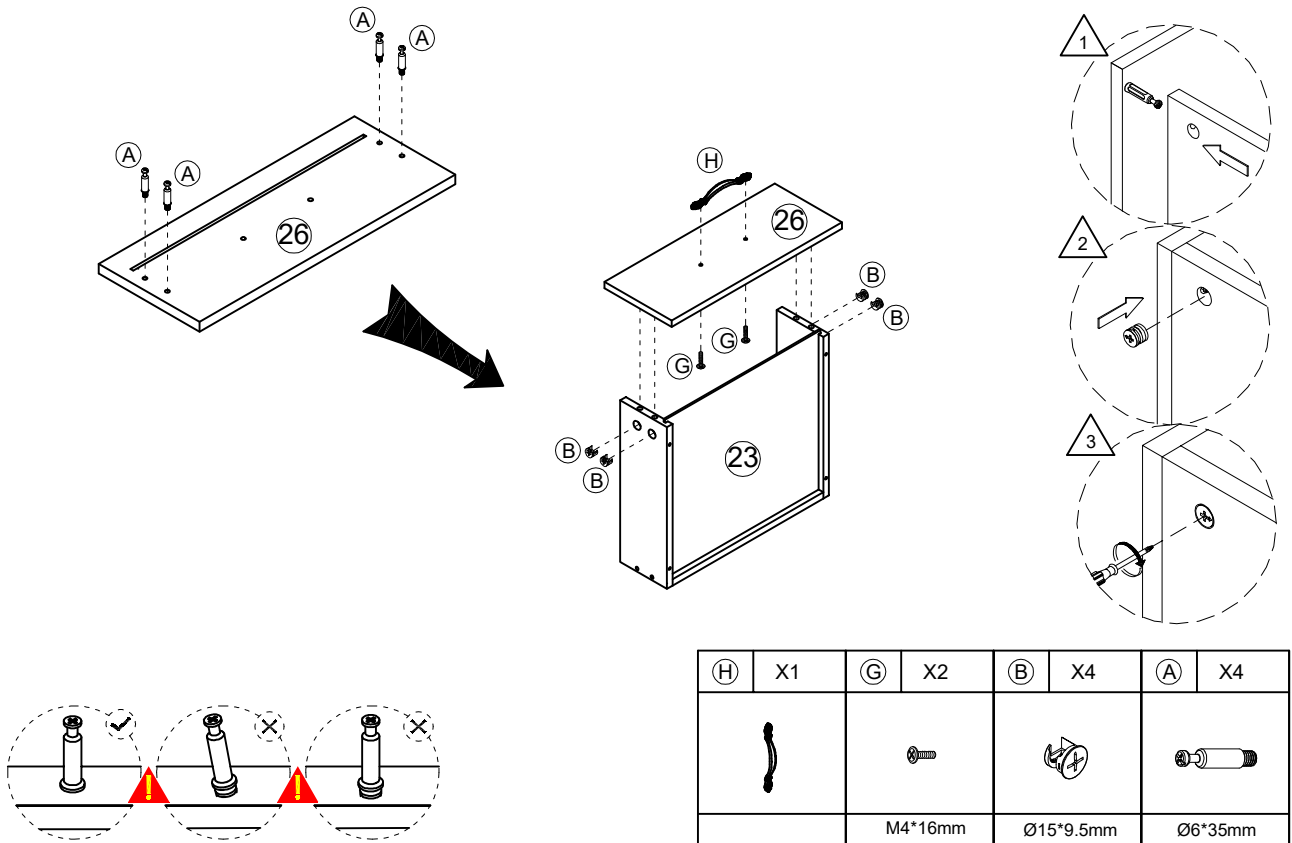

STEP 25 / ÉTAPE 25:

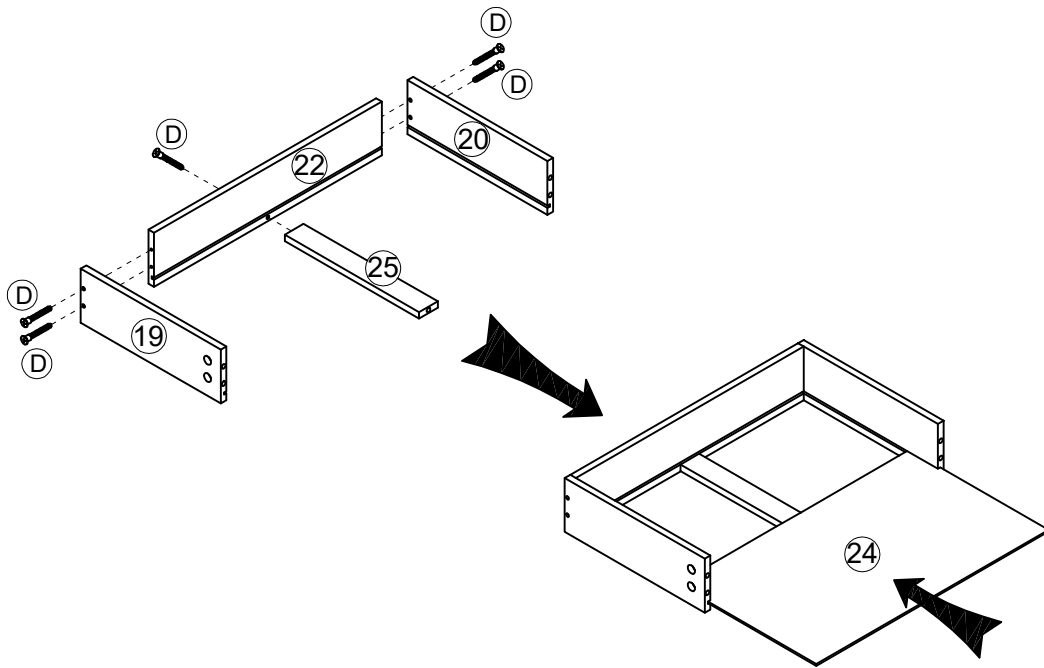

(D)	X5
Ø5*40mm	

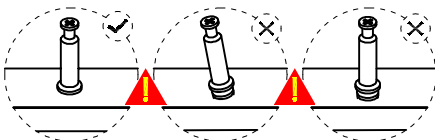
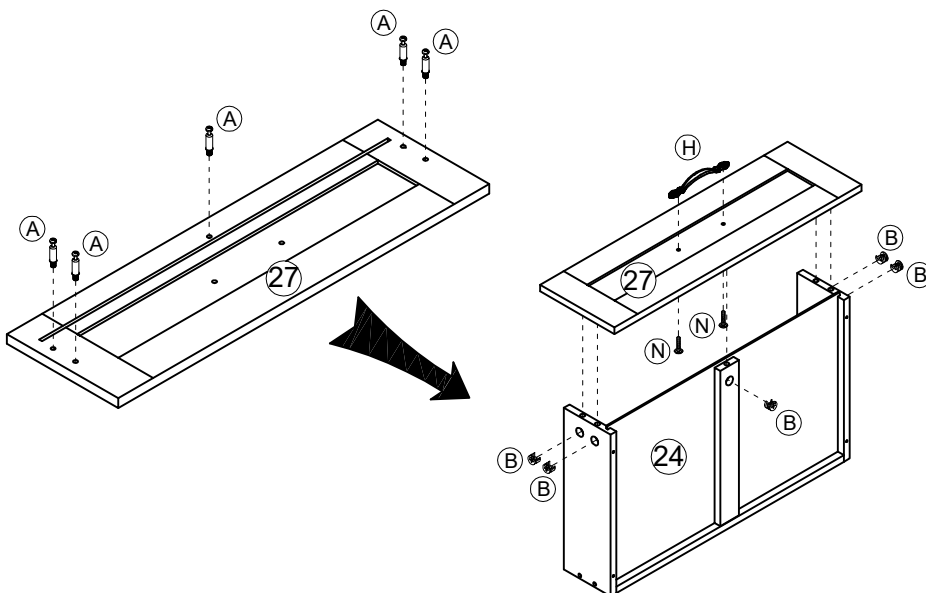

STEP 26 / ÉTAPE 26:

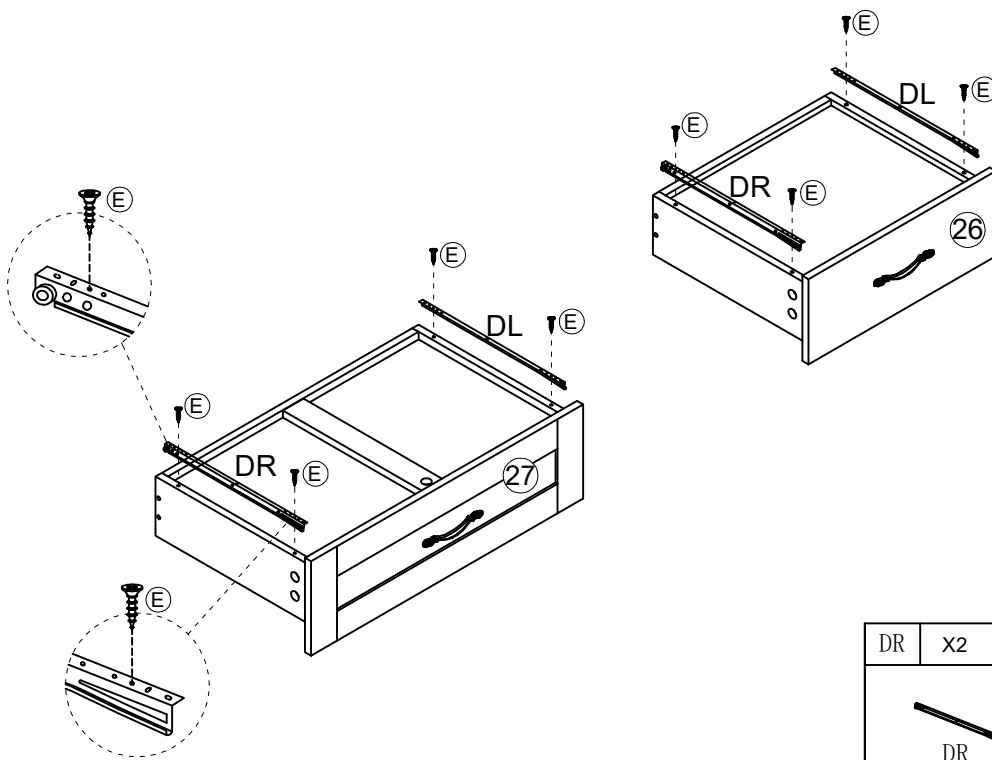

(H)	X1	(N)	X2	(B)	X5	(A)	X5
		M4*8mm		Ø15*9.5mm		Ø6*35mm	

STEP 27 / ÉTAPE 27:





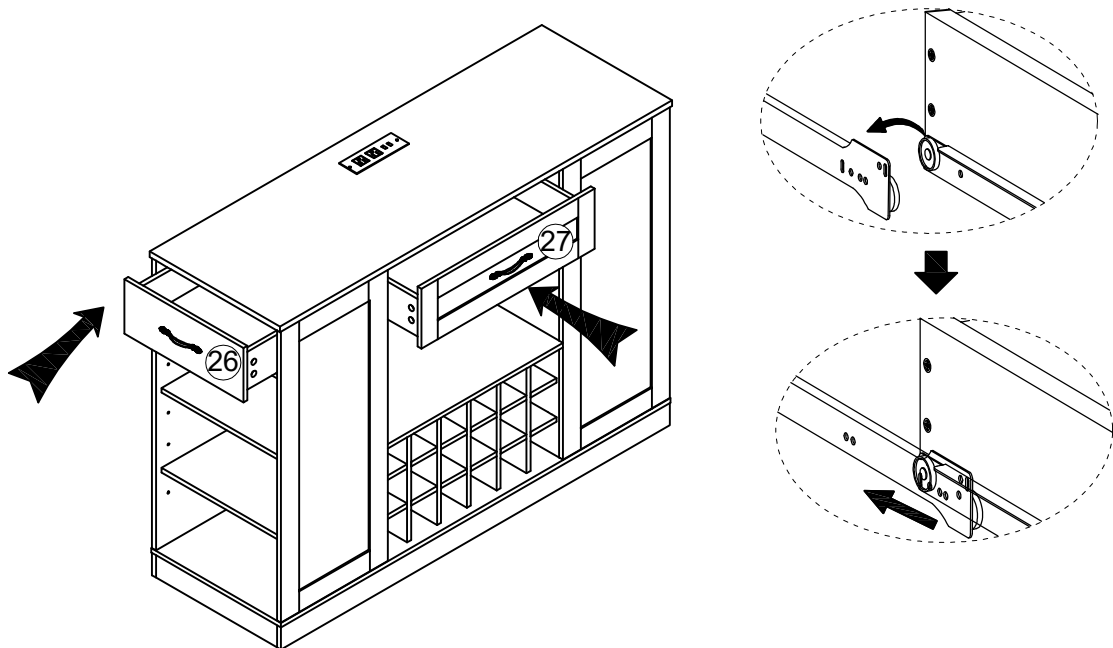

DR	X2	DL	X2	(E)	X8
					
300mm		300mm		Ø3.5*12mm	

STEP 28 / ÉTAPE 28:

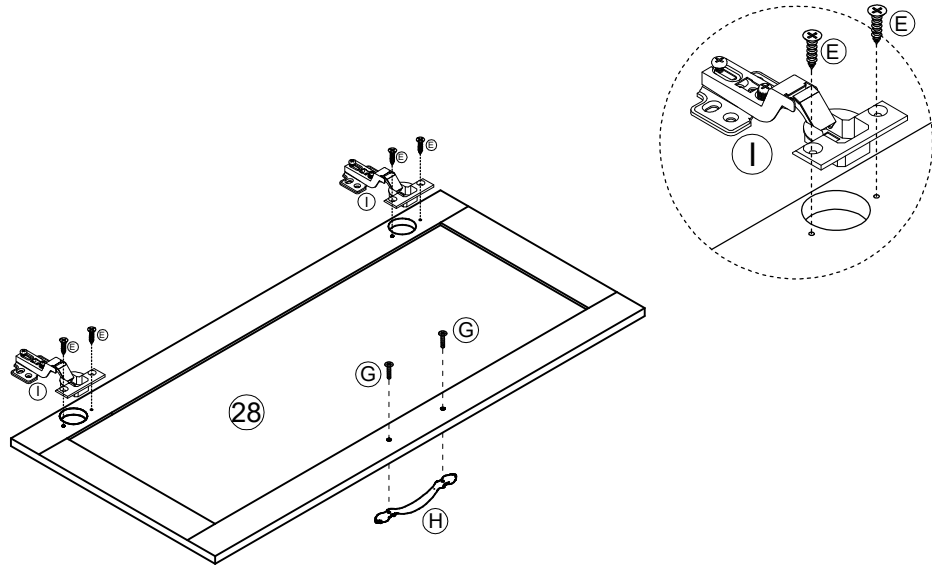

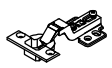

STEP 29 / ÉTAPE 29:

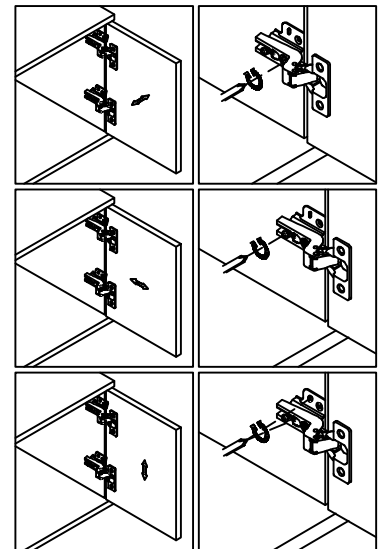
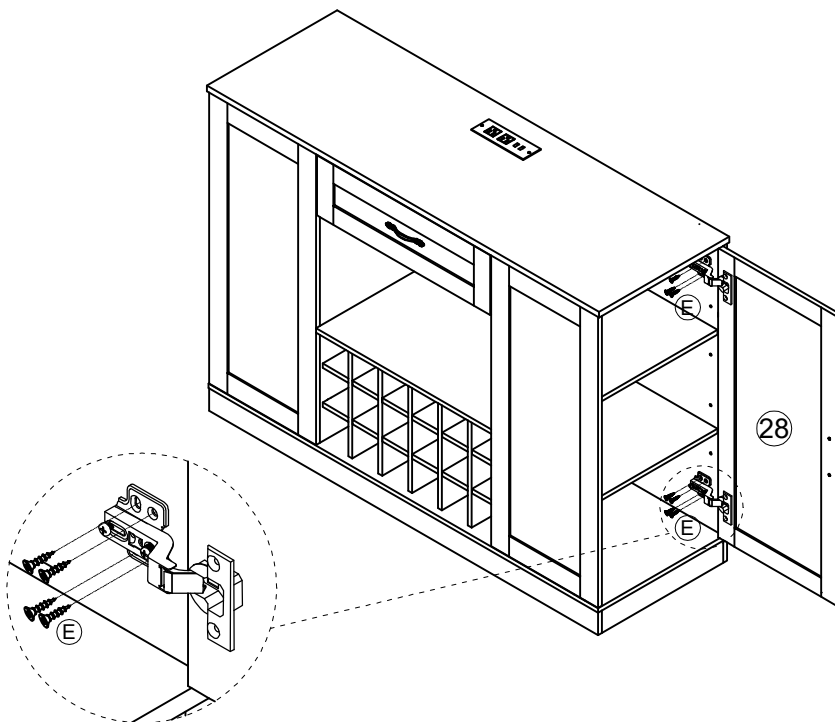

(G)	X2	(H)	X1	(I)	X2	(E)	X4
							
M4*16mm						Ø3.5*12mm	

STEP 30 / ÉTAPE 30:



(E)	X8
	
Ø3.5*12mm	

STEP 31 / ÉTAPE 31:

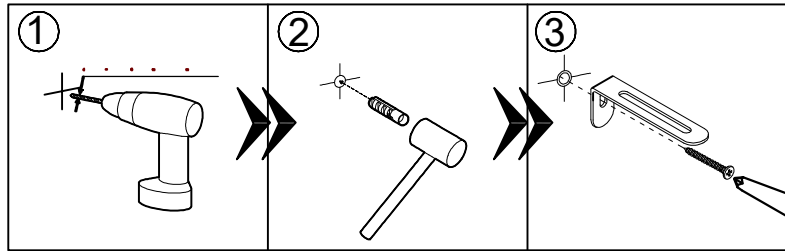

Pull out drawer 27 and install J

Tirez le tiroir 27 et installez J

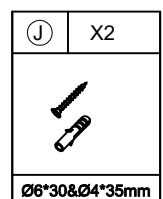
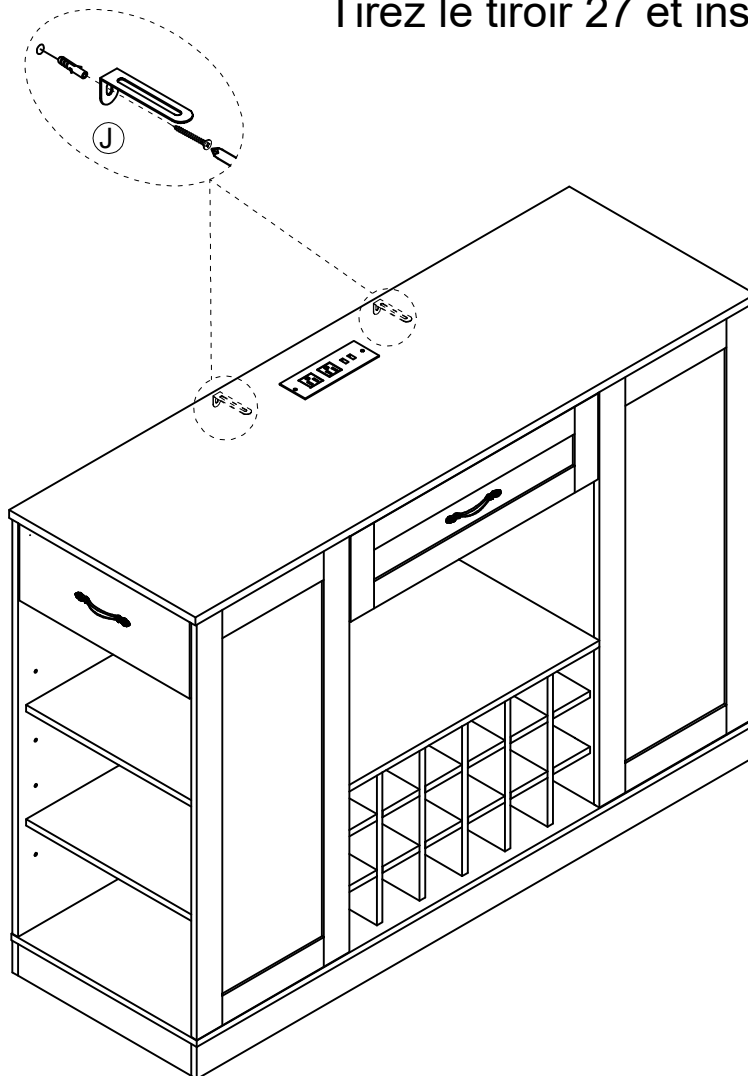

COMPLETE / COMPLÈTE:

