

# ASSEMBLY INSTRUCTIONS INSTRUCTIONS DE MONTAGE

## BAR TABLE TABLE DE BAR

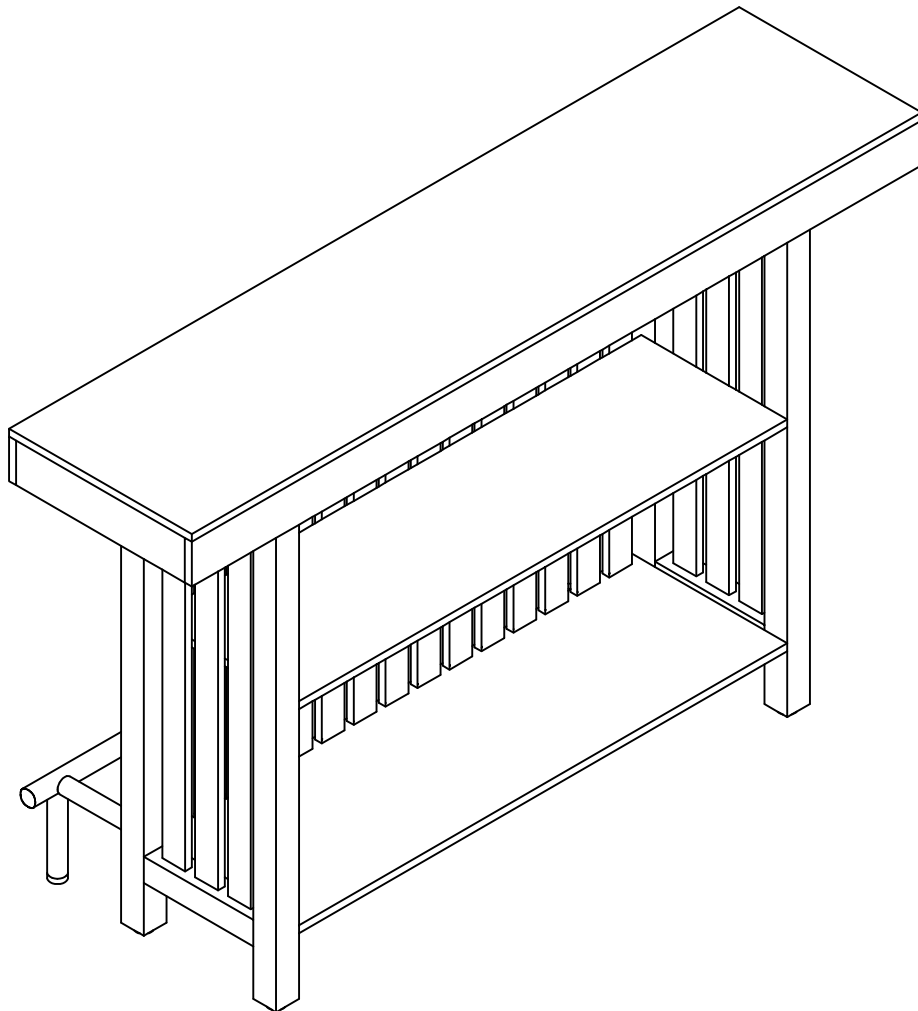

**N889P427904**

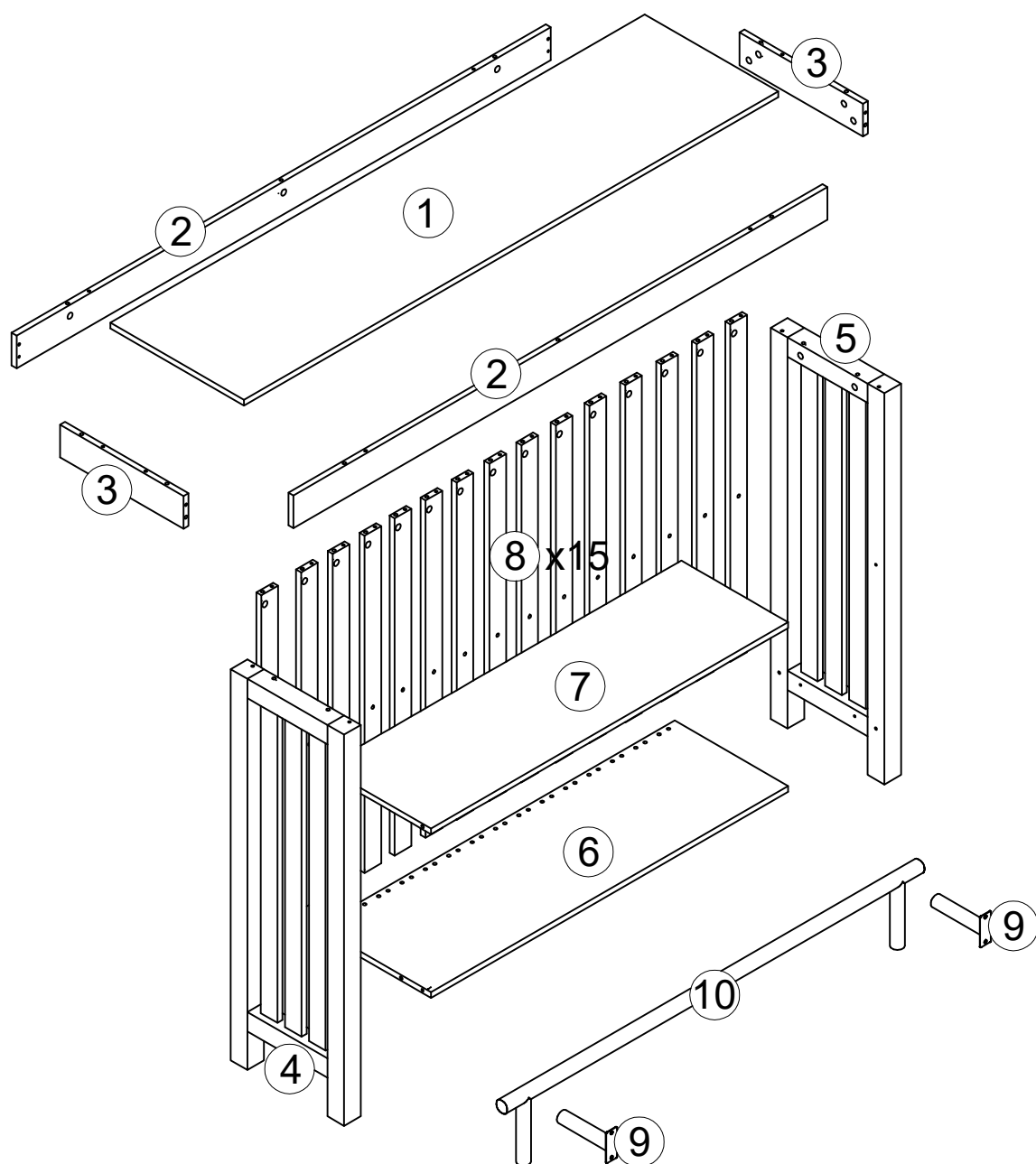

WARNING		AVERTISSEMENT	
	This product is NOT a Clothing Storage Unit (CSU). DO NOT use it for clothing storage. Improper use may cause furniture tipover.		Ce produit N'EST PAS une unité de rangement pour vêtements (CSU). NE l'utilisez PAS pour le rangement de vêtements. Une utilisation impropre peut entraîner un basculement des meubles.

# Detail View / Vue détaillée





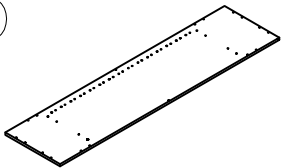
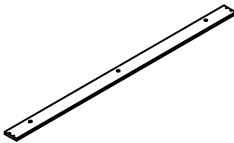
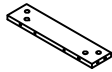
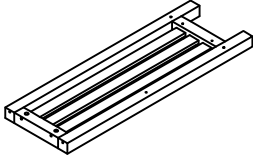
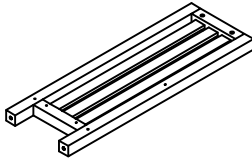
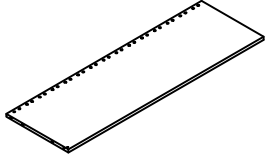
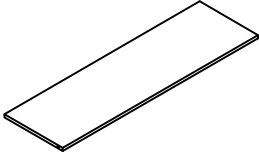
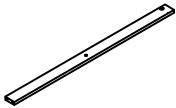

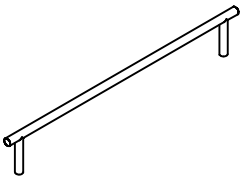

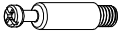

**Part List / Liste des pieces**

**N889P427904**

<p>①</p> 	<p>②</p> 	<p>③</p> 
<p>Top Panel (1 pcs) Panneau superieur (1 pièces)</p>	<p>Long Side Baffle (2 pcs) Baffle long côté (2 pièces)</p>	<p>Short Side Baffle (2 pcs) Baffle à côté court (2 pièces)</p>
<p>④</p>  <p>L</p>	<p>⑤</p>  <p>R</p>	<p>⑥</p> 
<p>Left Side Panel (1 pcs) Panneau latéral gauche (1 pièces)</p>	<p>Right Side Panel (1 pcs) Panneau latéral droit (1 pièces)</p>	<p>Bottom Panel (1 pcs) Panneau inferieur (1 pièces)</p>
<p>⑦</p> 	<p>⑧</p> 	<p>⑨</p> 
<p>Center Panel (1 pcs) Panneau central (1 pièces)</p>	<p>Back Panel (15 pcs) Panneau arriere (15 pièces)</p>	<p>Decorative Iron Parts (2 pcs) Pièces décoratives en fer (2 pièces)</p>
<p>⑩</p> 		
<p>Decorative Iron Feet (2 pcs) Pied de fer décoratif (2 pièces)</p>		

## Hardware List / Liste du matériel

# N889P427904

<p><b>A</b></p>  <p>Ø6*35mm</p>	<p><b>B</b></p>  <p>Ø15*9.5mm</p>	<p><b>C</b></p>  <p>Ø6*30mm</p>	<p><b>D</b></p>  <p>M6*50mm</p>	<p><b>E</b></p>  <p>M6*12mm</p>	<p><b>F</b></p>  <p>ST7*40mm</p>
<p>Cam Bolt (39 pcs) Boulon a came (39 pièces)</p>	<p>Cam Nut (39 pcs) Ecrou a came (39 pièces)</p>	<p>Wood Dowel (35 pcs) Cheville en bois (35 pièces)</p>	<p>Bolt (2 pcs) Boulon (2 pièces)</p>	<p>Bolt (4 pcs) Boulon (4 pièces)</p>	<p>Bolt (45 pcs) Boulon (45 pièces)</p>
<p><b>G</b></p> 	<p><b>H</b></p>  <p>S4</p>				
<p>Leveling Foot (6 pcs) Réguler les pieds (6 pièces)</p>	<p>Allen Wrench (1 pcs) Clé Allen (1 pièces)</p>				

**ASSEMBLY TOOLS REQUIRED ( NOT INCLUDED )  
OUTILS D'ASSEMBLAGE REQUIS (NON INCLUS)**



**PLEASE BE CAREFUL DO NOT DAMAGE THE HOLE  
POSITION WHEN YOU USE POWER TOOLS !**

**FAITES ATTENTION À NE PAS ENDOMMAGER LA  
POSITION DE MAINTIEN LORSQUE VOUS UTILISEZ DES  
OUTILS ÉLECTRIQUES !**

## STEP 1 / ÉTAPE 1:

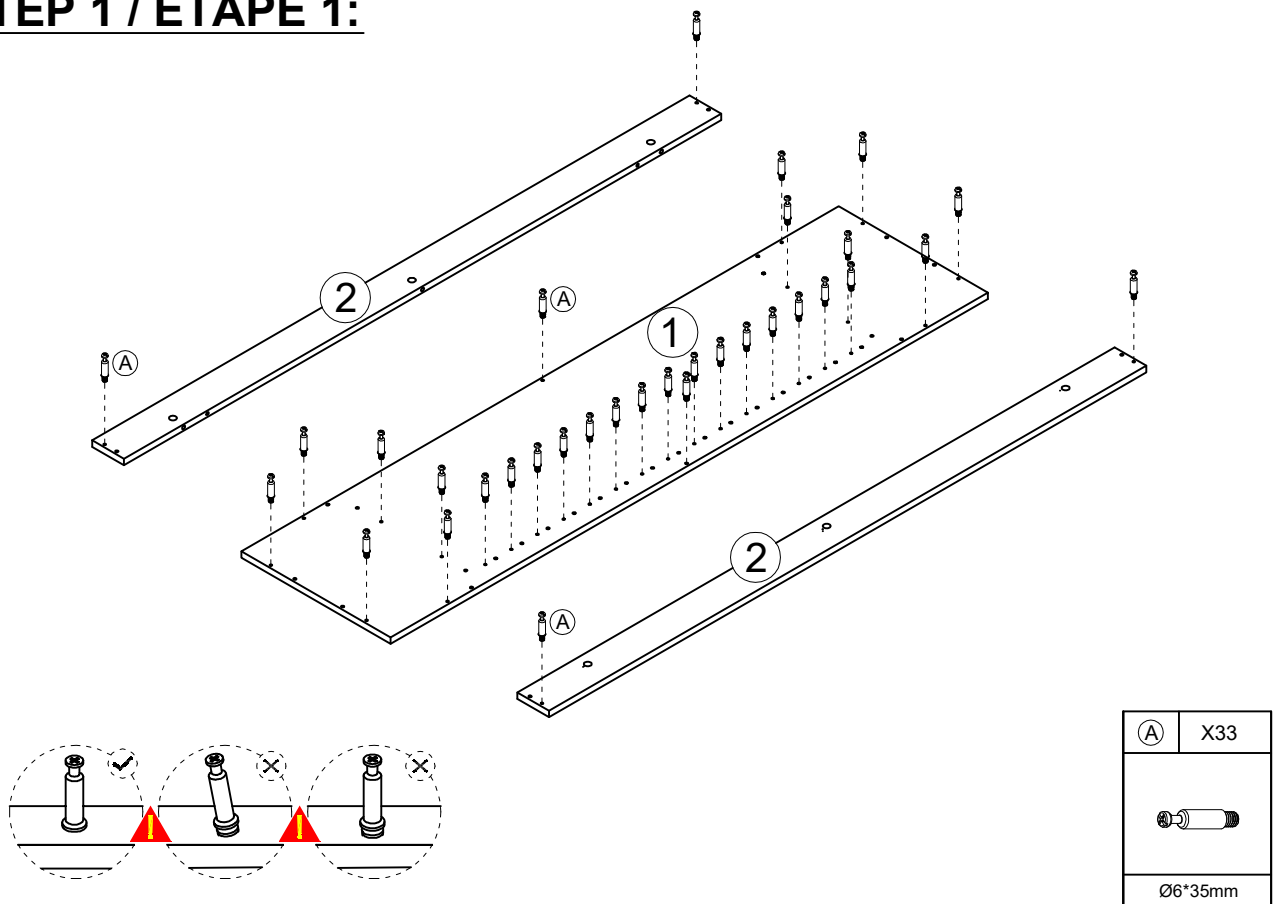

## STEP 2 / ÉTAPE 2:

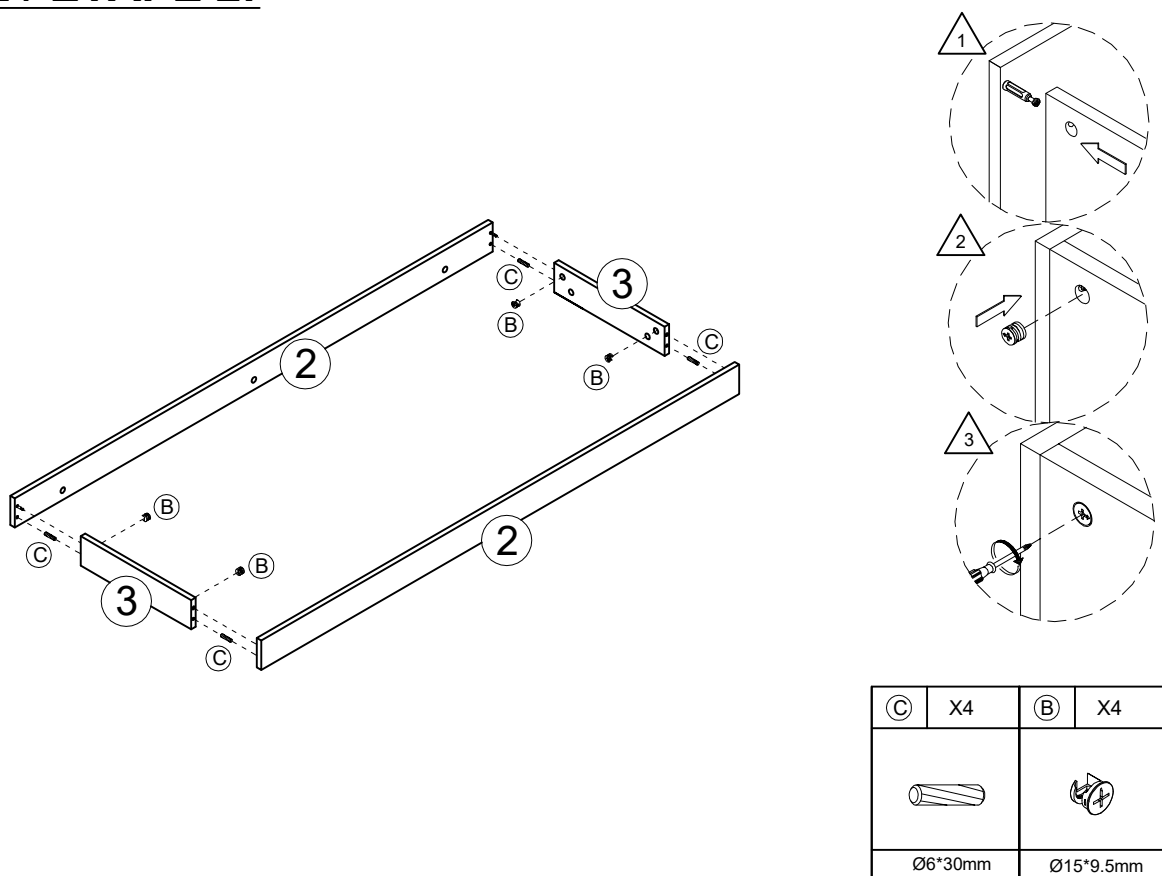

### STEP 3 / ÉTAPE 3:

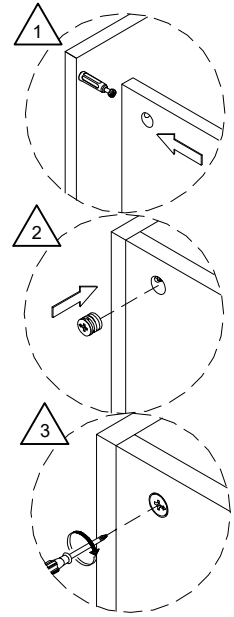
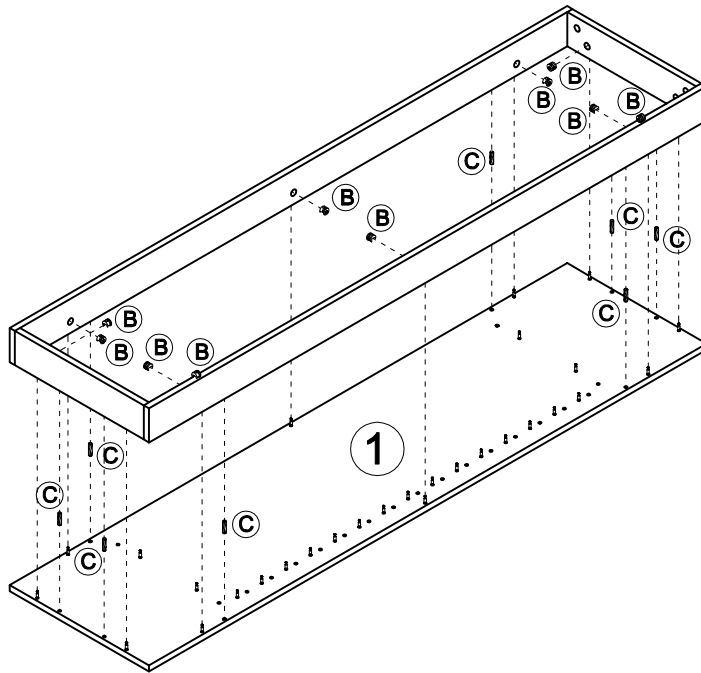

(C)	X8	(B)	X10
Ø6*30mm		Ø15*9.5mm	

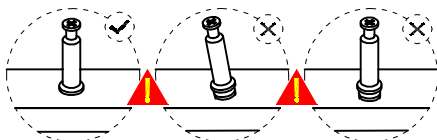
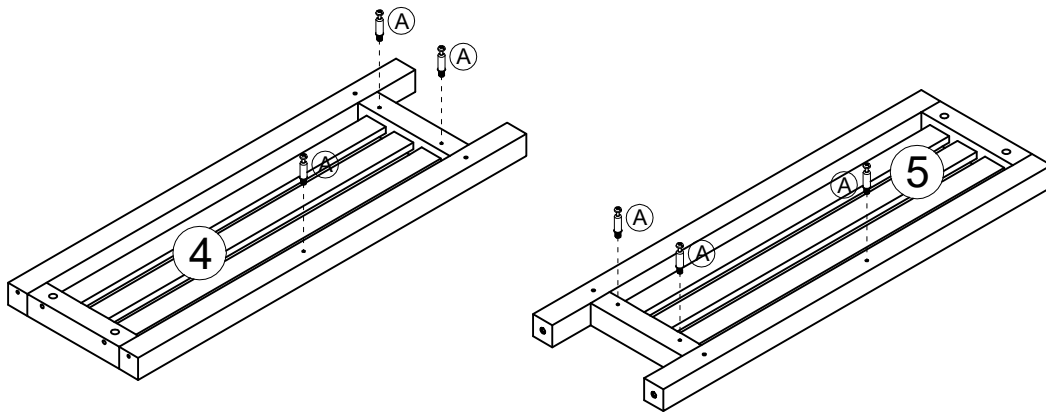

### STEP 4 / ÉTAPE 4:

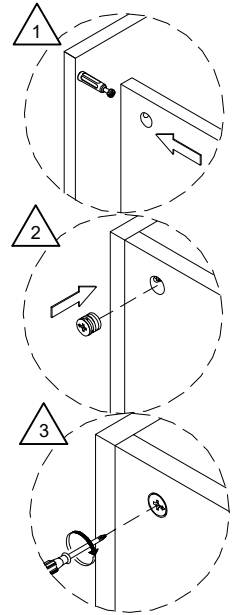
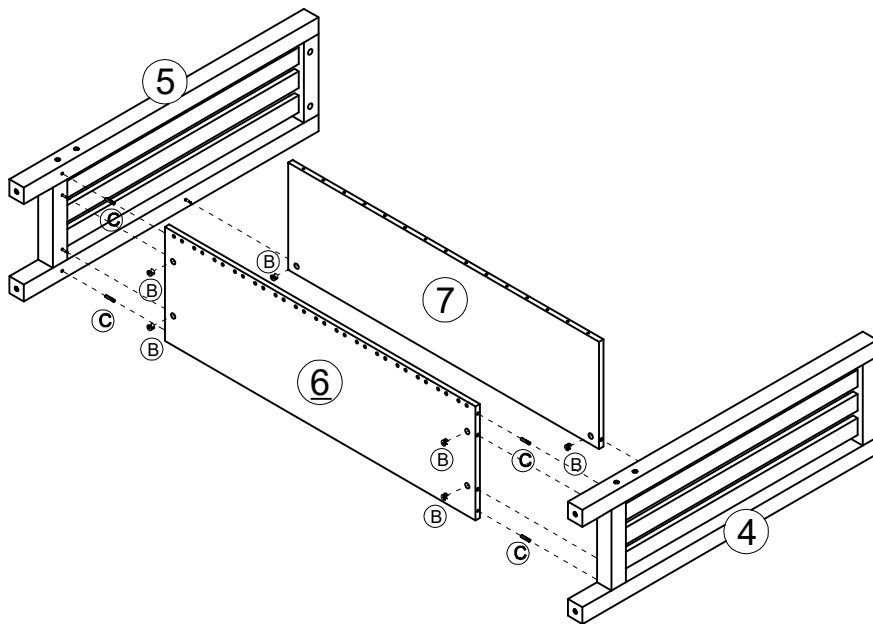

(A)	X6
Ø6*35mm	

## STEP 5 / ÉTAPE 5:



C	X8	B	X10
			
Ø6*30mm		Ø15*9.5mm	

## STEP 6 / ÉTAPE 6:

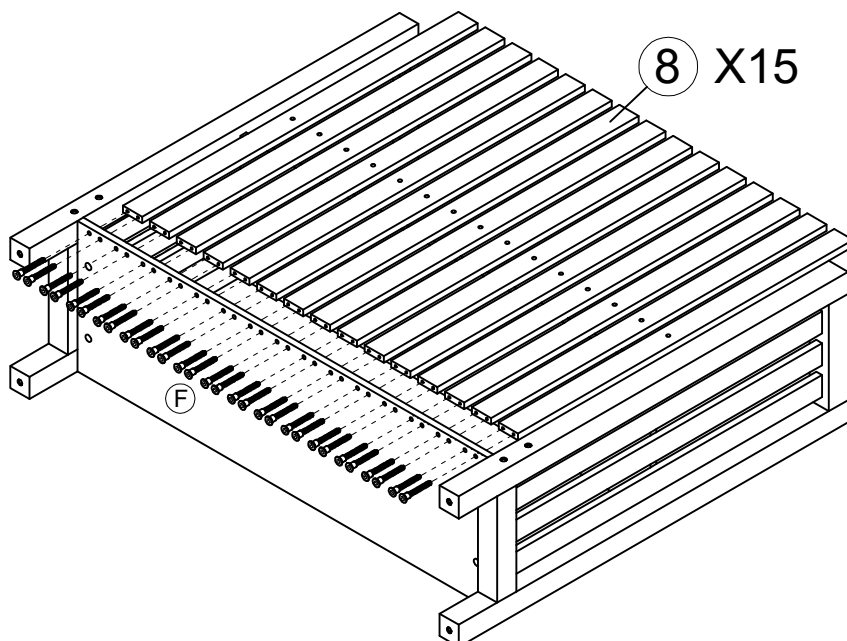

F	X30
	
ST7*40mm	

## STEP 7 / ÉTAPE 7:

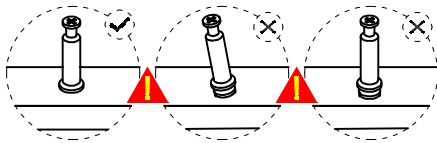
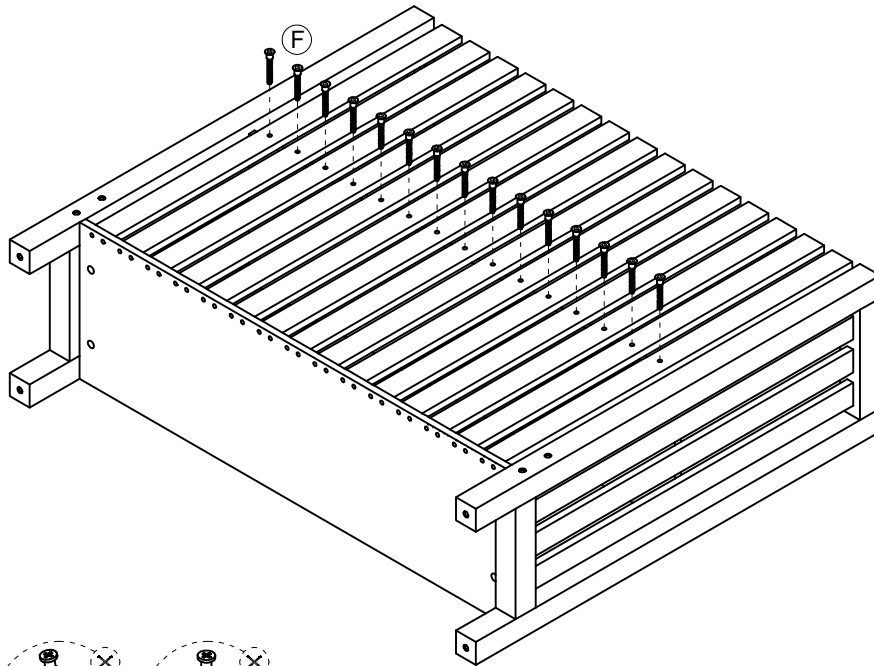

F	X15
	
ST7*40mm	

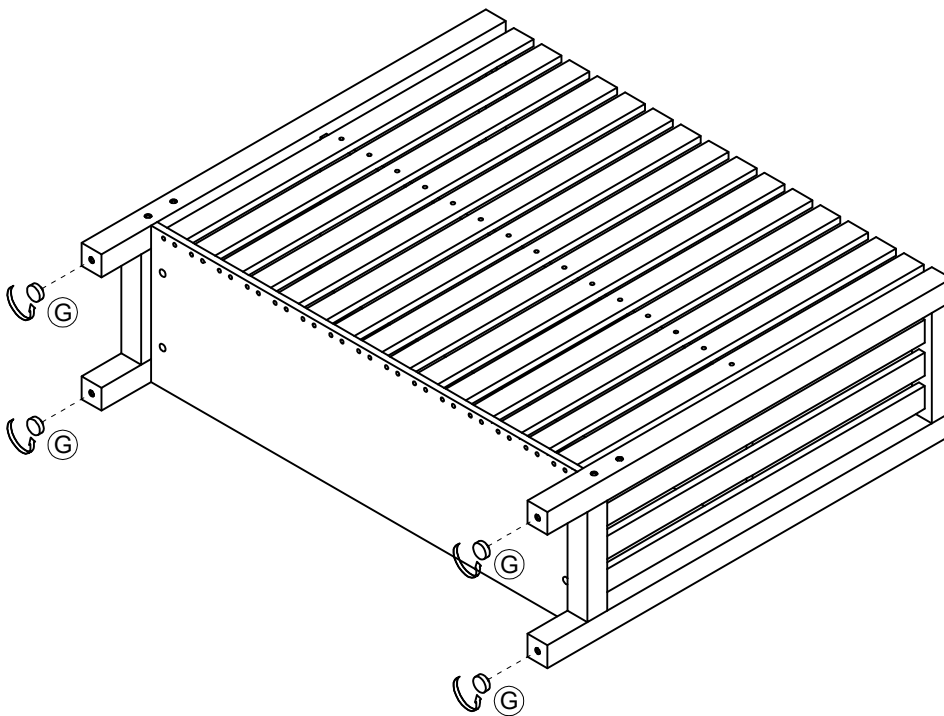

## STEP 8 / ÉTAPE 8:

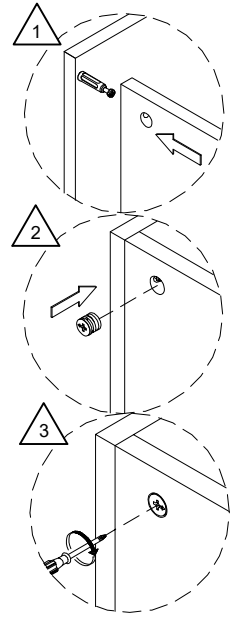
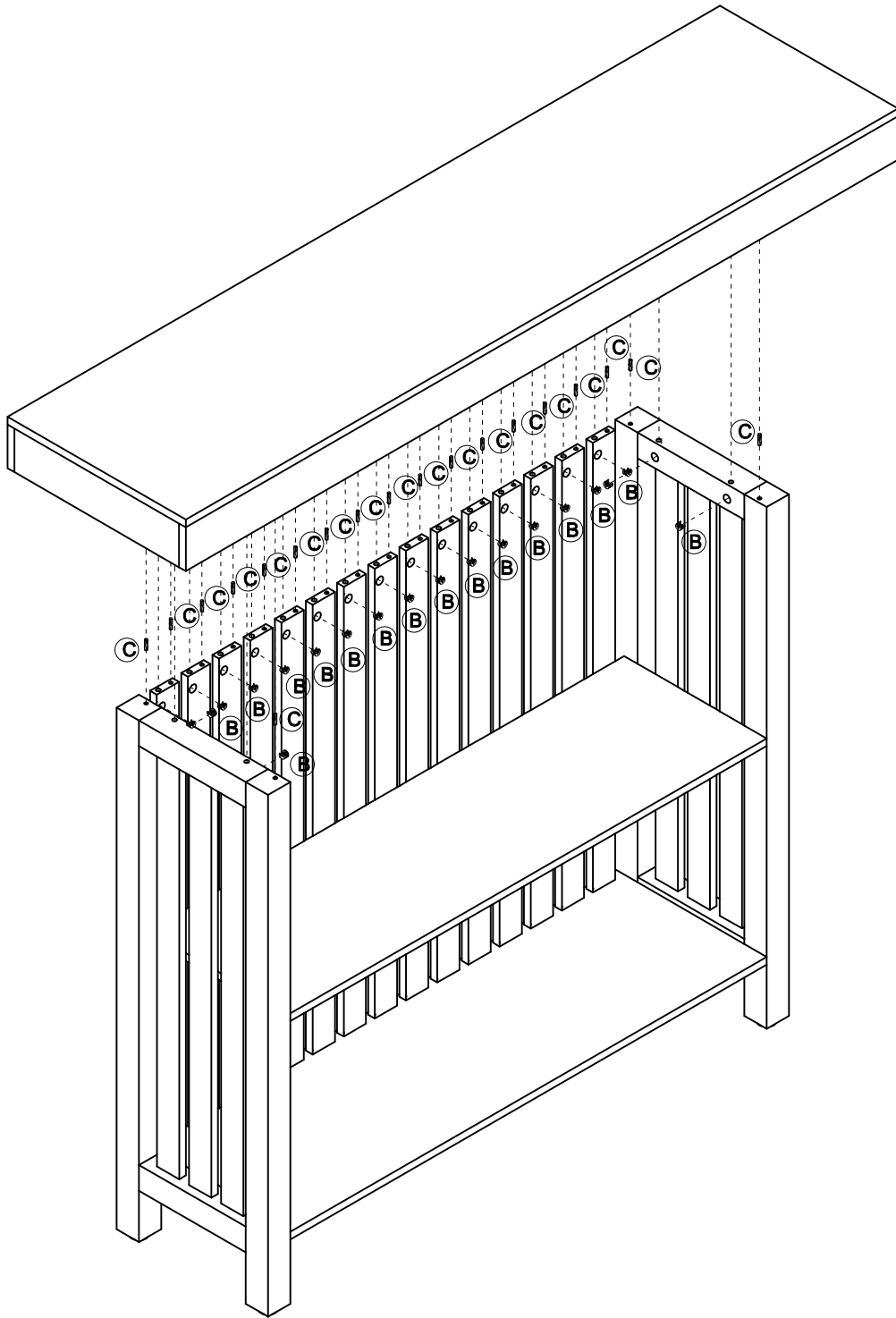

G	X4
	

# STEP 9 / ÉTAPE 9:



C	X19	B	X19
			
Ø6*30mm		Ø15*9.5mm	

## STEP 10 / ÉTAPE 10:

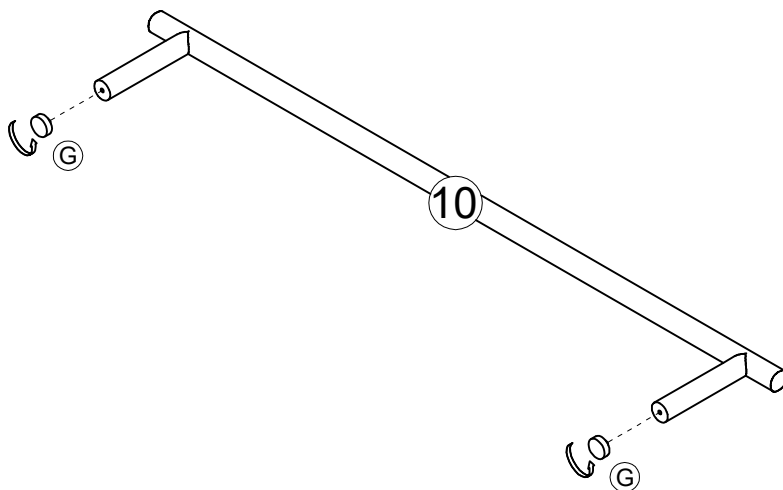

G	X2

## STEP 11 / ÉTAPE 11:

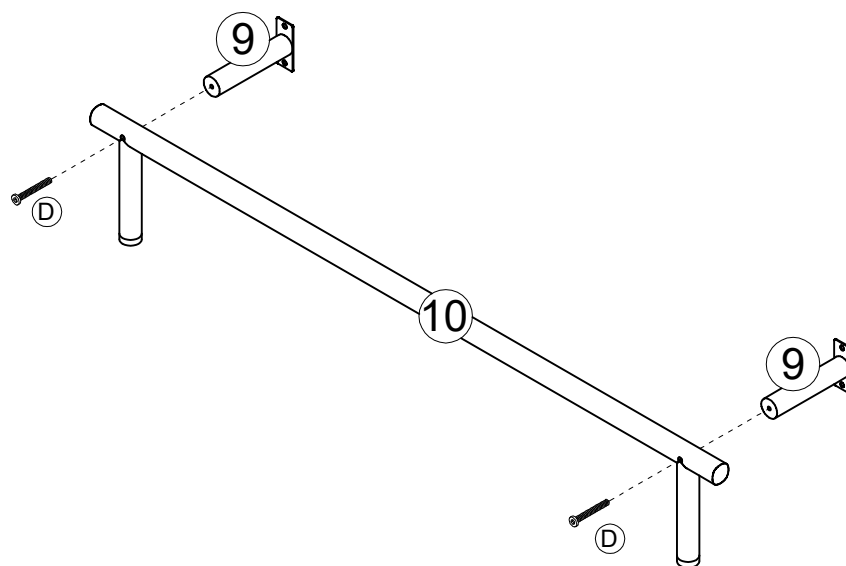
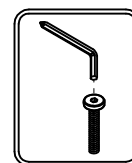

H	X1	D	X2
S4		M6*50mm	

# STEP 12 / ÉTAPE 12:

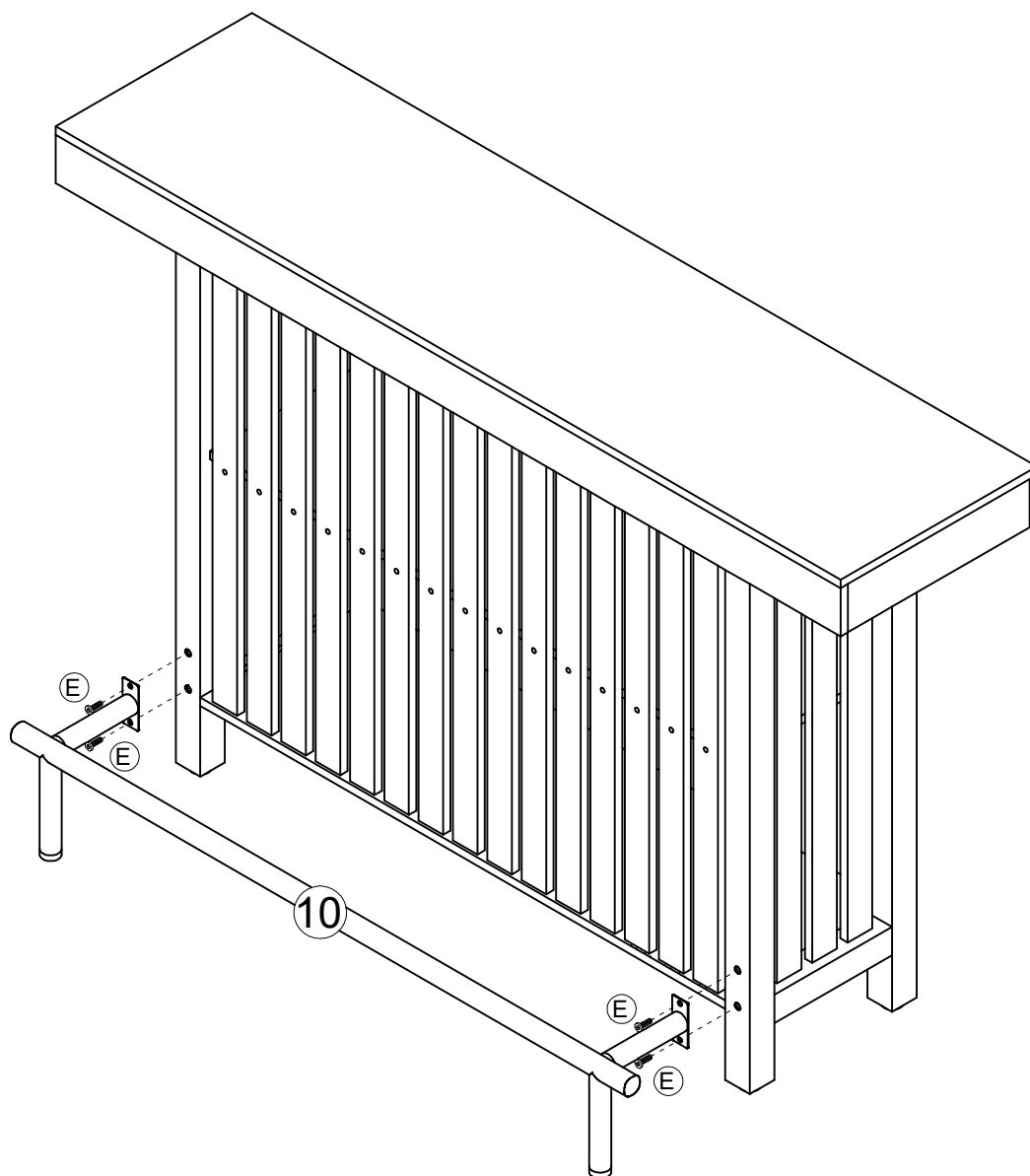
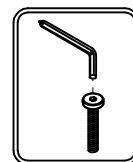

Ⓔ	X4
M6*12mm	

**COMPLETE / COMPLÈTE:**

