

N892P433765

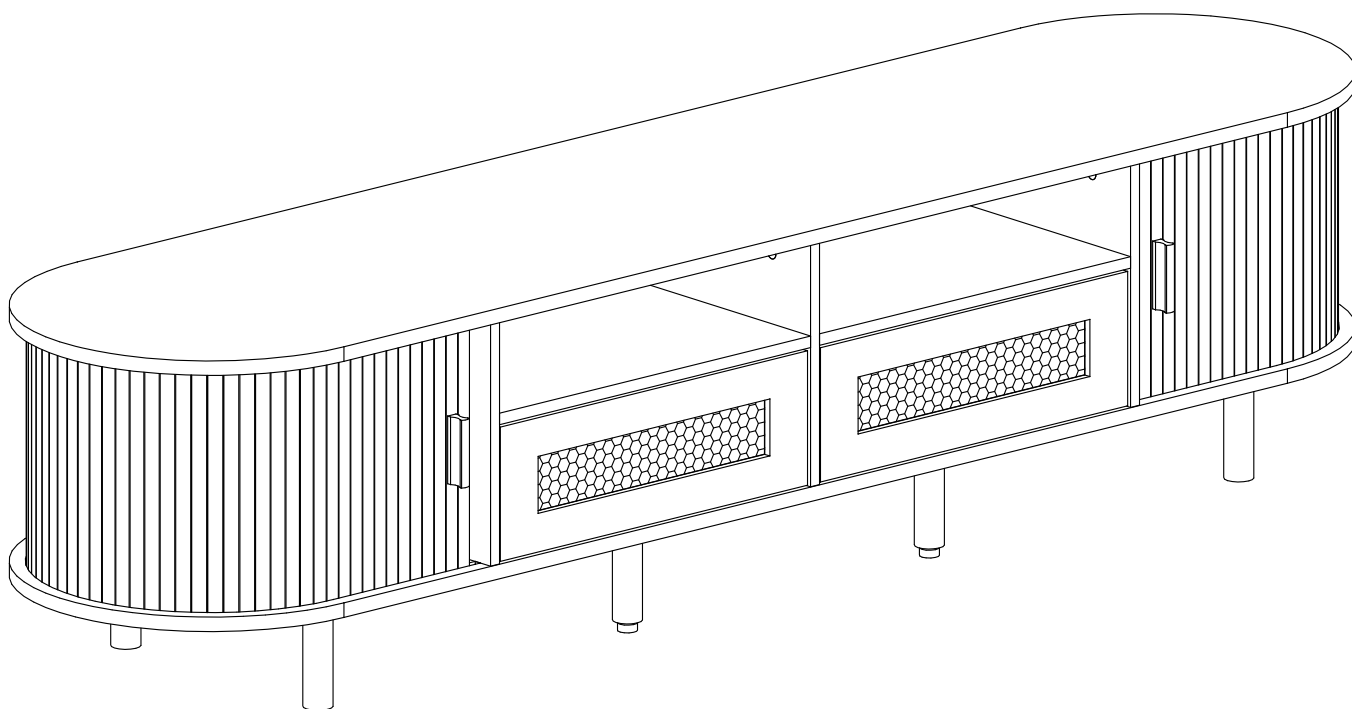

Product manual
Gebrauchsanweisung
Manuel du produit
Manual del producto
Manuale del prodotto



FR
Pensez à donner ou recycler.

Association ou Magasin ou Déchèterie

<https://quefairedemesdechets.fr>

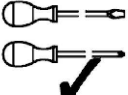
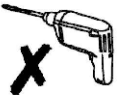
 2PERS	 45 MIN	Tool Required Not Provided  
--	--	---



[DE]

Warnung: Lesen Sie die Anleitung vor dem Zusammenbau bitte vollständig durch. Überprüfen Sie, ob Sie alle auf den Seiten aufgeführten Komponenten und Werkzeuge haben.

Warnung: Legen Sie alle Teile auf eine ebene Fläche. Legen Sie eine weiche Decke oder Ähnliches darunter, um sie vor Kratzern oder Flecken zu schützen. Vermeiden Sie es, Komponenten über den Boden zu ziehen oder zu schieben.

Warnung: Überprüfen Sie regelmäßig alle Beschläge und Befestigungen, um sicherzustellen, dass sie sicher sind und um Unfälle zu vermeiden. Wenn Teile fehlen, kaputt, beschädigt oder abgenutzt sind, verwenden Sie das Produkt nicht weiter, bis es mit vom Hersteller autorisierten Teilen repariert wurde.

Warnung: Lassen Sie Kinder nicht auf die Möbel klettern, da dies zum Umkippen und zu schweren Verletzungen führen kann. Bauen Sie die Möbel außerhalb der Reichweite von Kindern zusammen.

Warnung: Stellen Sie die Möbel nicht in die Nähe von Feuerquellen oder heißen Gegenständen, um Brandgefahr zu vermeiden.

Warnung: Reinigen Sie die Möbel mit einem feuchten Tuch oder Alkohol. Verwenden Sie keine Reinigungsmittel mit ätzenden Chemikalien.

Warnung: Dieses Produkt ist mit einer Kippschutzvorrichtung ausgestattet. Bitte installieren Sie diese Vorrichtung unbedingt, um unnötige Verletzungen durch Umkippen zu vermeiden.

[EN]

Warning: Please read instructions fully before starting assembly. Check you have all the components and tools listed on pages.

Warning: Please place all parts on a flat surface. Place a soft blanket or similar underneath to protect against scratches or stains. Avoid dragging or sliding components across the floor.

Warning: Regularly check all fittings and fastenings to ensure they are secure and to prevent accidents. If any parts are missing, broken, damaged, or worn, discontinue use of the product until repairs have been made using factory authorized parts.

Warning: Do not allow children to climb on the furniture as this may result in tipping and serious personal injury. Assemble the furniture away from the reach of children.

Warning: Do not place furniture close to fire sources or high-temperature objects to avoid the risk of fire.

Warning: Clean furniture with a damp cloth or alcohol, avoid using cleaning agents containing corrosive chemicals.

Warning: This product is equipped with an anti-tilt device. Please be sure to install this device to prevent unnecessary injuries caused by tipping.

[FR]

Avertissement : Veuillez lire attentivement ces instructions avant de commencer l'assemblage. Vérifiez que vous disposez de tous les composants et outils répertoriés sur les pages. Conservez les instructions pour référence ultérieure. Certaines parties de l'assemblage seront plus faciles à 2 personnes. Demandez l'aide d'un professionnel si nécessaire.

Avertissement : Veuillez placer toutes les pièces sur une surface plane. Placez une couverture douce ou similaire en dessous pour les protéger des rayures ou des taches. Évitez de faire glisser les composants sur le sol.

Avertissement : Vérifiez régulièrement tous les raccords et fixations pour vous assurer qu'ils sont bien fixés et pour éviter les accidents. Si des pièces manquent, sont cassées, endommagées ou usées, cessez d'utiliser le produit jusqu'à ce que des réparations aient été effectuées à l'aide de pièces autorisées par l'usine.

Avertissement : Ne laissez pas les enfants grimper sur les meubles car cela pourrait entraîner un basculement et des blessures graves. Assemblez les meubles hors de portée des enfants.

Avertissement : Ne placez pas les meubles à proximité de sources de feu ou d'objets à haute température pour éviter tout risque d'incendie.

Avertissement : Nettoyez les meubles avec un chiffon humide ou de l'alcool, évitez d'utiliser des produits de nettoyage contenant des produits chimiques corrosifs.

Avertissement : Ce produit est équipé d'un dispositif anti-basculement. Assurez-vous d'installer ce dispositif pour éviter les blessures inutiles causées par un basculement.

[IT]

Attenzione: leggere attentamente queste istruzioni prima di iniziare il montaggio. Verificare di avere tutti i componenti e gli strumenti elencati nelle pagine. Conservare le istruzioni per riferimento futuro. Alcune parti del montaggio saranno più facili con 2 persone. Se necessario, chiedere assistenza professionale.

Attenzione: posizionare tutte le parti su una superficie piana. Posizionare una coperta morbida o simile sotto per proteggere da graffi o macchie. Evitare di trascinare o far scivolare i componenti sul pavimento.

Attenzione: controllare regolarmente tutti i raccordi e i dispositivi di fissaggio per assicurarsi che siano sicuri e per prevenire incidenti. Se alcune parti sono mancanti, rotte, danneggiate o usurate, interrompere l'uso del prodotto fino a quando non siano state eseguite le riparazioni utilizzando parti autorizzate dalla fabbrica.

Attenzione: non consentire ai bambini di arrampicarsi sui mobili poiché ciò potrebbe causare ribaltamenti e gravi lesioni personali. Montare i mobili lontano dalla portata dei bambini.

Attenzione: non posizionare i mobili vicino a fonti di fuoco o oggetti ad alta temperatura per evitare il rischio di incendio

Attenzione: pulire i mobili con un panno umido o alcol, evitare di utilizzare detergenti contenenti sostanze chimiche corrosive.

Attenzione: questo prodotto è dotato di un dispositivo antiribaltamento. Assicurarsi di installare questo dispositivo per prevenire lesioni inutili causate dal ribaltamento.

[ES]

Advertencia: Lea estas instrucciones completamente antes de comenzar el montaje. Compruebe que tiene todos los componentes y herramientas que se enumeran en las páginas. Conserve las instrucciones para consultarlas más adelante. El montaje de algunas partes será más sencillo con 2 personas. Busque ayuda profesional si es necesario.

Advertencia: Coloque todas las piezas sobre una superficie plana. Coloque una manta suave o algo similar debajo para protegerlas de rayones o manchas. Evite arrastrar o deslizar los componentes por el piso.

Advertencia: Verifique regularmente todos los accesorios y fijaciones para asegurarse de que estén seguros y evitar accidentes. Si falta alguna pieza, está rota, dañada o desgastada, deje de usar el producto hasta que se hayan realizado las reparaciones con piezas autorizadas de fábrica.

Advertencia: No permita que los niños se suban a los muebles, ya que esto puede provocar que se vuelquen y lesiones personales graves. Monte los muebles fuera del alcance de los niños.

Advertencia: No coloque los muebles cerca de fuentes de fuego u objetos de alta temperatura para evitar el riesgo de incendio.

Advertencia: Limpie los muebles con un paño húmedo o alcohol, evite usar agentes de limpieza que contengan químicos corrosivos.

Advertencia: Este producto está equipado con un dispositivo antivuelco. Asegúrese de instalar este dispositivo para evitar lesiones innecesarias causadas por vuelcos.

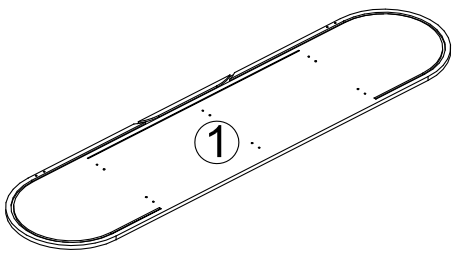
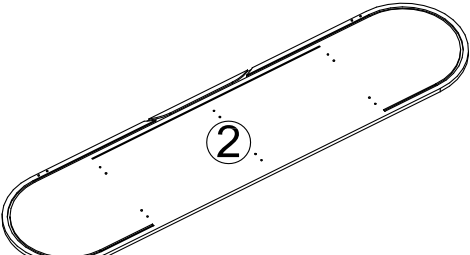
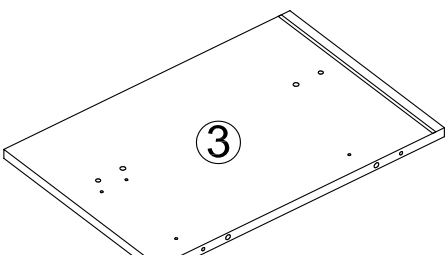
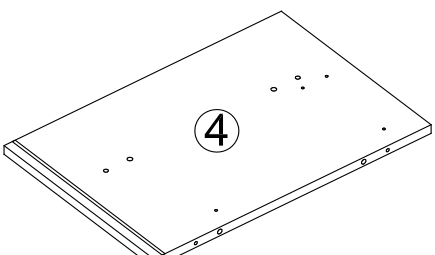
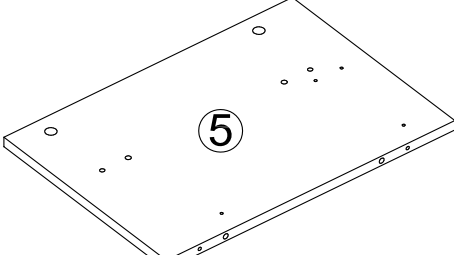
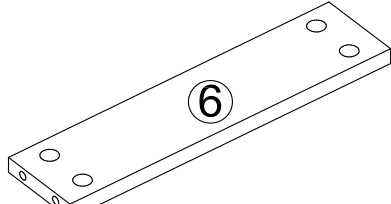
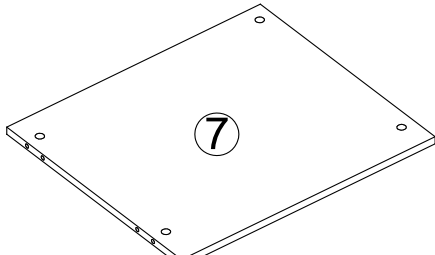
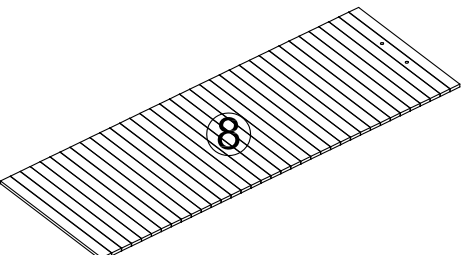
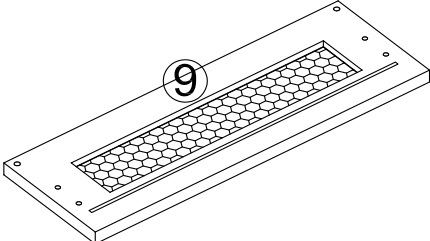
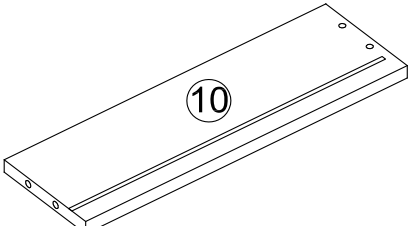
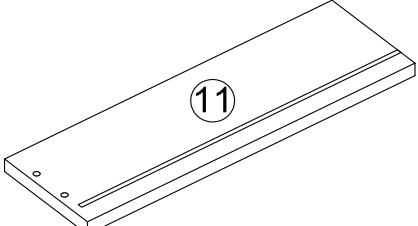
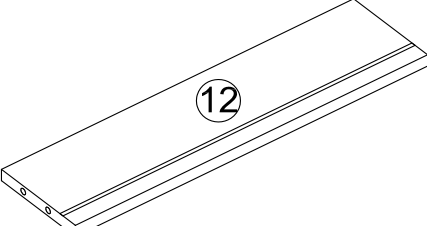
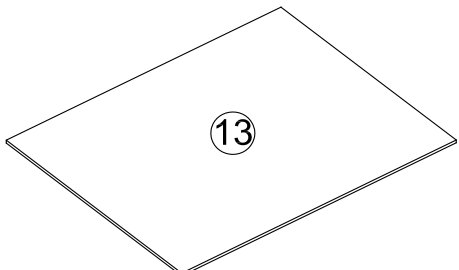
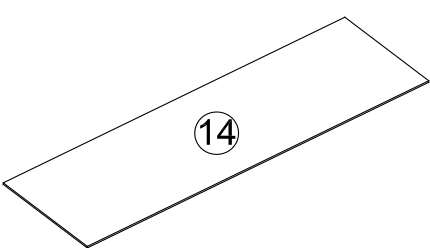
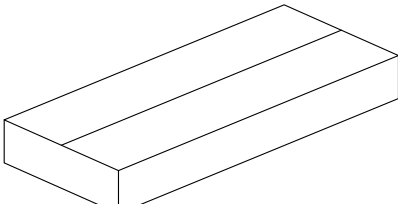

N892P433765

 <p>1</p>	 <p>2</p>	 <p>3</p>
1PC	1PC	1PC
 <p>4</p>	 <p>5</p>	 <p>6</p>
1PC	1PC	2PCS
 <p>7</p>	 <p>8</p>	 <p>9</p>
2PCS	2PCS	2PCS
 <p>10</p>	 <p>11</p>	 <p>12</p>
2PCS	2PCS	2PCS
 <p>13</p>	 <p>14</p>	 <p>400x250x40 (Hardware fittings)</p>
2PCS	1PC	

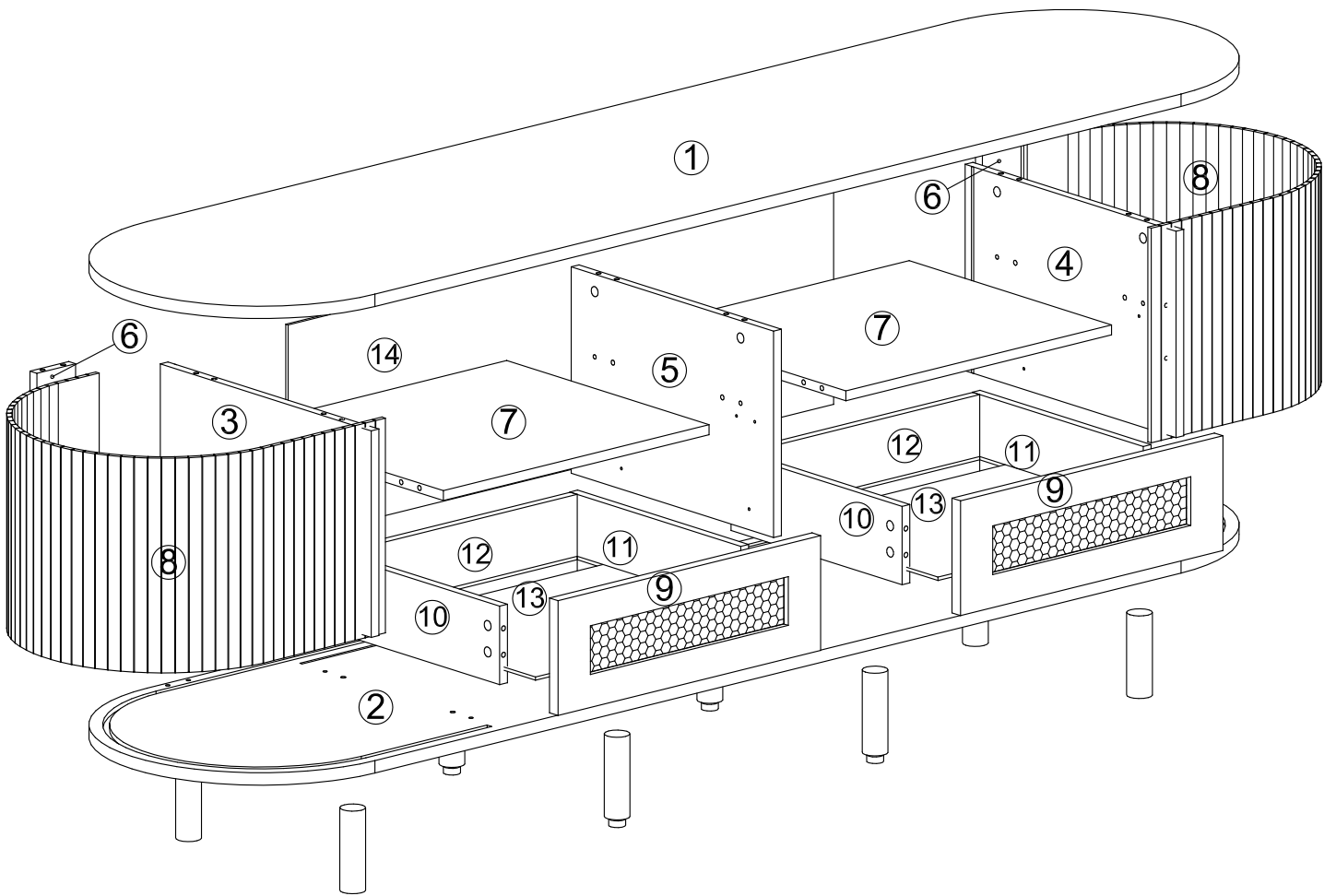
PARTS

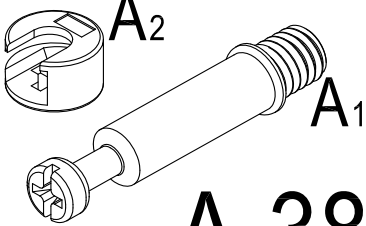
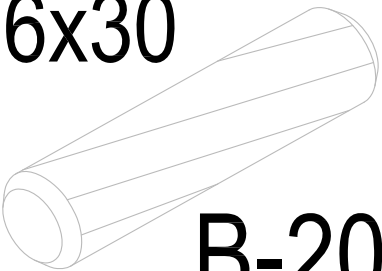
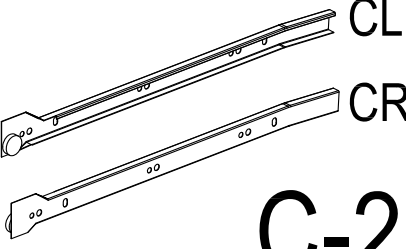
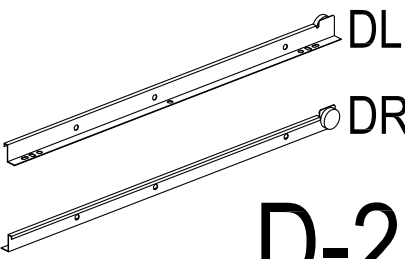
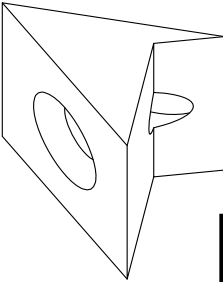
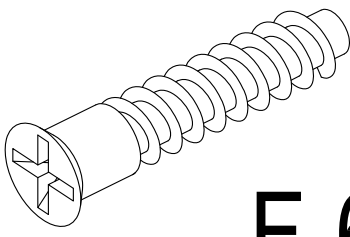
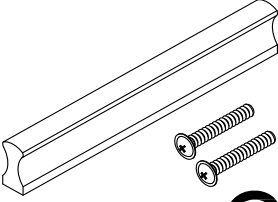
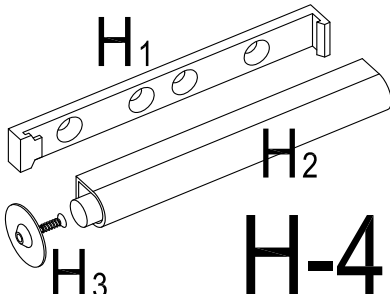
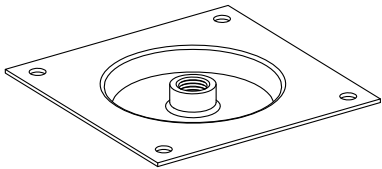
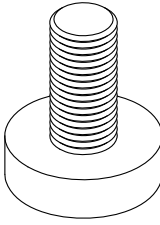

Hardware of N892P433765

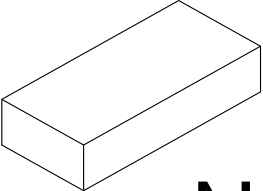
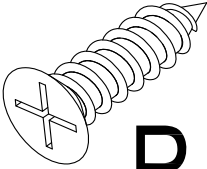
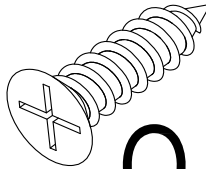
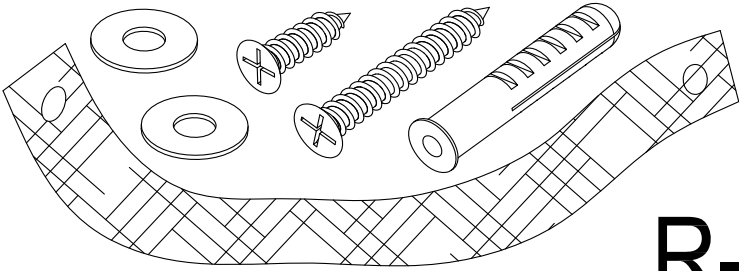
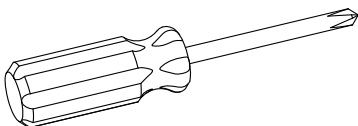
 <p>A-38</p>	<p>6x30</p>  <p>B-20</p>	 <p>C-2</p>
 <p>D-2</p>	 <p>E-4</p>	 <p>F-6</p>
 <p>G-2</p>	 <p>H-4</p>	 <p>J-8</p>
 <p>K-4</p>	<p>30x110</p>  <p>L-4</p>	<p>30x100</p>  <p>M-4</p>
 <p>N-1</p>	<p>3.5x12</p>  <p>P-24</p>	<p>3.5x14</p>  <p>Q-36</p>
 <p>R-2</p>		

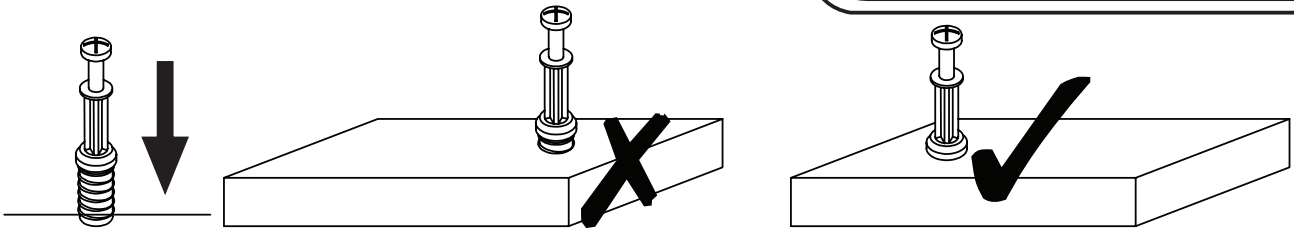

EN_QUICKFIT: Tighten quickfit until shoulder is flush with panel. Do not overtighten or undertighten.

FR_RACCORD RAPIDE: Faites serrer le raccord rapide jusqu'à ce que l'épaulement soit parfaitement encastré dans le panneau. Il ne faut ni trop serrer ni insuffisamment serrer.

ES_QUICKFIT: Apriete quickfit hasta que el hombro se descargue con el panel. NO lo sobreapriete ni lo apriete poco.

DE_QUICKFIT: Ziehen Sie den Quickfit fest, bis die Schulter mit der Platte bündig ist. Bitte nicht zu fest oder zu schwach anziehen.

IT_MONTAGGIO RAPIDO: Stringere il montaggio rapido fino a quando la spalla è a filo con il pannello, non stringere troppo o troppo poco.

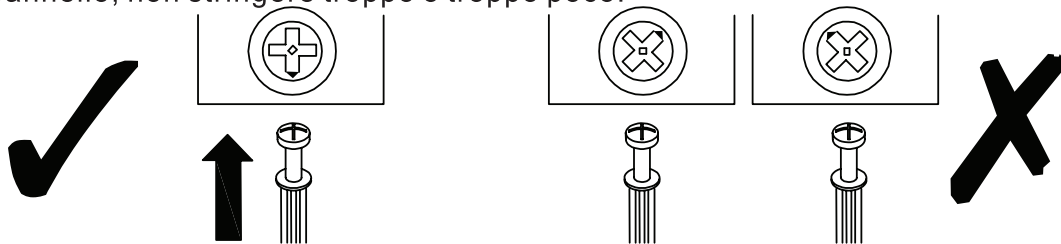

EN_CAM LOCK: When fitting cam lock, ensure starting position is correct before you insert connecting quickfit.

FR_SERRURE BATTEUSE: Avant d'insérer la serrure batteuse, veillez à la bonne orientation avant d'insérer le raccord rapide.

ES_CIERRE DE LA CÁMARA: Cuando instale el cierre de la cámara, asegúrese de que la posición de inicio es correcta antes de que inserte el quickfit conector.

DE_CAM-LOCK: Achten Sie bei der Montage des Cam-Locks auf die richtige Ausgangsposition, bevor Sie den Quickfit einsetzen.

IT_BLOCCAGGIO A CAMMA: Quando si monta il bloccaggio a camma, assicurarsi che la posizione iniziale sia corretta prima di inserire il montaggio rapido di collegamento.

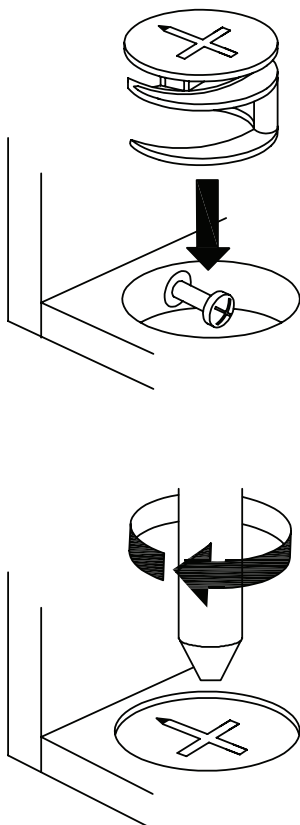

EN_Quickfit head should be in the centre of the cam lock when the two panels are joined.

Cam lock should be inserted before quickfit.

FR_Lorsque les deux panneaux sont assemblés, la tête du raccord rapide doit reposer au centre de la serrure batteuse. Il faut insérer la serrure batteuse avant le raccord rapide.

ES_El cabezal del quickfit debe estar en el centro del cierre de la cámara cuando se unan los dos paneles.

Se debe insertar el cierre de la cámara antes que el quickfit.

DE_Der Quickfit-Kopf sollte sich in der Mitte des Cam-Locks befinden, wenn die beiden Platten zusammengefügt sind. Der Cam-Lock sollte vor dem Quickfit eingesetzt werden.

IT_La testa del montaggio rapido deve trovarsi al centro del bloccaggio a camma quando i due pannelli sono uniti.

Il Bloccaggio a Camma deve essere inserito prima del montaggio rapido.

EN_Turn cam lock clockwise to tighten.

FR_Faites tourner la serrure batteuse dans le sens des aiguilles d'une montre pour la resserrer.

ES_Gire el cierre de la cámara en sentido horario para apretarlo.

DE_Drehen Sie den Cam-Lock im Uhrzeigersinn, um ihn festzuziehen.

IT_Ruotare il bloccaggio a camma in senso orario per stringere.

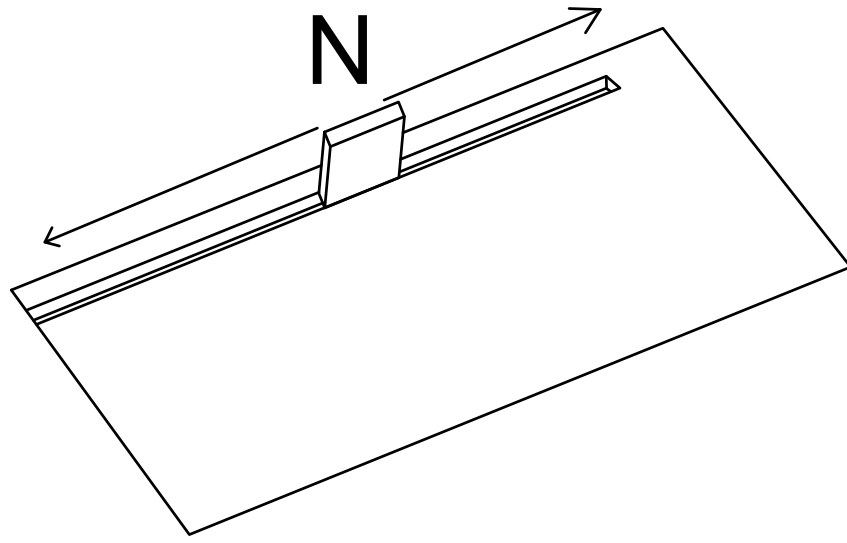

EN_Apply the wax block to the groove. Repeat 2-3 times.

FR_Appliquer le bloc de cire dans les rainures. Répétez 2-3 fois.

ES_Aplicar el bloque de cera en las ranuras. Repita 2-3 veces.

DE_Trage das wachs in die rillen ein. Ich wiederhole 2-3.

IT_Mettere il blocco di cera in una scanalatura. Ripetere 2-3 volte.

2

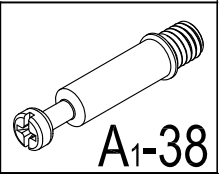
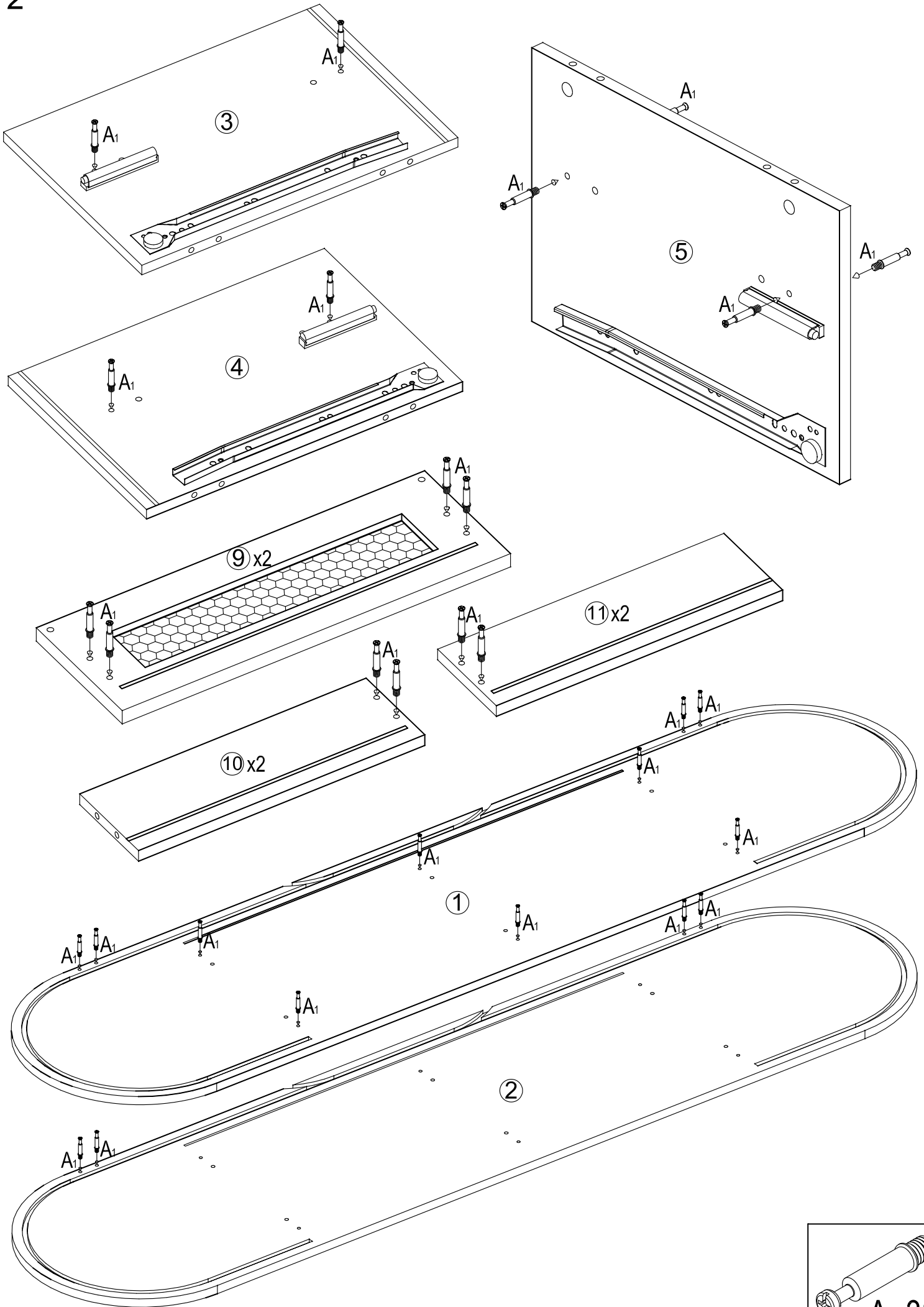

3

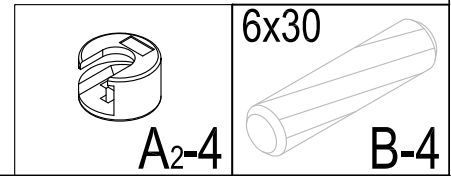
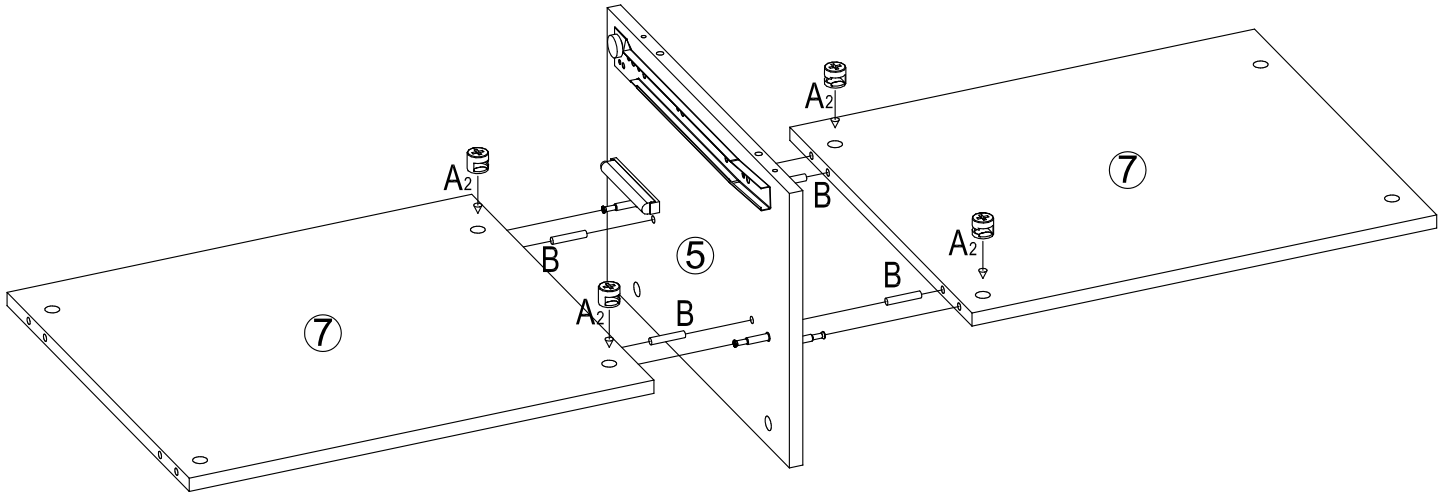

4

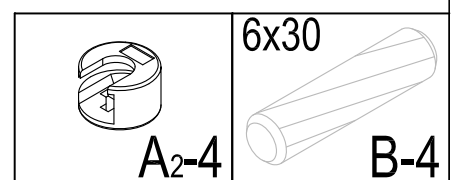
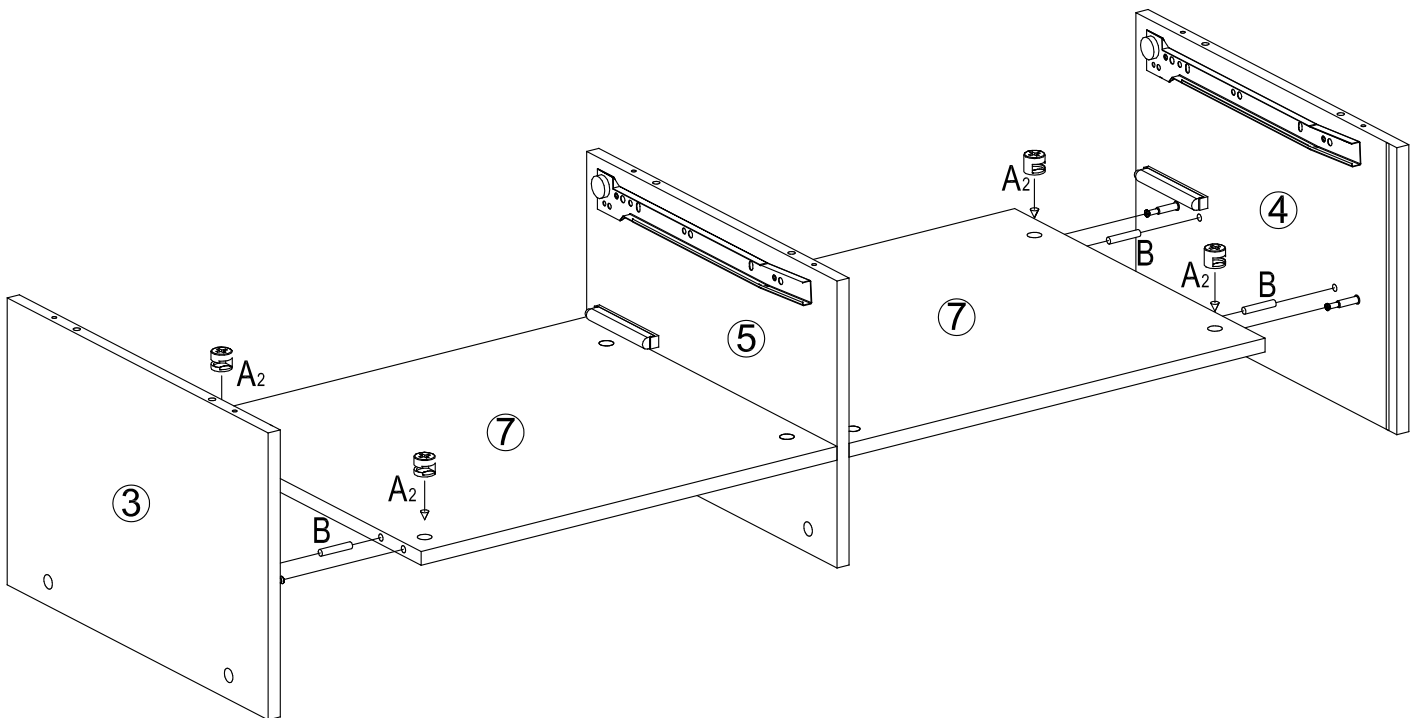

5

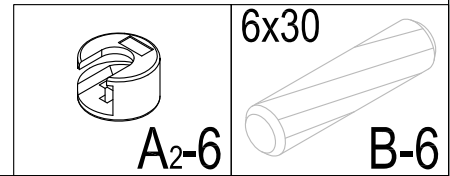
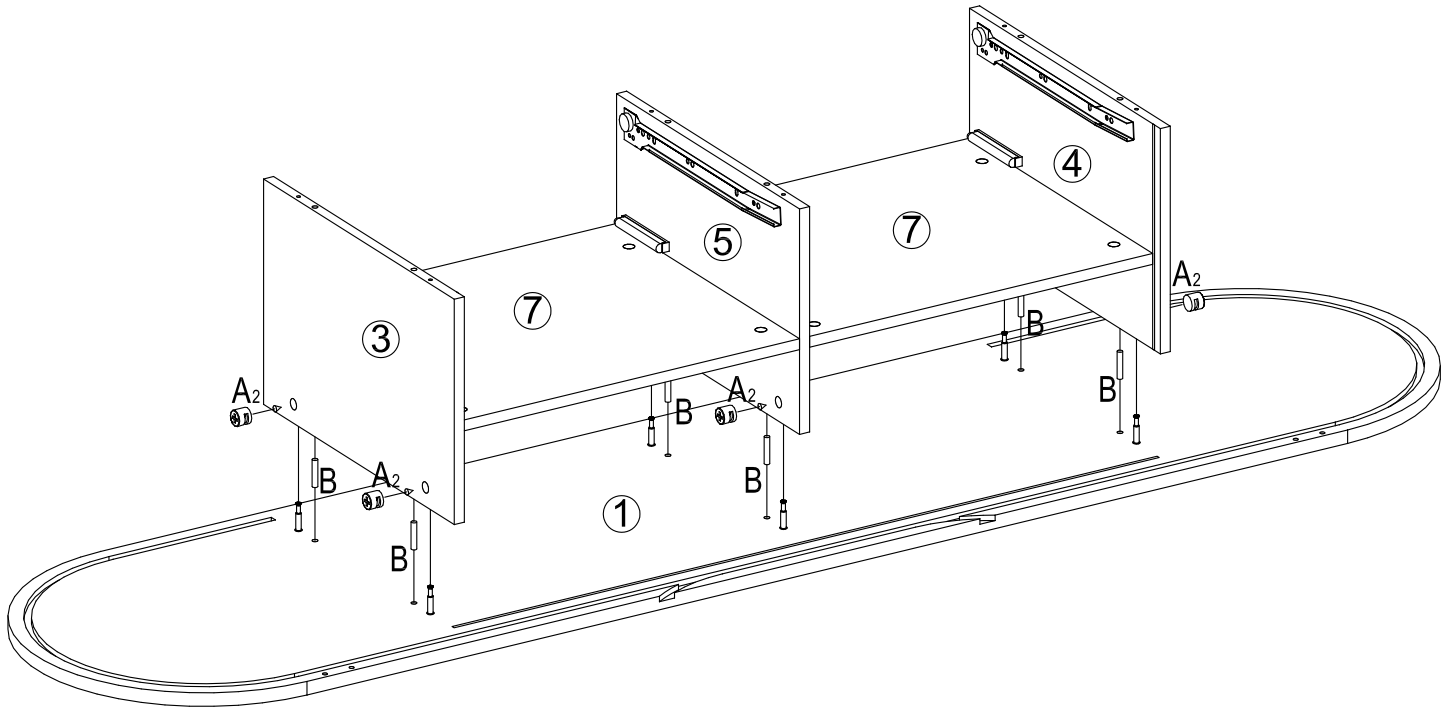

6

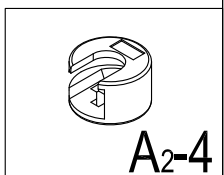
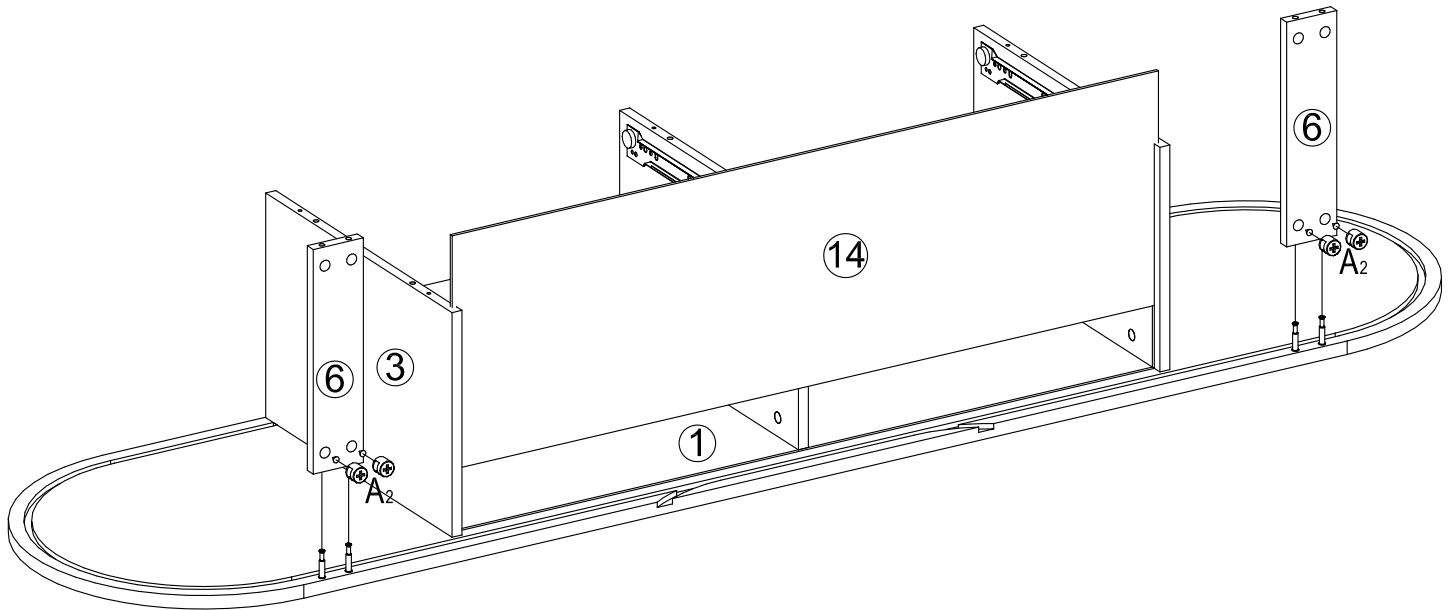

7

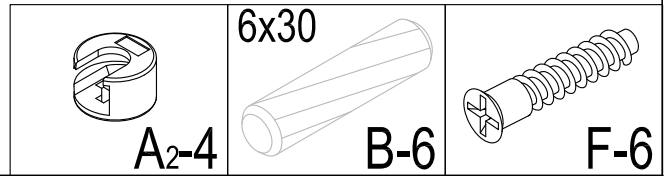
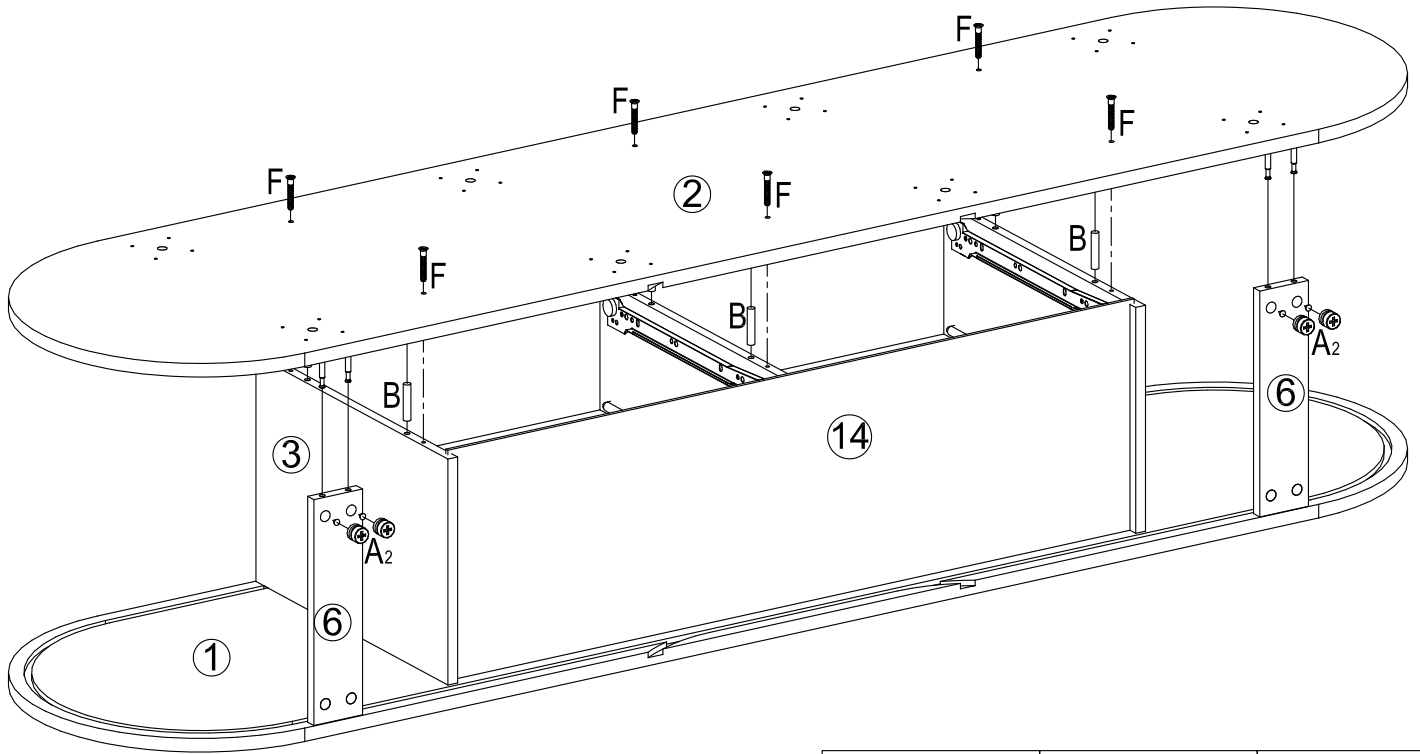

8

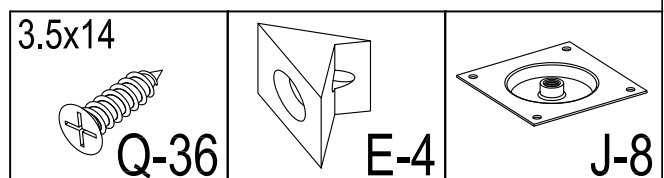
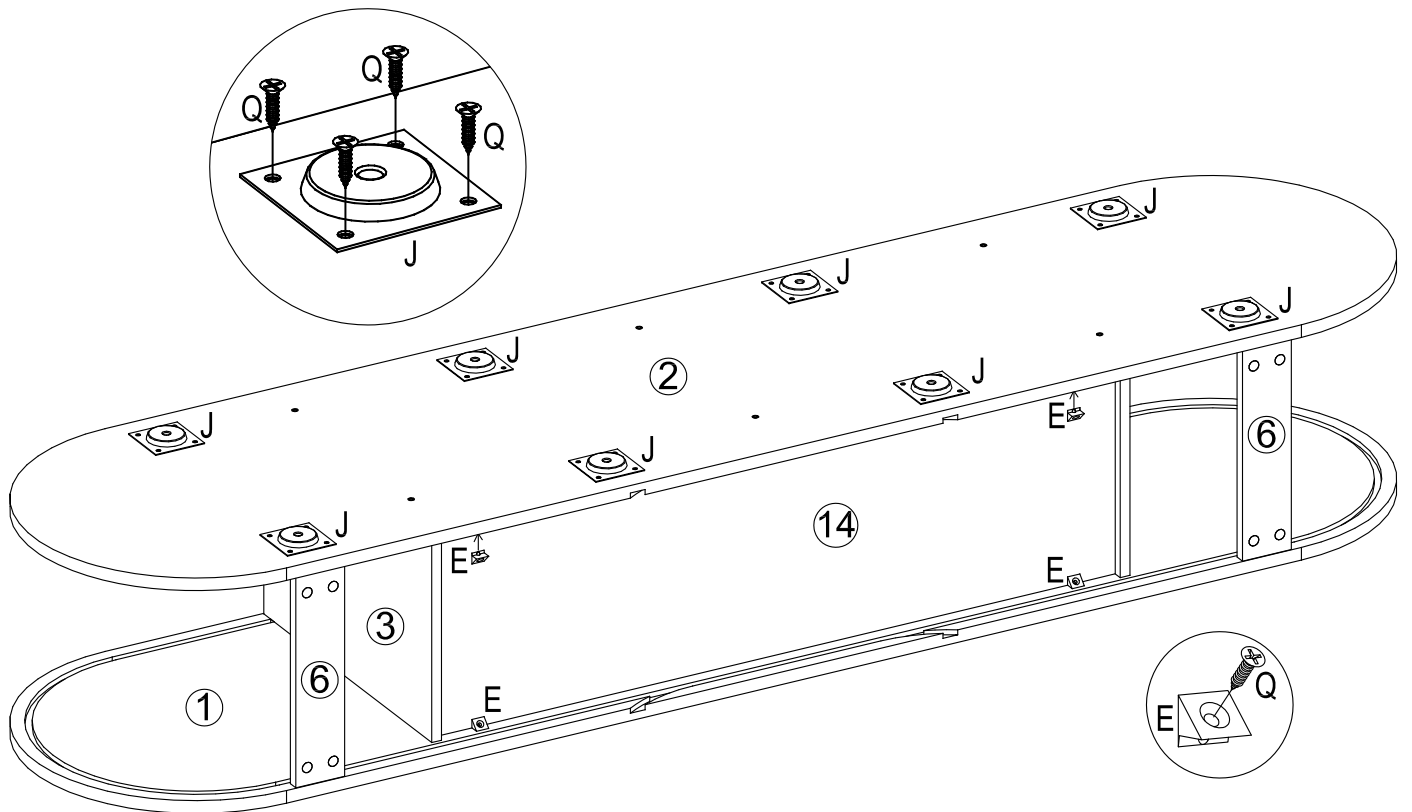

9

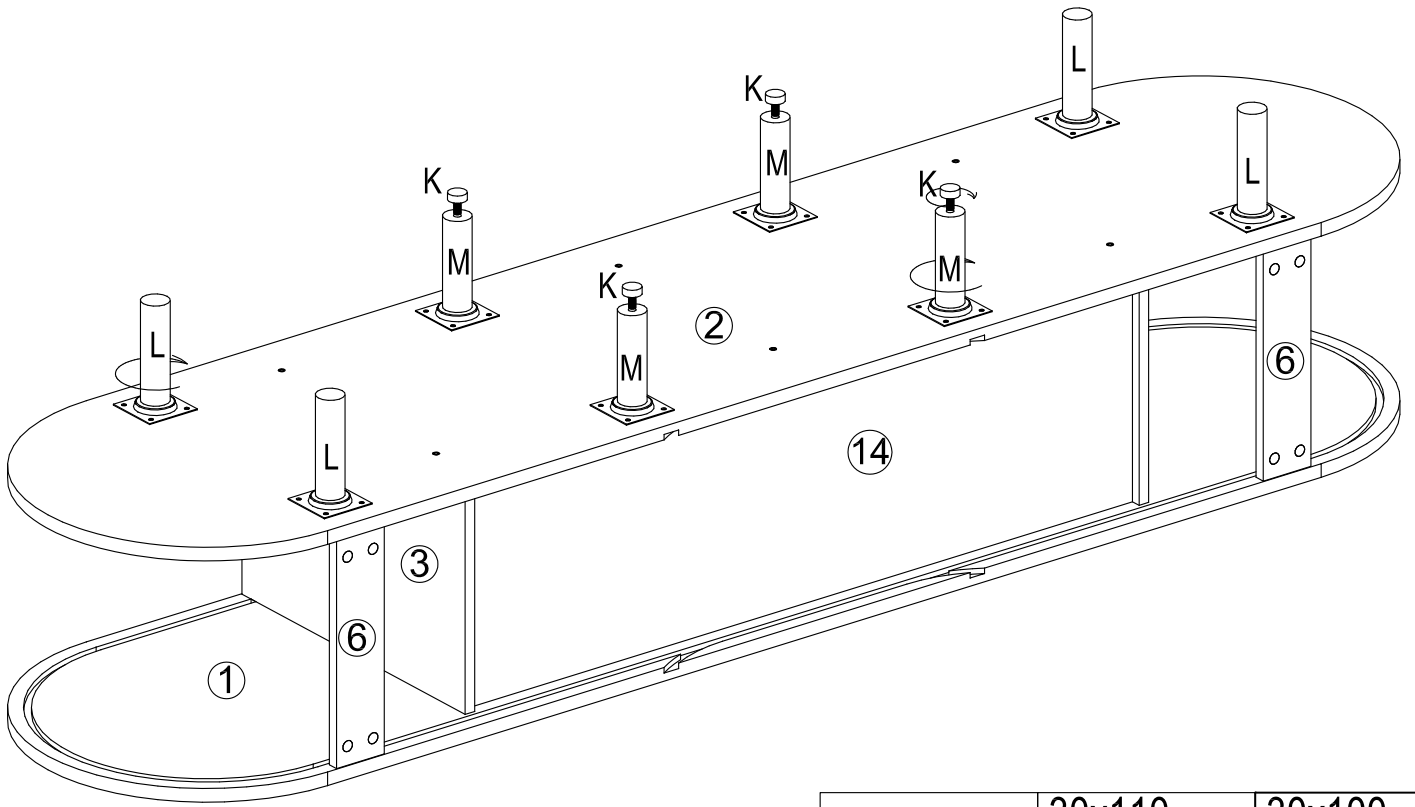

10

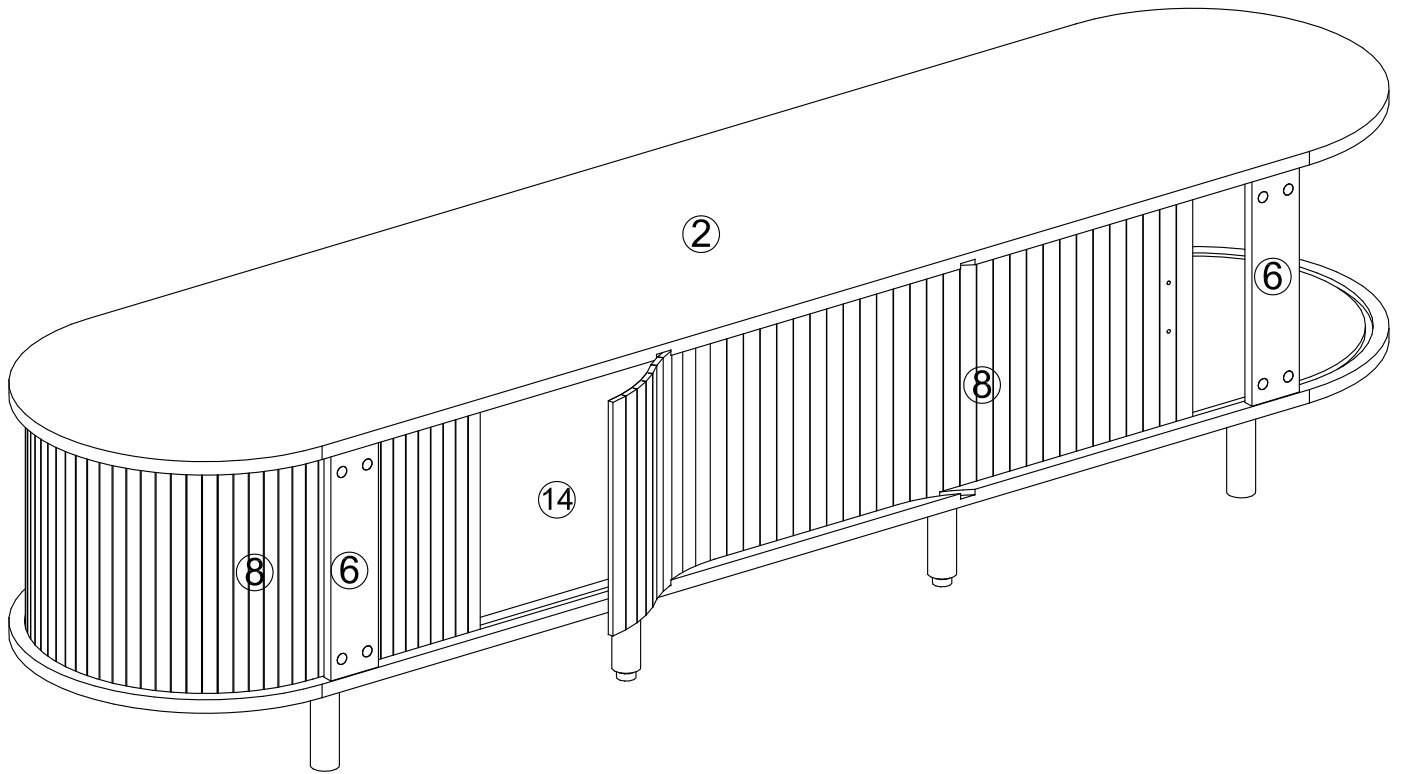

11

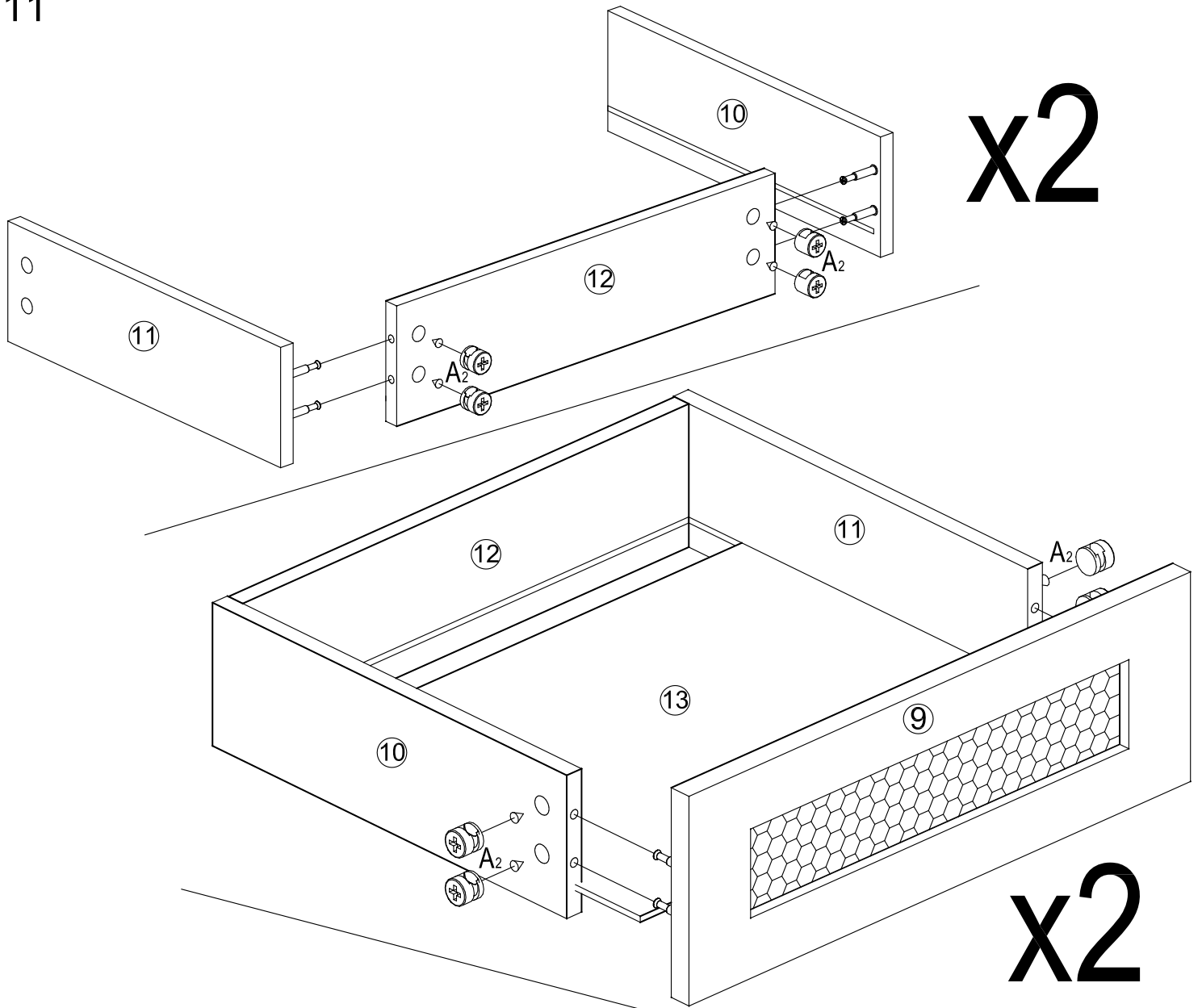

x2

x2

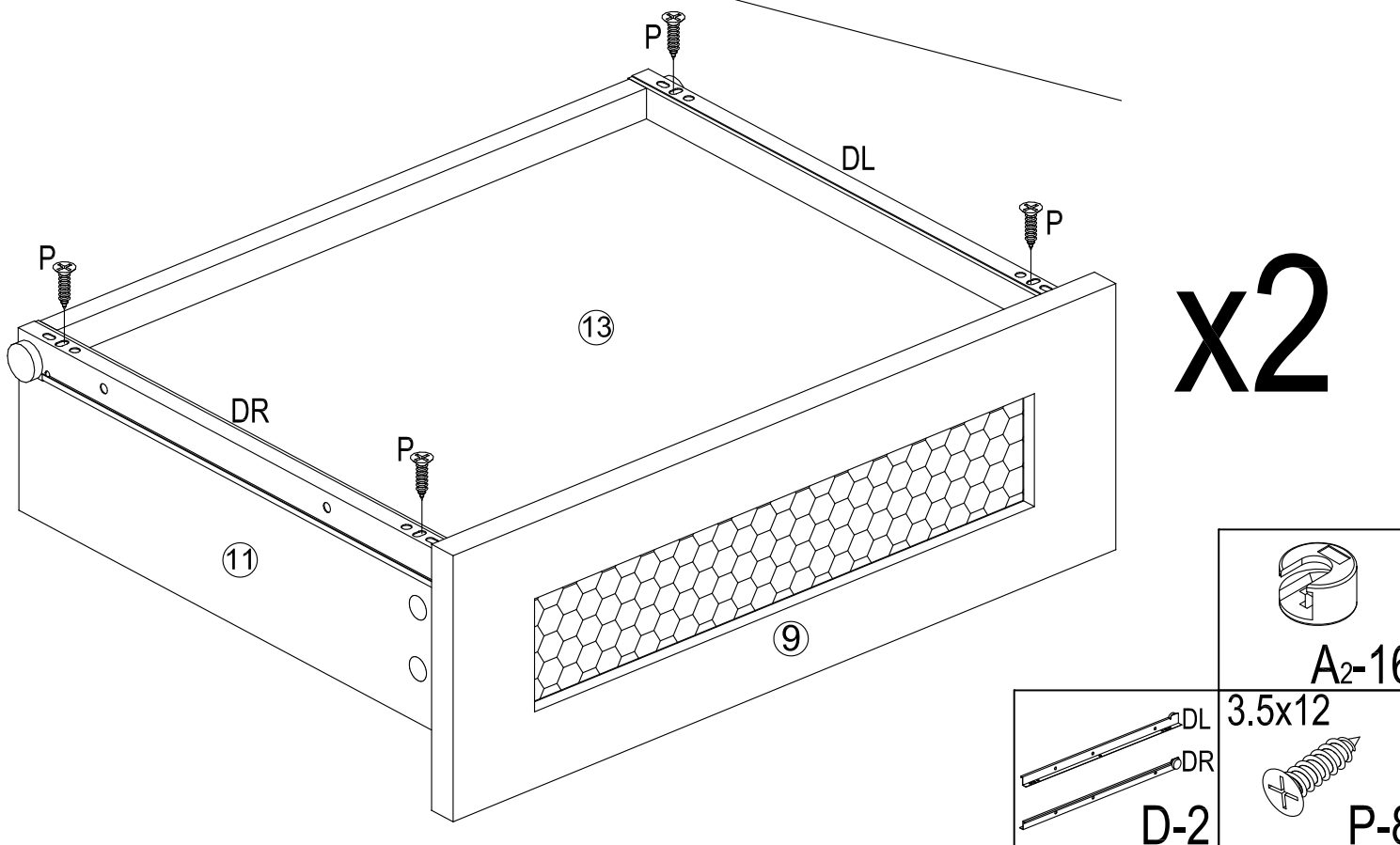

x2

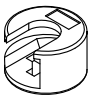

A2-16

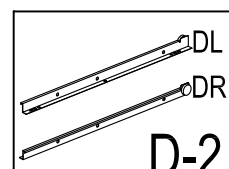

3.5x12

D-2

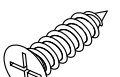

P-8

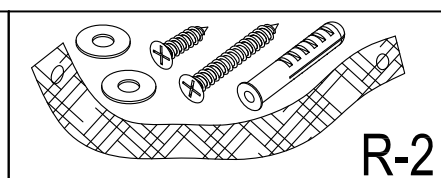
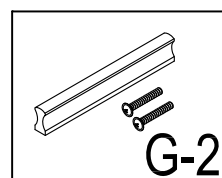
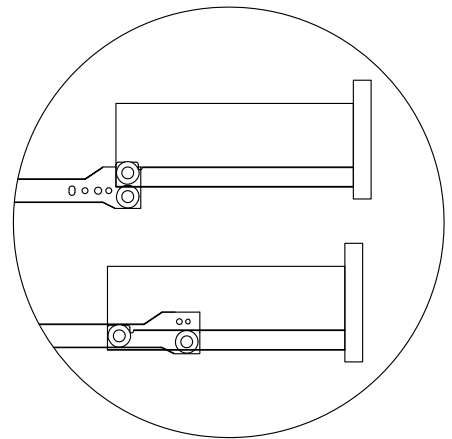
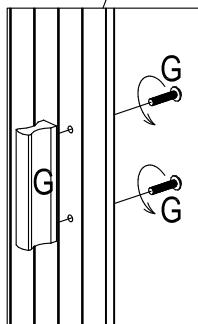
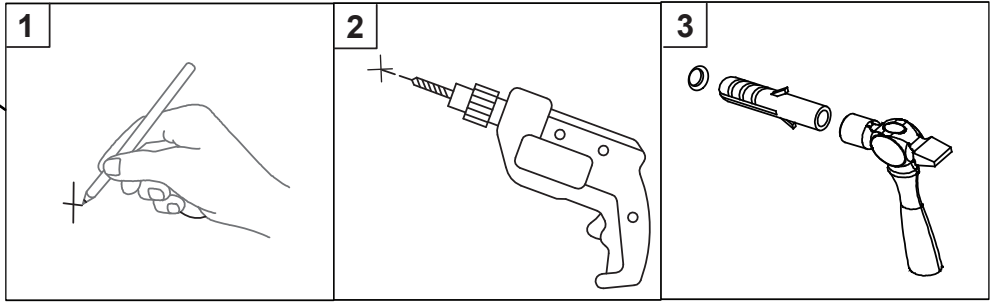
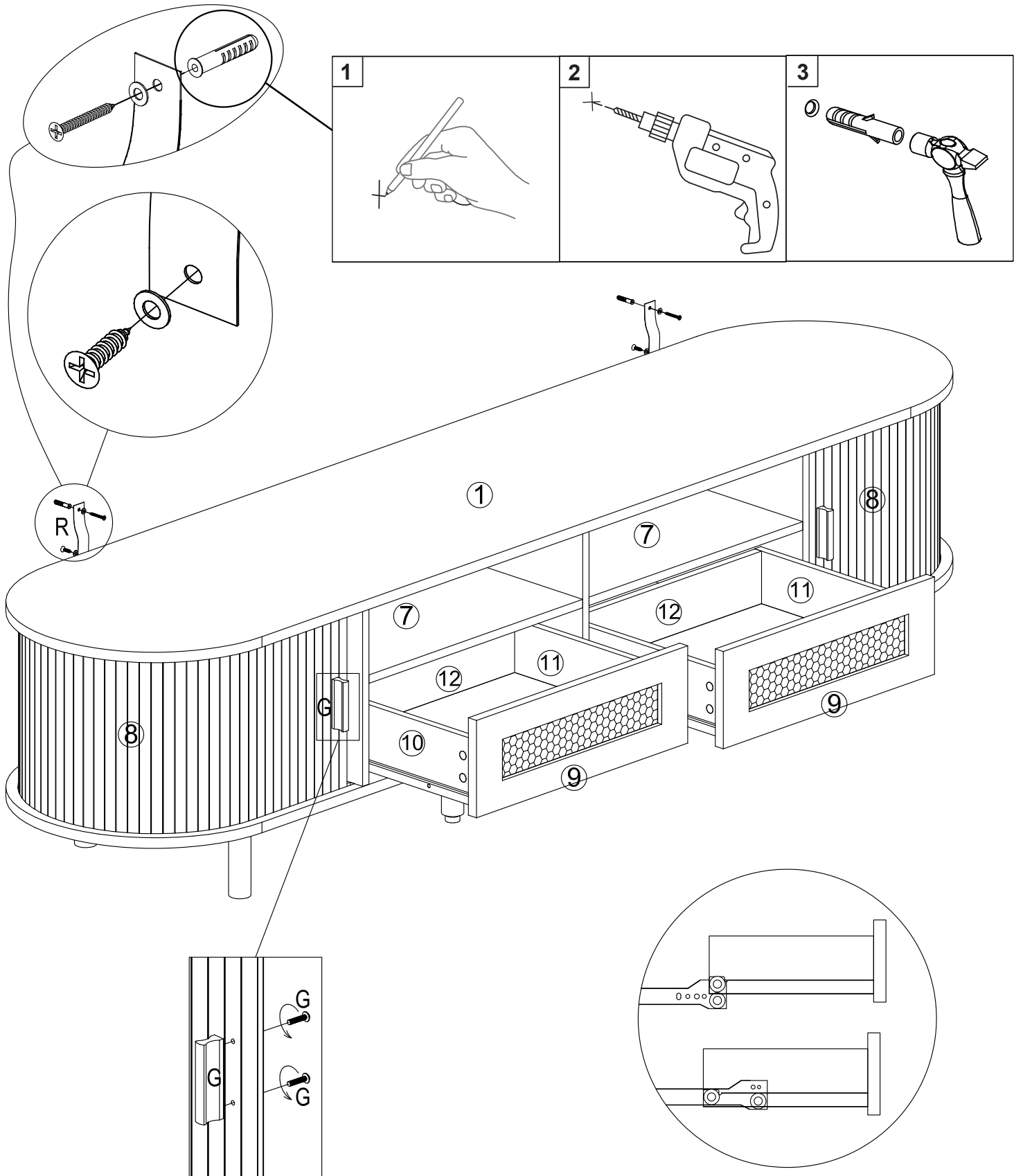

DE: Wenn die Schublade/Tür mit Auslöser (Teil: H) nach außen vorsteht, drehen Sie den Auslöser im Uhrzeigersinn, bis er sanft die Innenseite der Front berührt.

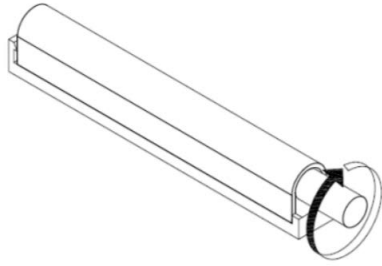

FR: Si le tiroir/porte avec loquet (Pièce : H) dépasse vers l'extérieur, tournez le loquet dans le sens horaire jusqu'à ce qu'il touche légèrement l'intérieur du panneau.

EN: If the drawer/door with push-latch (Part: H) protrudes outward, rotate the latch clockwise until it gently touches the inner side of the panel.

IT: Se il cassetto/anta con dispositivo (Parte: H) sporge verso l'esterno, ruotare il dispositivo in senso orario finché non tocca leggermente la parte interna del pannello.

ES: Si el cajón/puerta con mecanismo de retroceso (Pieza: H) sobresale hacia afuera, gire el mecanismo en sentido horario hasta que toque suavemente el interior del panel.

DE: Wenn die Schublade/Tür mit Auslöser (Teil: H) nach innen versenkt ist, drehen Sie den Auslöser gegen den Uhrzeigersinn, bis er sanft die Innenseite der Front berührt.

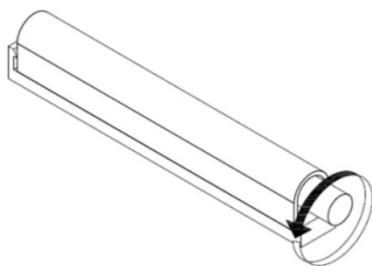

FR: Si le tiroir/porte avec loquet (Pièce : H) est enfoncé vers l'intérieur, tournez le loquet dans le sens antihoraire jusqu'à ce qu'il touche légèrement l'intérieur du panneau.

EN: If the drawer/door with push-latch (Part: H) is recessed inward, rotate the latch counterclockwise until it gently touches the inner side of the panel.

IT: Se il cassetto/anta con dispositivo (Parte: H) è rientrato verso l'interno, ruotare il dispositivo in senso antiorario finché non tocca leggermente la parte interna del pannello.

ES: Si el cajón/puerta con mecanismo de retroceso (Pieza: H) está hundido hacia adentro, gire el mecanismo en sentido antihorario hasta que toque suavemente el interior del panel.

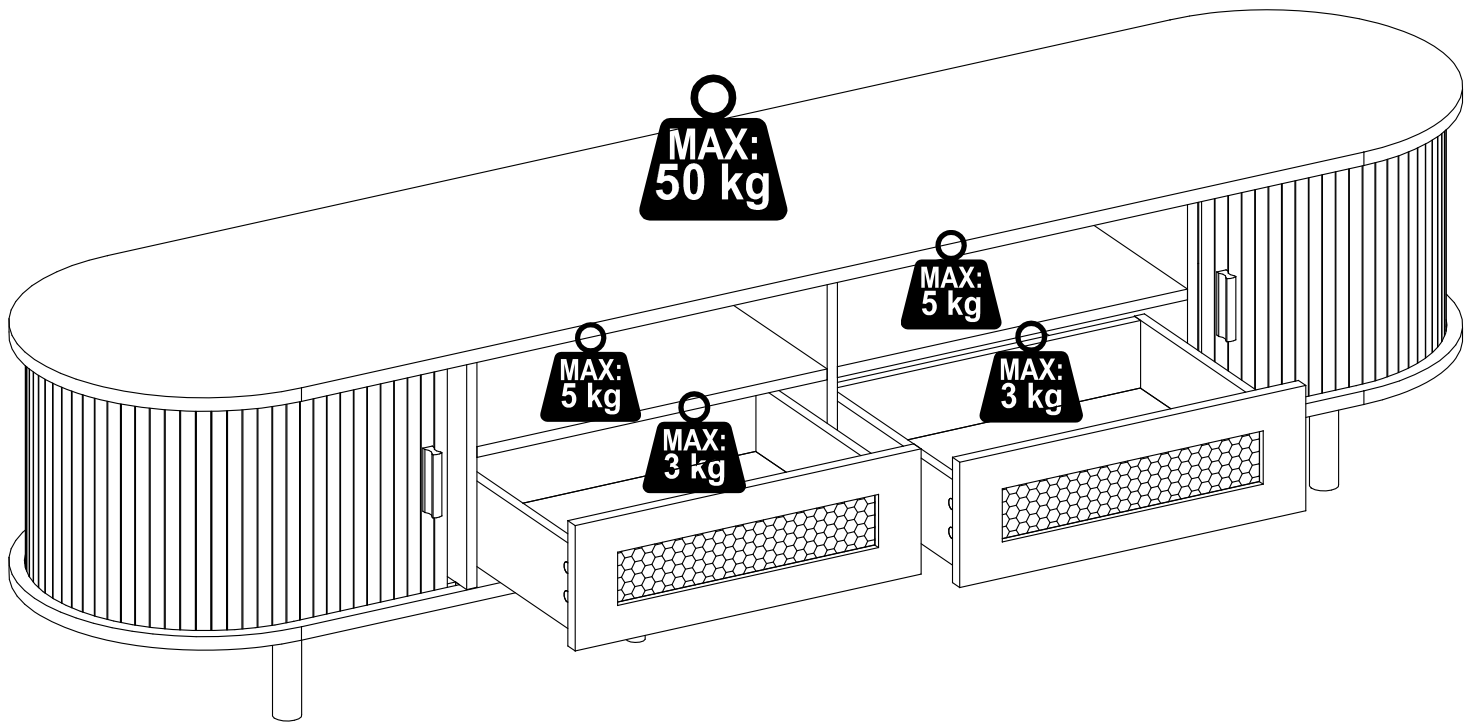

DE: Wenn Sie bemerken, dass die obere Platte in der Mitte durchhängt, drehen Sie den mittleren Fuß so, dass er weiter vom Boden entfernt ist.
 EN: If you notice the top plate sagging in the middle, rotate the middle foot so it is farther from the ground.

IT: Se notate che il piano superiore si incurva al centro, ruotate il piedino centrale in modo che sia più lontano dal terreno.

FR: Si vous remarquez que la plaque supérieure s'affaisse au centre, tournez le pied central pour qu'il soit plus éloigné du sol.

ES: Si observa que la placa superior se hunde en el centro, gire el pie central para que quede más alejado del suelo.

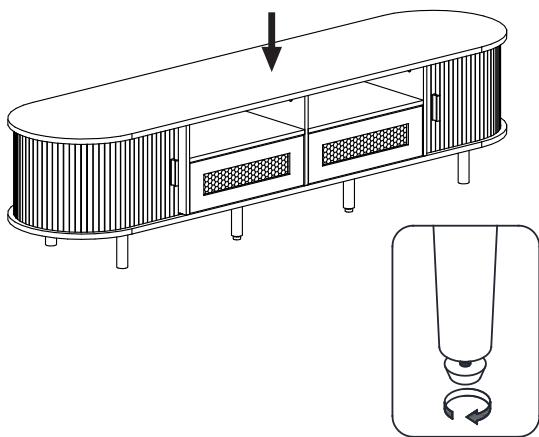

DE: Wenn Sie feststellen, dass die obere Platte sich in der Mitte nach oben wölbt, drehen Sie den mittleren Fuß so, dass er näher am Boden ist.

EN: If you notice that the top plate is bulging upward in the middle, rotate the middle foot so it is closer to the ground.

IT: Se notate che il piano superiore si gonfia verso l'alto al centro, ruotate il piedino centrale in modo che sia più vicino al terreno.

FR: Si vous remarquez que la plaque supérieure bombe vers le haut au centre, tournez le pied central pour qu'il soit plus proche du sol.

ES: Si observa que la placa superior se abomba hacia arriba en el centro, gire el pie central para que quede más cerca del suelo.

