

N892P417192W

N892P417192B

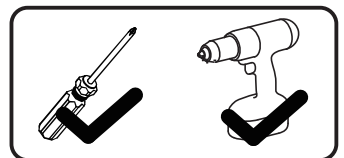

Product manual
Gebrauchsanweisung
Manuel du produit
Manual del producto
Manuale del prodotto

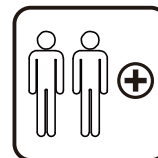
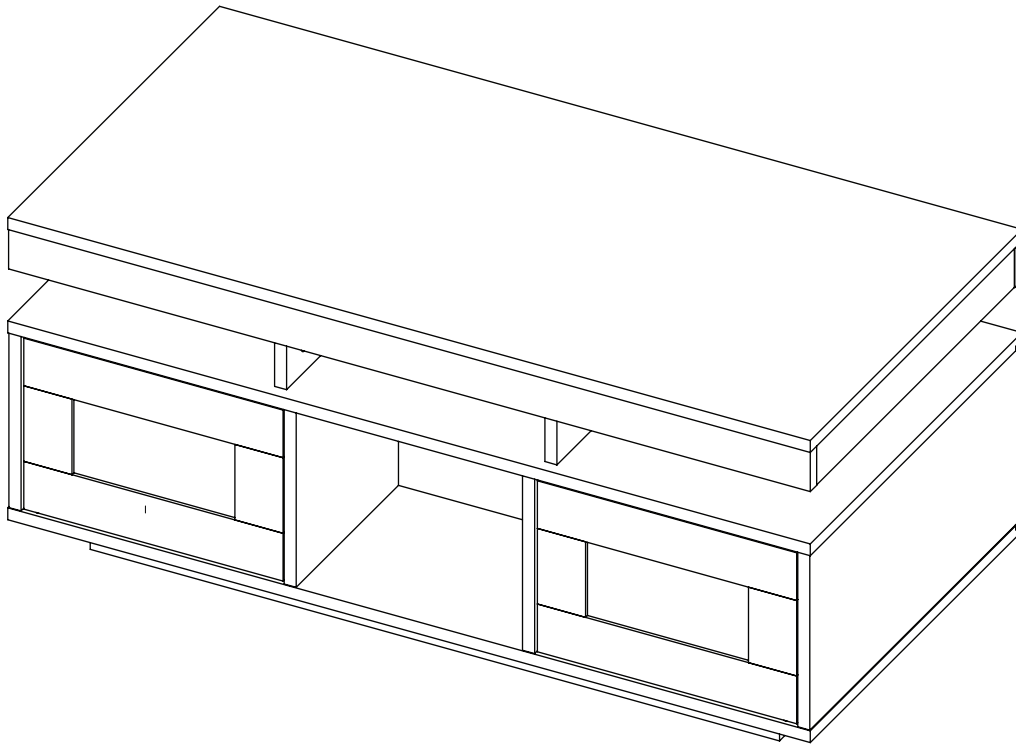

EN_ IMPORTANT, RETAIN FOR FUTURE REFERENCE: READ CAREFULLY.

FR_ IMPORTANT: A LIRE ATTENTIVEMENT ET À CONSERVER POUR CONSULTATION ULTÉRIEURE.

ES_ IMPORTANTE, LEA Y GUARDE PARA FUTURAS REFERENCIAS.

DE_ , WICHTIG! SORGFÄLTIG LESEN UND FÜR SPÄTER NACHSCHLAGEN AUFBEWAHREN."

IT_ IMPORTANTE! CONSERVARE IL PRESENTE MANUALE PER FUTURO RIFERIMENTO E LEGGERLO ATTENTAMENTE.



[DE]

Warnung: Lesen Sie diese Anleitung vor dem Zusammenbau bitte vollständig durch. Überprüfen Sie, ob Sie alle auf den Seiten aufgeführten Komponenten und Werkzeuge haben. Bewahren Sie die Anleitung zum späteren Nachschlagen auf. Teile des Zusammenbaus lassen sich mit 2 Personen leichter durchführen. Suchen Sie bei Bedarf professionelle Hilfe.

Warnung: Legen Sie alle Teile auf eine ebene Fläche. Legen Sie eine weiche Decke oder Ähnliches darunter, um sie vor Kratzern oder Flecken zu schützen. Vermeiden Sie es, Komponenten über den Boden zu ziehen oder zu schieben.

sind und um Unfälle zu vermeiden. Wenn Teile fehlen, kaputt, beschädigt oder abgenutzt sind, verwenden Sie das Produkt nicht weiter, bis es mit vom Hersteller autorisierten Teilen repariert wurde.

Warnung: Lassen Sie Kinder nicht auf die Möbel klettern, da dies zum Umkippen und zu schweren Verletzungen führen kann. Bauen Sie die Möbel außerhalb der Reichweite von Kindern zusammen.

Warnung: Stellen Sie die Möbel nicht in die Nähe von Feuerquellen oder heißen Gegenständen, um Brandgefahr zu vermeiden.

Warnung: Reinigen Sie die Möbel mit einem feuchten Tuch oder Alkohol. Verwenden Sie keine Reinigungsmittel mit ätzenden Chemikalien.

[EN]

Warning: Please read these instructions fully before starting assembly. Check you have all the components and tools listed on pages. Keep the instructions for later reference. Parts of the assembly will be easier with 2 people. Seek professional assistance if necessary.

Warning: Please place all parts on a flat surface. Place a soft blanket or similar underneath to protect against scratches or stains. Avoid dragging or sliding components across the floor.

Warning: Regularly check all fittings and fastenings to ensure they are secure and to prevent accidents. If any parts are missing, broken, damaged, or worn, discontinue use of the product until repairs have been made using factory authorized parts.

Warning: Do not allow children to climb on the furniture as this may result in tipping and serious personal injury. Assemble the furniture away from the reach of children.

Warning: Do not place furniture close to fire sources or high-temperature objects to avoid the risk of fire. Do not place furniture in damp environments to prevent material damage.

Warning: Clean furniture with a damp cloth or alcohol, avoid using cleaning agents containing corrosive chemicals.

[FR]

Avertissement : Veuillez lire attentivement ces instructions avant de commencer l'assemblage. Vérifiez que vous disposez de tous les composants et outils répertoriés sur les pages. Conservez les instructions pour référence ultérieure. Certaines parties de l'assemblage seront plus faciles à 2 personnes. Demandez l'aide d'un professionnel si nécessaire.

Avertissement : Veuillez placer toutes les pièces sur une surface plane. Placez une couverture douce ou similaire en dessous pour les protéger des rayures ou des taches. Évitez de faire glisser les composants sur le sol.

Avertissement : Vérifiez régulièrement tous les raccords et fixations pour vous assurer qu'ils sont bien fixés et pour éviter les accidents. Si des pièces manquent, sont cassées, endommagées ou usées, cessez d'utiliser le produit jusqu'à ce que des réparations aient été effectuées à l'aide de pièces autorisées par l'usine.

Avertissement : Ne laissez pas les enfants grimper sur les meubles car cela pourrait entraîner un basculement et des blessures graves. Assemblez les meubles hors de portée des enfants.

Avertissement : Ne placez pas les meubles à proximité de sources de feu ou d'objets à haute température pour éviter tout risque d'incendie.

Avertissement : Nettoyez les meubles avec un chiffon humide ou de l'alcool, évitez d'utiliser des produits de nettoyage contenant des produits chimiques corrosifs.

[IT]

Attenzione: leggere attentamente queste istruzioni prima di iniziare il montaggio. Verificare di avere tutti i componenti e gli strumenti elencati nelle pagine. Conservare le istruzioni per riferimento futuro. Alcune parti del montaggio saranno più facili con 2 persone. Se necessario, chiedere assistenza professionale.

Attenzione: posizionare tutte le parti su una superficie piana. Posizionare una coperta morbida o simile sotto per proteggere da graffi o macchie. Evitare di trascinare o far scivolare i componenti sul pavimento.

Attenzione: controllare regolarmente tutti i raccordi e i dispositivi di fissaggio per assicurarsi che siano sicuri e per prevenire incidenti. Se alcune parti sono mancanti, rotte, danneggiate o usurate, interrompere l'uso del prodotto fino a quando non siano state eseguite le riparazioni utilizzando parti autorizzate dalla fabbrica.

Attenzione: non consentire ai bambini di arrampicarsi sui mobili poiché ciò potrebbe causare ribaltamenti e gravi lesioni personali. Montare i mobili lontano dalla portata dei bambini.

Attenzione: non posizionare i mobili vicino a fonti di fuoco o oggetti ad alta temperatura per evitare il rischio di incendio

Attenzione: pulire i mobili con un panno umido o alcol, evitare di utilizzare detersivi contenenti sostanze chimiche corrosive.

[ES]

Advertencia: Lea estas instrucciones completamente antes de comenzar el montaje. Compruebe que tiene todos los componentes y herramientas que se enumeran en las páginas. Conserve las instrucciones para consultarlas más adelante. El montaje de algunas partes será más sencillo con 2 personas. Busque ayuda profesional si es necesario.

Advertencia: Coloque todas las piezas sobre una superficie plana. Coloque una manta suave o algo similar debajo para protegerlas de rayones o manchas. Evite arrastrar o deslizar los componentes por el piso.

Advertencia: Verifique regularmente todos los accesorios y fijaciones para asegurarse de que estén seguros y evitar accidentes. Si falta alguna pieza, está rota, dañada o desgastada, deje de usar el producto hasta que se hayan realizado las reparaciones con piezas autorizadas de fábrica.

Advertencia: No permita que los niños se suban a los muebles, ya que esto puede provocar que se vuelquen y lesiones personales graves. Monte los muebles fuera del alcance de los niños.

Advertencia: No coloque los muebles cerca de fuentes de fuego u objetos de alta temperatura para evitar el riesgo de incendio.

Advertencia: Limpie los muebles con un paño húmedo o alcohol, evite usar agentes de limpieza que contengan químicos corrosivos.

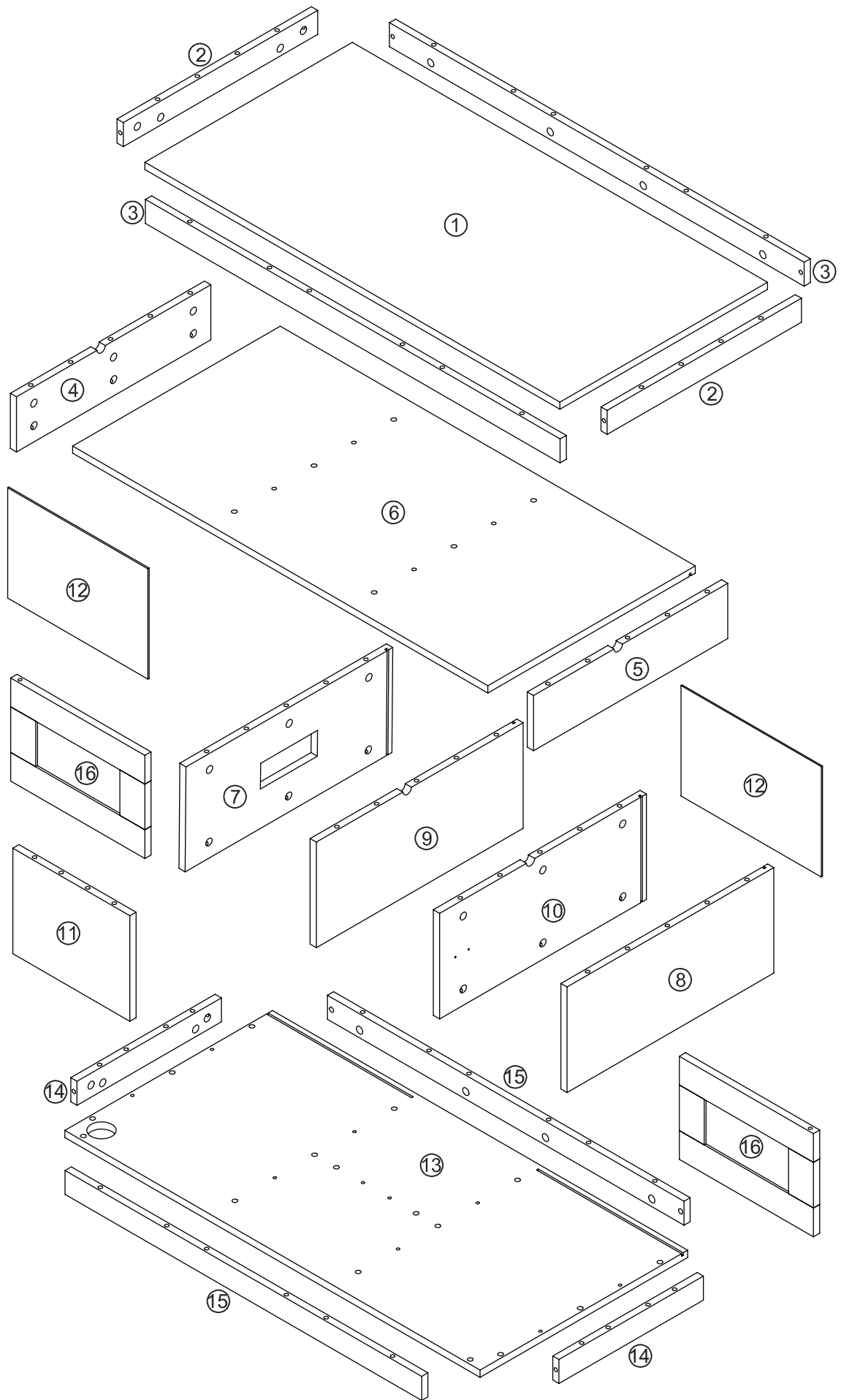

DE:Teilleiste für / EN:Parts List for / FR:Liste des pièces pour / IT:Elenco delle parti per / ES:Lista de piezas para
N892P417192W/N892P417192B

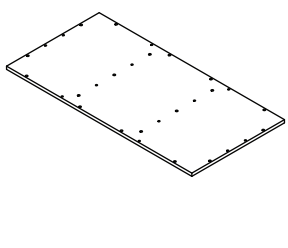
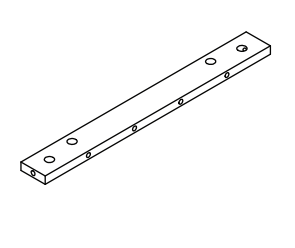
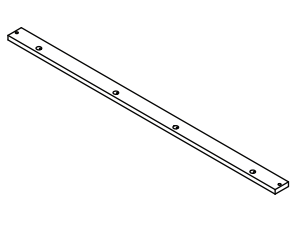
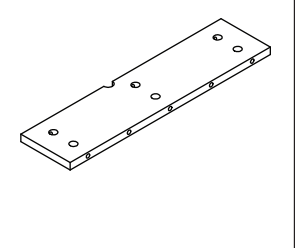
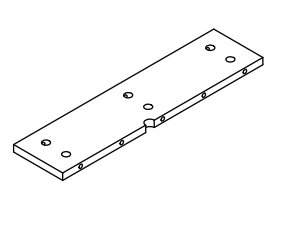
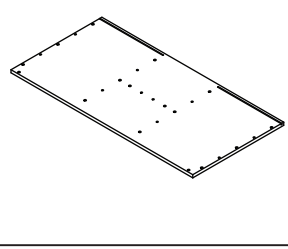
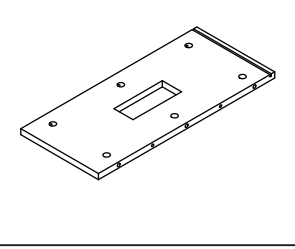
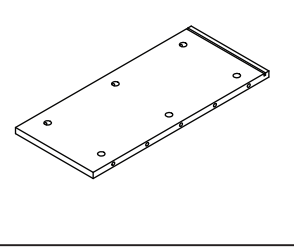
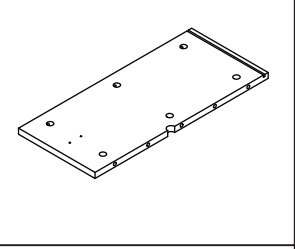
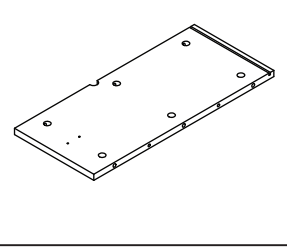
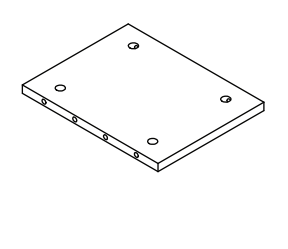
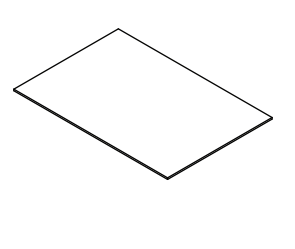
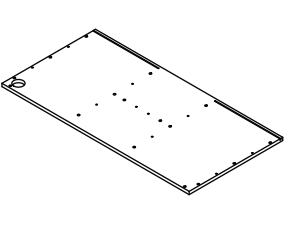
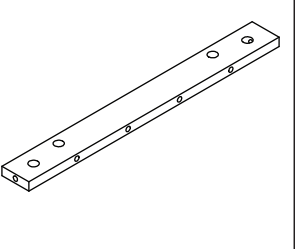
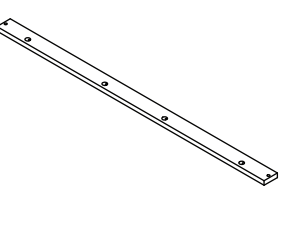
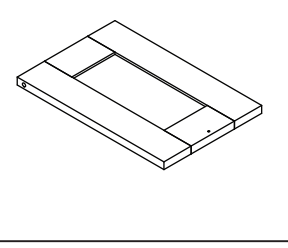
				
① x1	② x2	③ x2	④ x1	⑤ x1
				
⑥ x1	⑦ x1	⑧ x1	⑨ x1	⑩ x1
				
⑪ x1	⑫ x2	⑬ x1	⑭ x2	⑮ x2
				
⑯ x2				

A x72



40 mm

B x72



15*9 mm

C x44

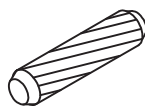

8*40 mm

D x6



3.5*14 mm

E x4

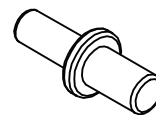

F x2



900mm

G x1

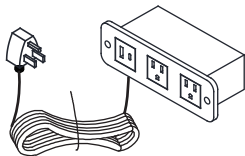

H x72



J x2

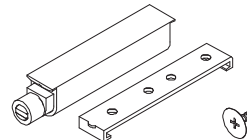

K x5



L x1

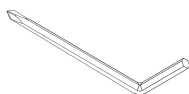

EN:If you find that the white glue particles on the board are missing, please press part K into the board.
 DE:Sollten Sie feststellen, dass die weißen Gummipartikel auf der Platine fehlen, drücken Sie bitte Teil K in die Platine.
 FR:Si vous constatez qu'il manque des particules de caoutchouc blanc sur le tableau, veuillez enfoncer la partie K dans le tableau.
 IT:Se trovi che mancano le particelle di gomma bianca sulla tavola, premi la parte K sulla tavola.
 ES:Si descubre que faltan las partículas de goma blancas en el tablero, presione la parte K en el tablero.

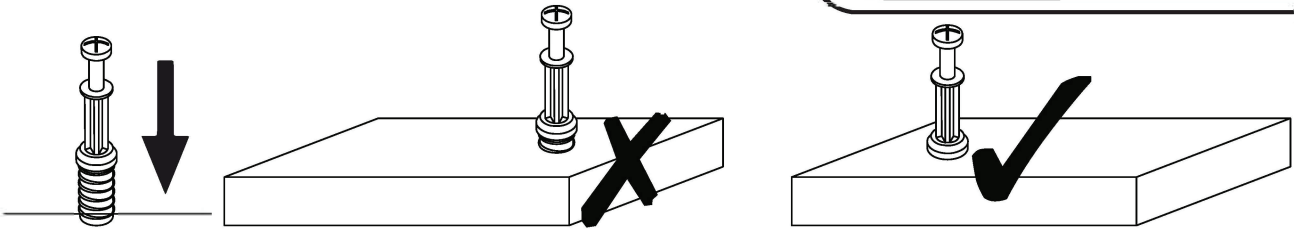

EN_QUICKFIT: Tighten quickfit until shoulder is flush with panel. Do not overtighten or undertighten.

FR_RACCORD RAPIDE: Faites serrer le raccord rapide jusqu'à ce que l'épaule soit parfaitement encastré dans le panneau. Il ne faut ni trop serrer ni insuffisamment serrer.

ES_QUICKFIT: Apriete quickfit hasta que el hombro se descargue con el panel. NO lo sobreapriete ni lo apriete poco.

DE_QUICKFIT: Ziehen Sie den Quickfit fest, bis die Schulter mit der Platte bündig ist. Bitte nicht zu fest oder zu schwach anziehen.

IT_MONTAGGIO RAPIDO: Stringere il montaggio rapido fino a quando la spalla è a filo con il pannello, non stringere troppo o troppo poco.

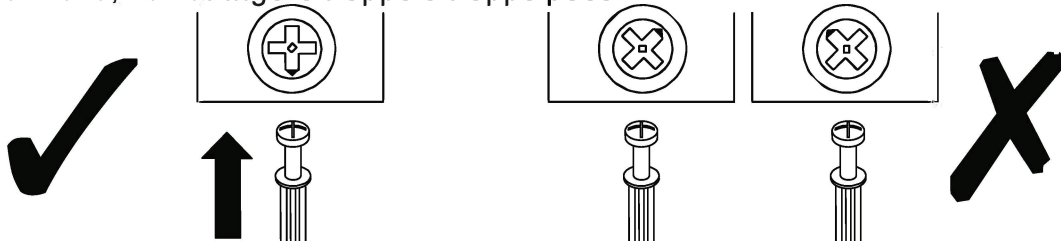

EN_CAM LOCK: When fitting cam lock, ensure starting position is correct before you insert connecting quickfit.

FR_SERRURE BATTEUSE: Avant d'insérer la serrure batteuse, veillez à la bonne orientation avant d'insérer le raccord rapide.

ES_CIERRE DE LA CÁMARA: Cuando instale el cierre de la cámara, asegúrese de que la posición de inicio es correcta antes de que inserte el quickfit conector.

DE_CAM-LOCK: Achten Sie bei der Montage des Cam-Locks auf die richtige Ausgangsposition, bevor Sie den Quickfit einsetzen.

IT_BLOCCAGGIO A CAMMA: Quando si monta il bloccaggio a camma, assicurarsi che la posizione iniziale sia corretta prima di inserire il montaggio rapido di collegamento.

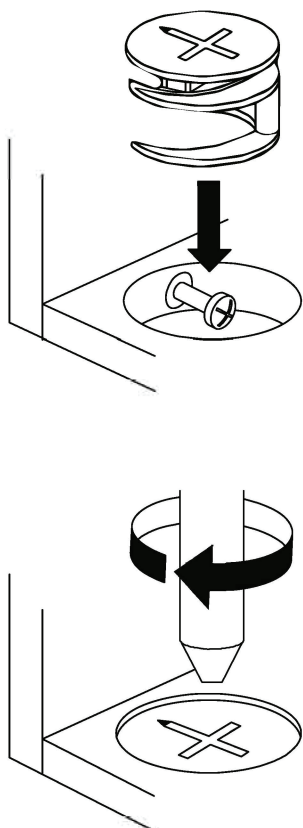

EN_Quickfit head should be in the centre of the cam lock when the two panels are joined.

Cam lock should be inserted before quickfit.

FR_Lorsque les deux panneaux sont assemblés, la tête du raccord rapide doit reposer au centre de la serrure batteuse. Il faut insérer la serrure batteuse avant le raccord rapide.

ES_El cabezal del quickfit debe estar en el centro del cierre de la cámara cuando se unan los dos paneles.

Se debe insertar el cierre de la cámara antes que el quickfit.

DE_Der Quickfit-Kopf sollte sich in der Mitte des Cam-Locks befinden, wenn die beiden Platten zusammengefügt sind.

Der Cam-Lock sollte vor dem Quickfit eingesetzt werden.

IT_La testa del montaggio rapido deve trovarsi al centro del bloccaggio a camma quando i due pannelli sono uniti.

Il Bloccaggio a Camma deve essere inserito prima del montaggio rapido.

EN_Turn cam lock clockwise to tighten.



FR_Faites tourner la serrure batteuse dans le sens des aiguilles d'une montre pour la resserrer.

ES_Gire el cierre de la cámara en sentido horario para apretarlo.

DE_Drehen Sie den Cam-Lock im Uhrzeigersinn, um ihn festzuziehen.

IT_Ruotare il bloccaggio a camma in senso orario per stringere.

1

A x16  40 mm	C x8  8*40 mm
--	---

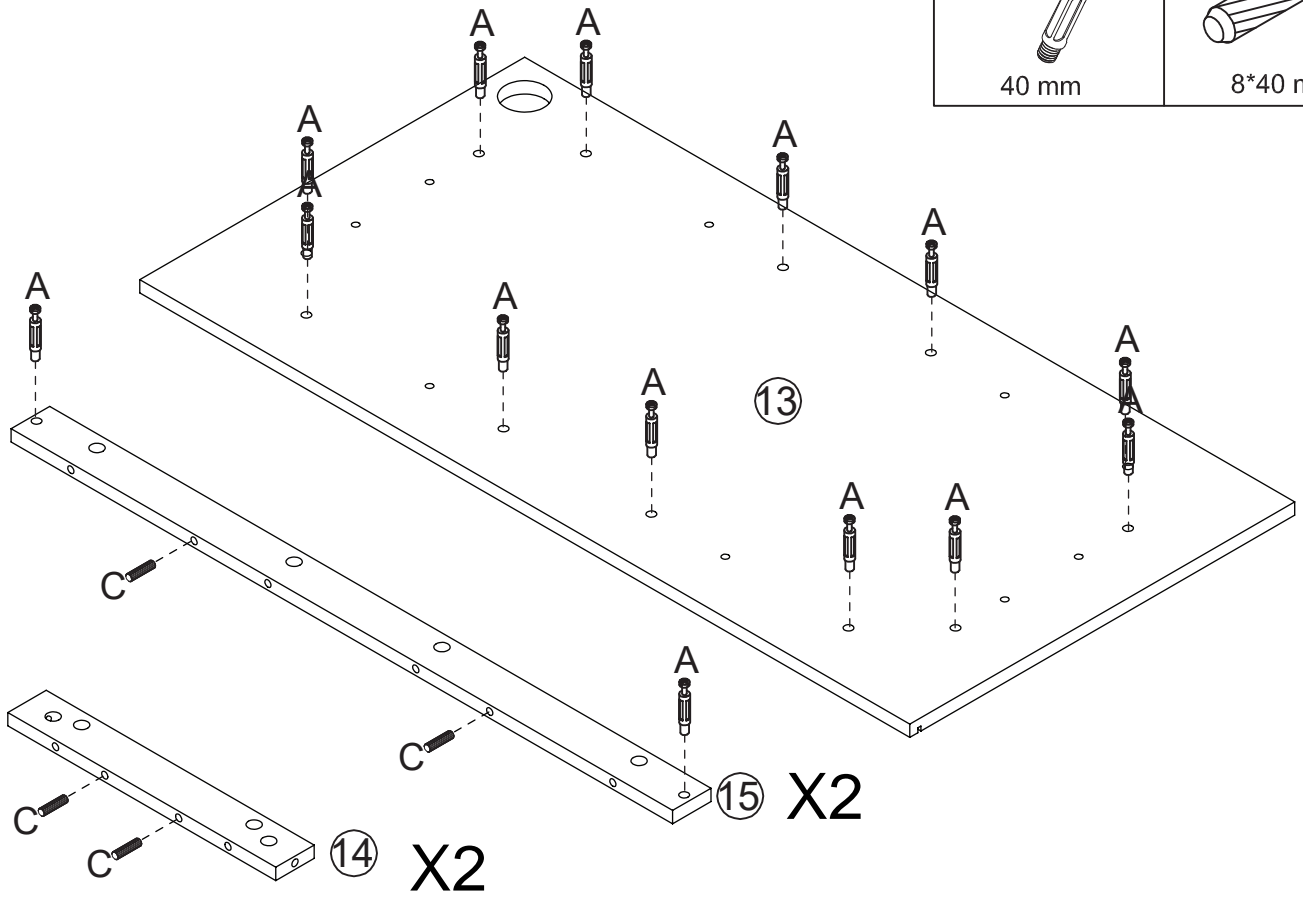

2

B x4  15*9 mm

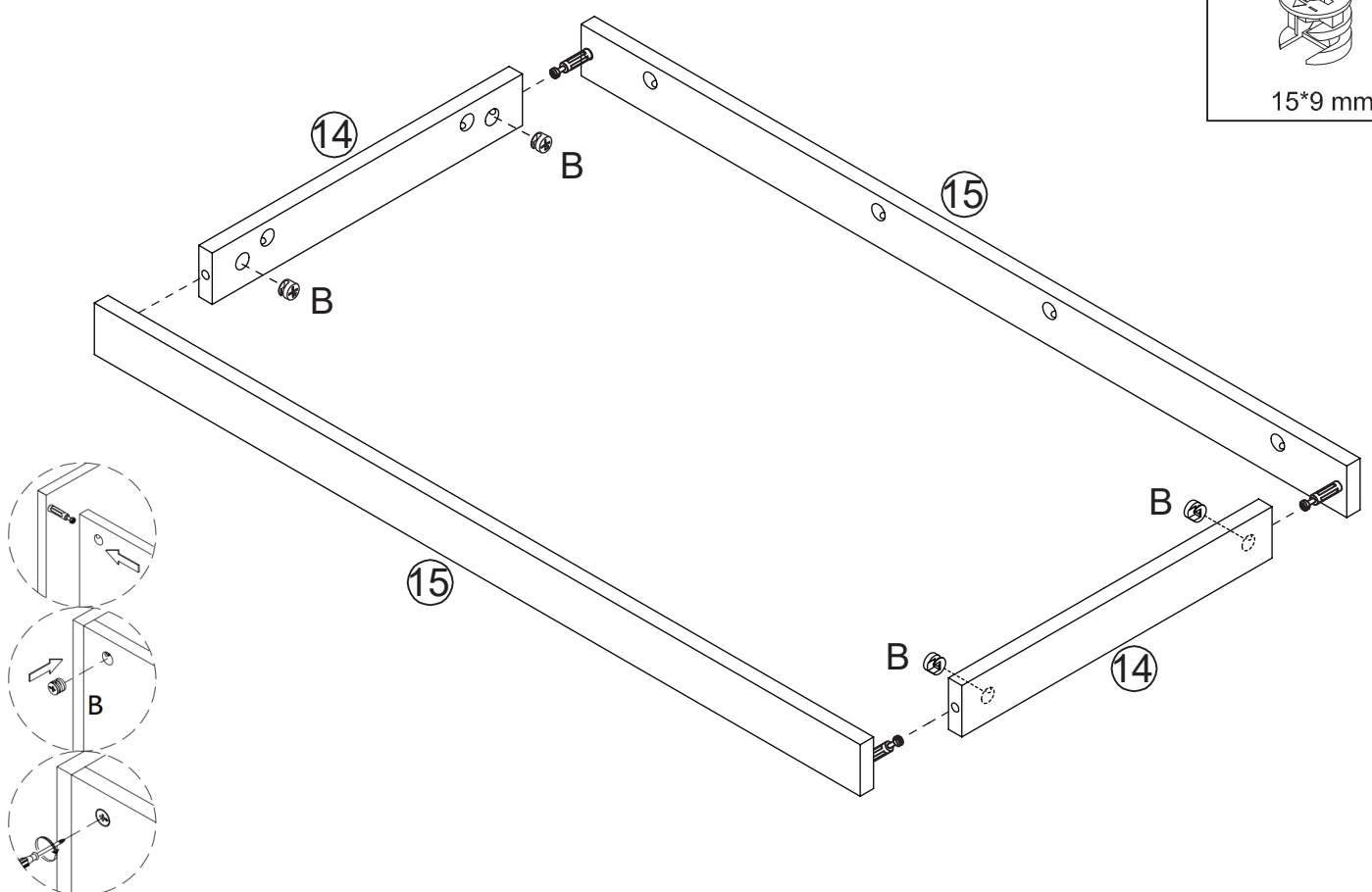

3

B x12



15*9 mm

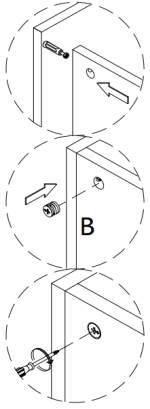
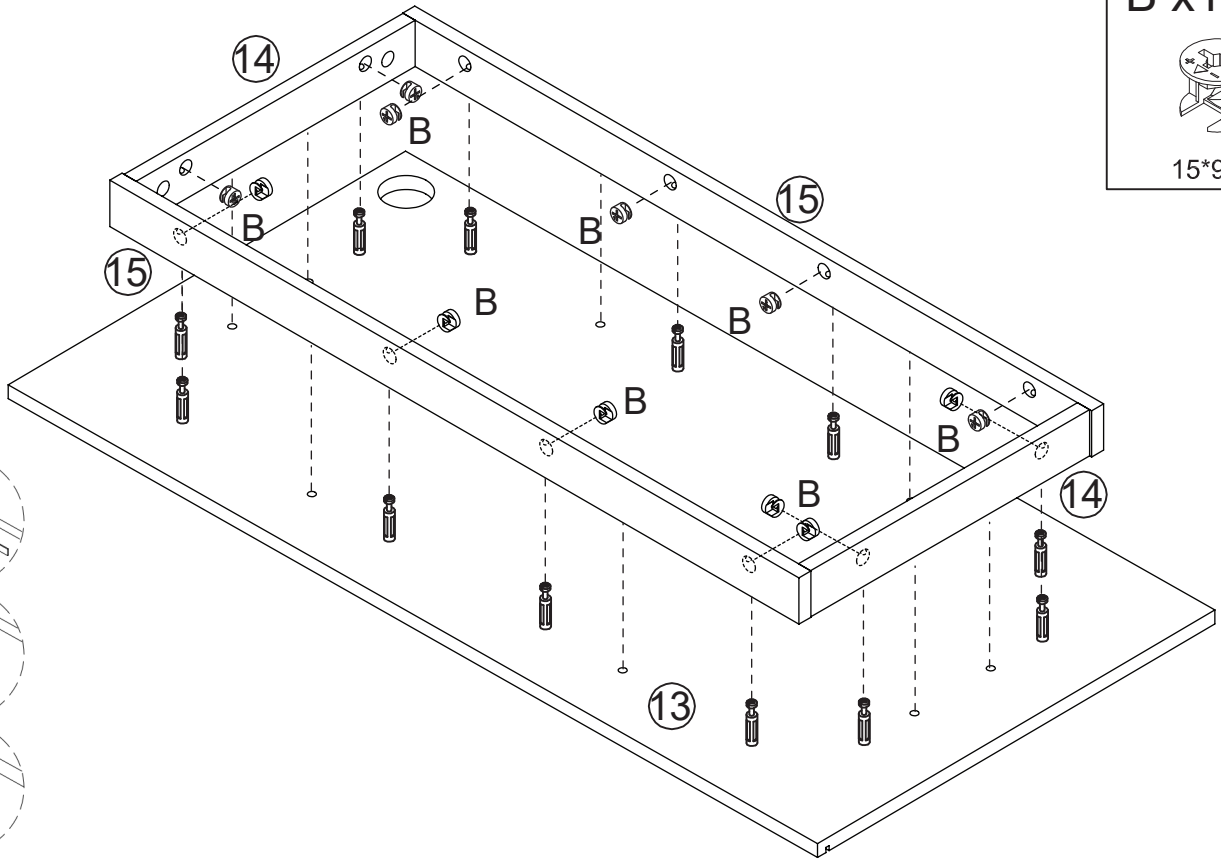

4

A x14



40 mm

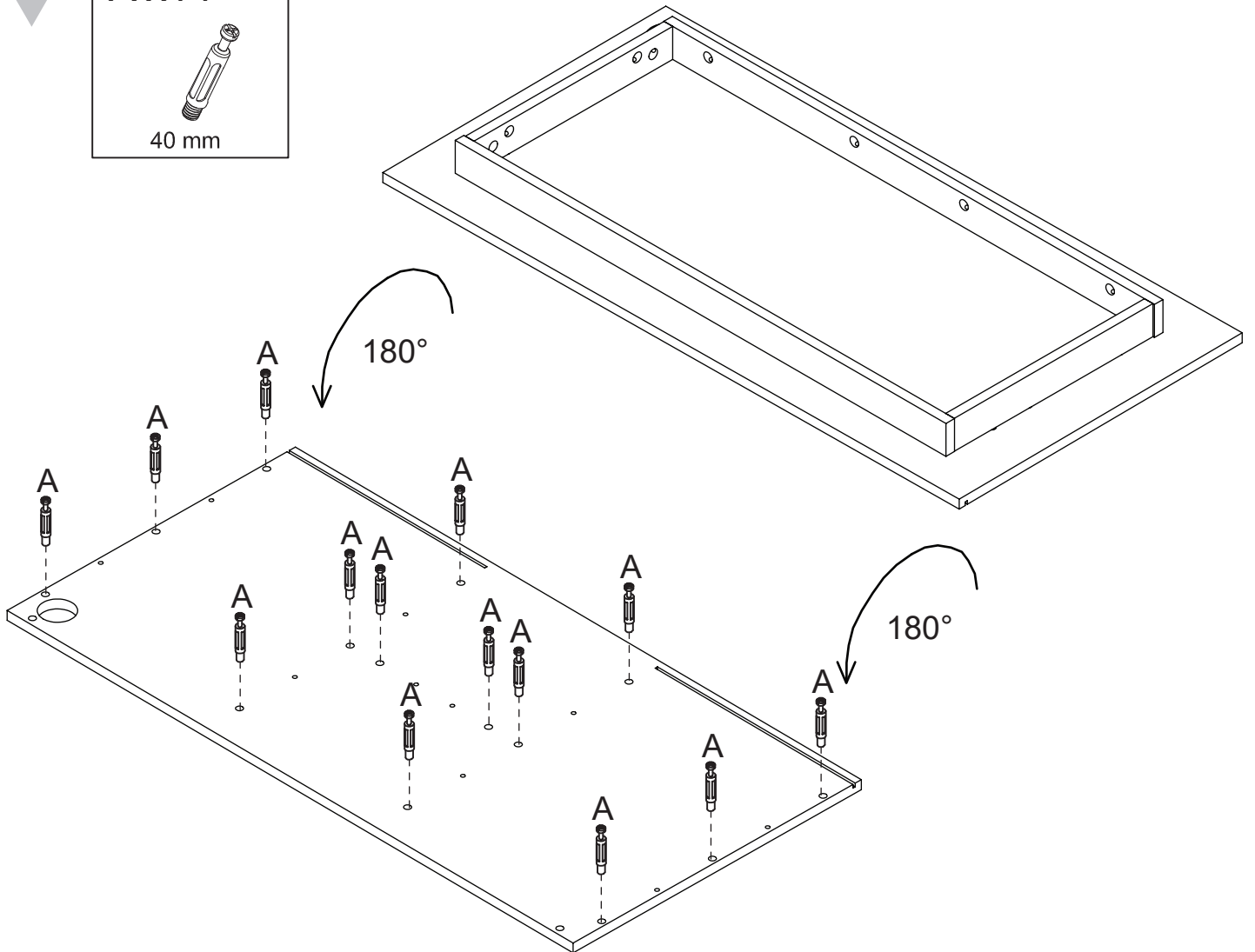

5

C x12

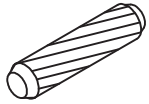

8*40 mm

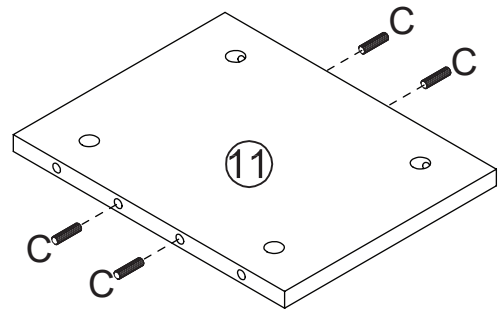
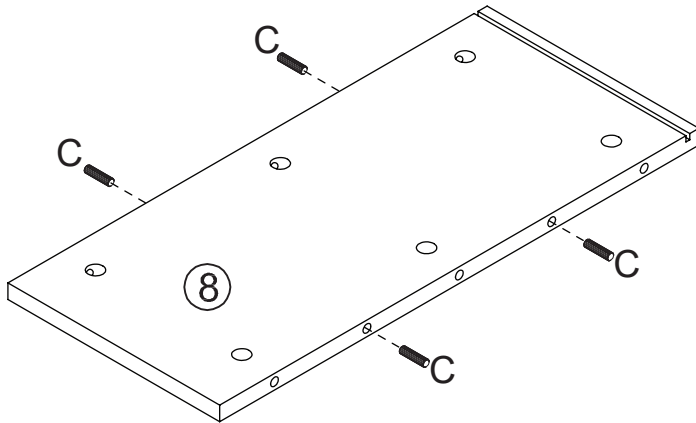
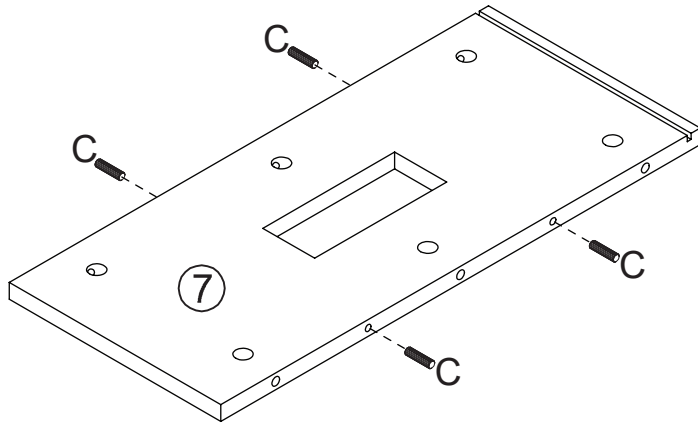

6

D x4



3,5*14 mm

J x2

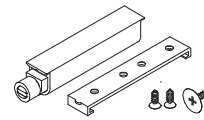

C x8

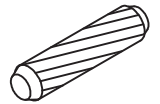

8*40 mm

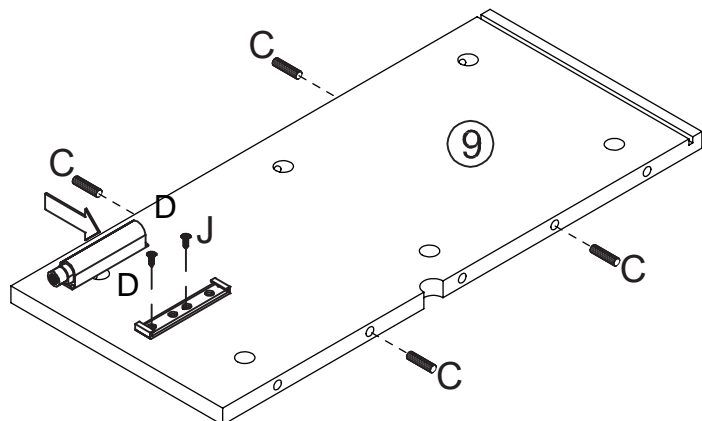
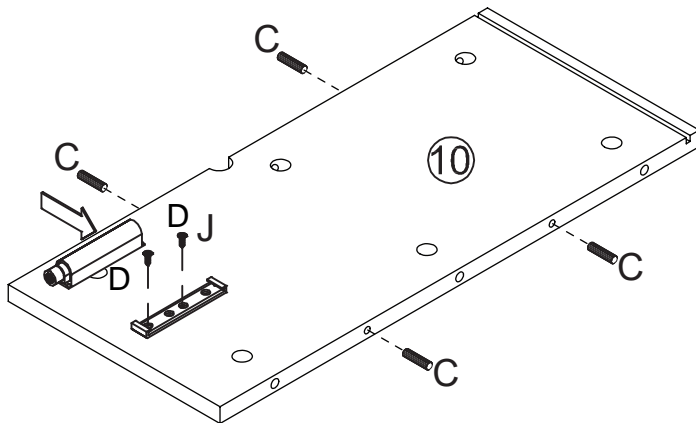

7

B x12

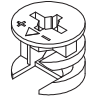

15*9 mm

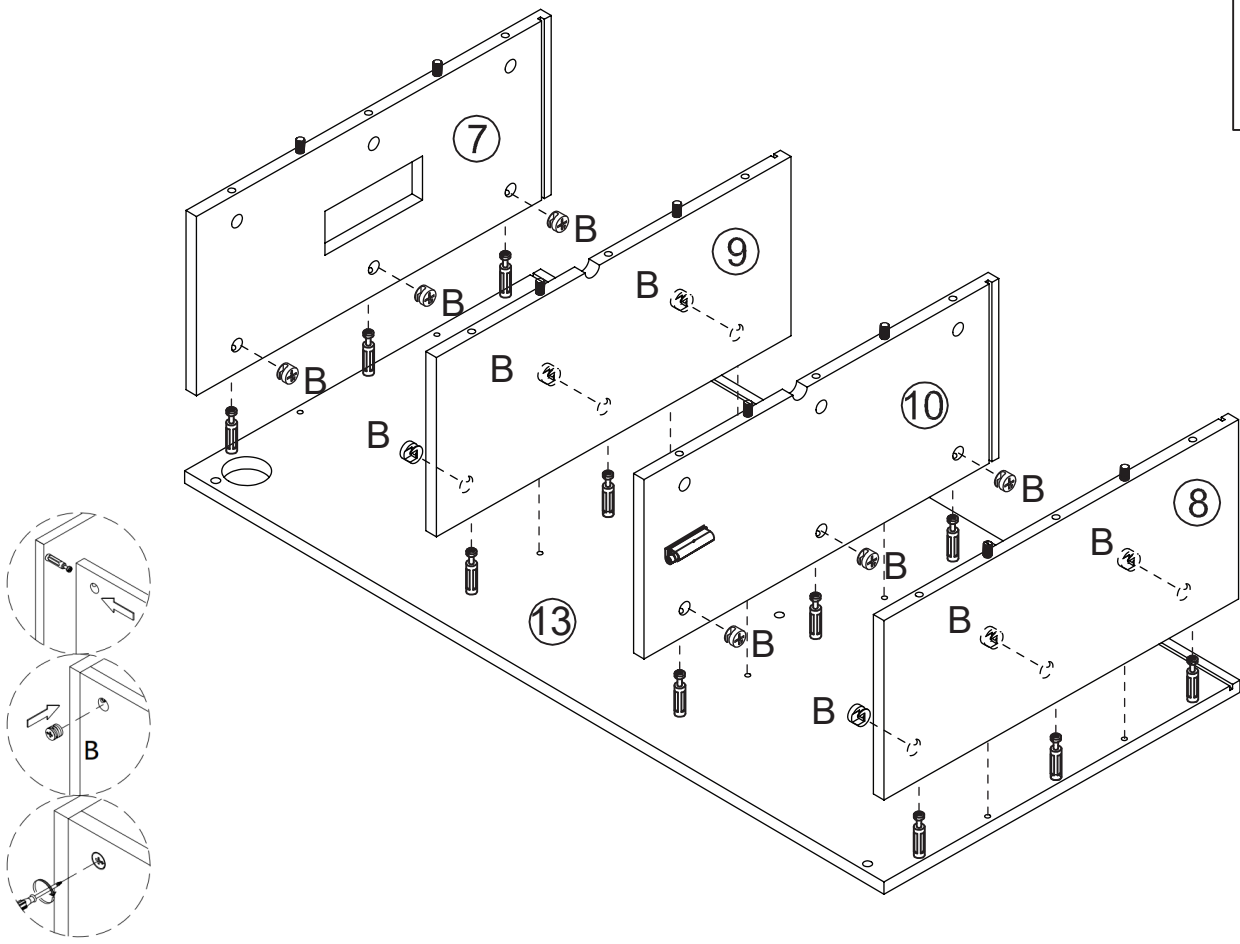

8

B x2



15*9 mm

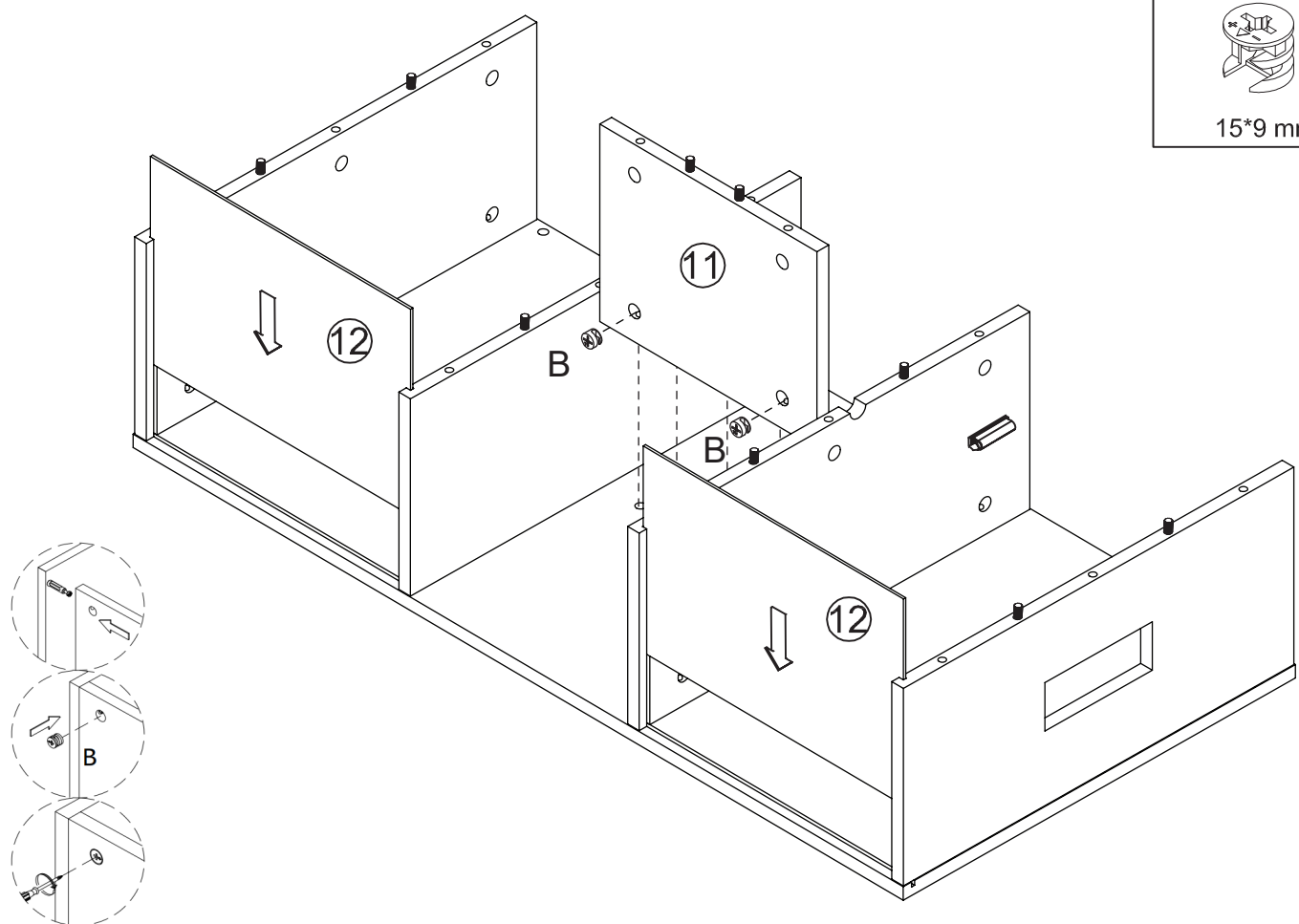

9

D x2



3.5*14 mm

G x1

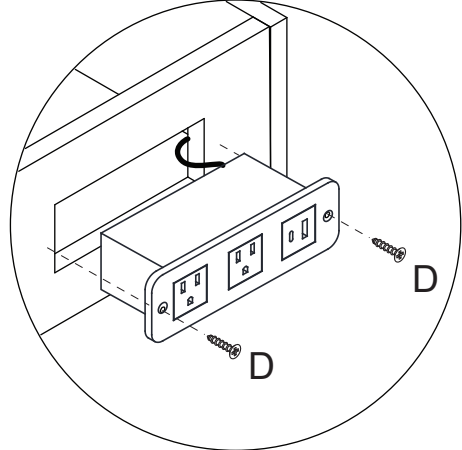
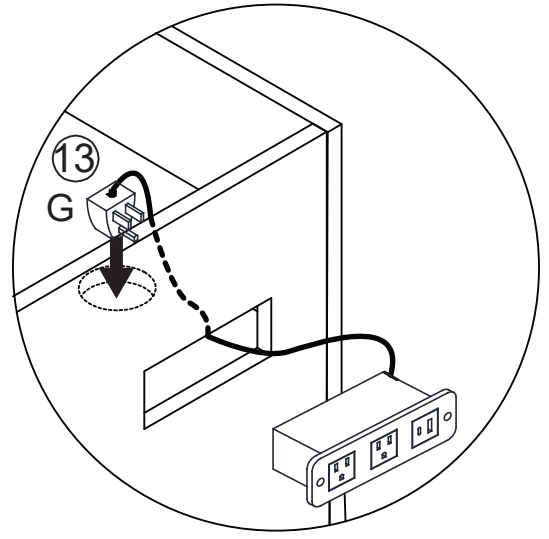
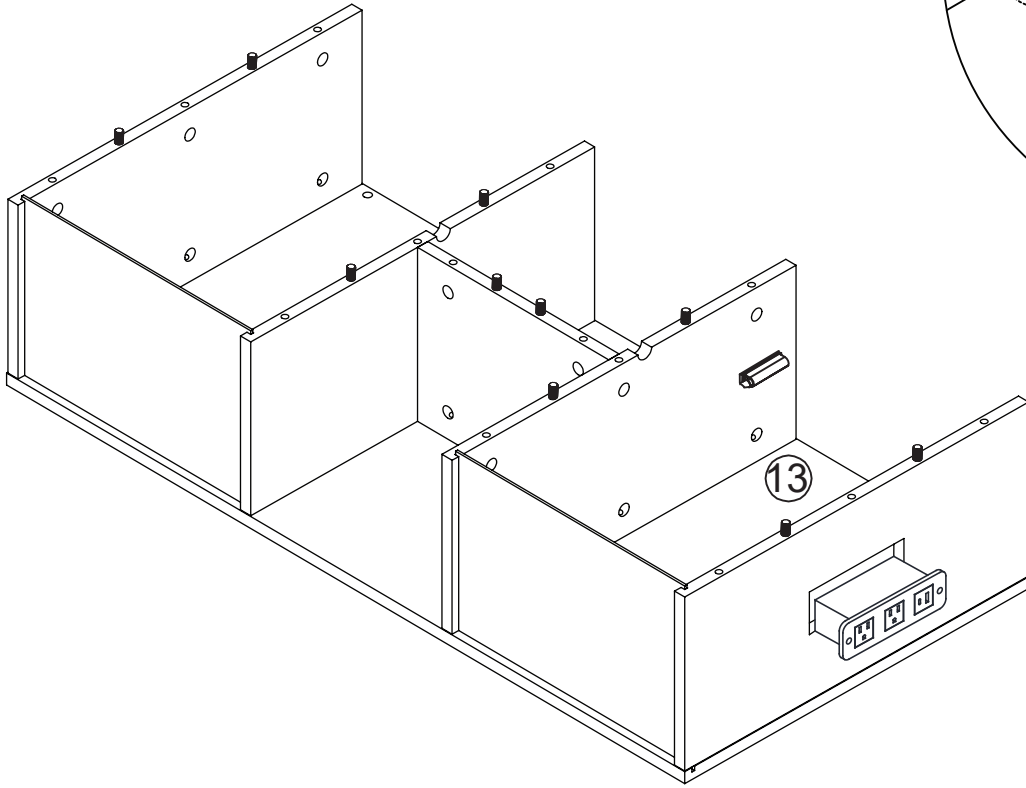
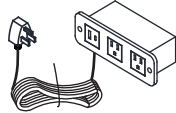

10

A x14



40 mm

C x8

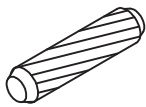

8*40 mm

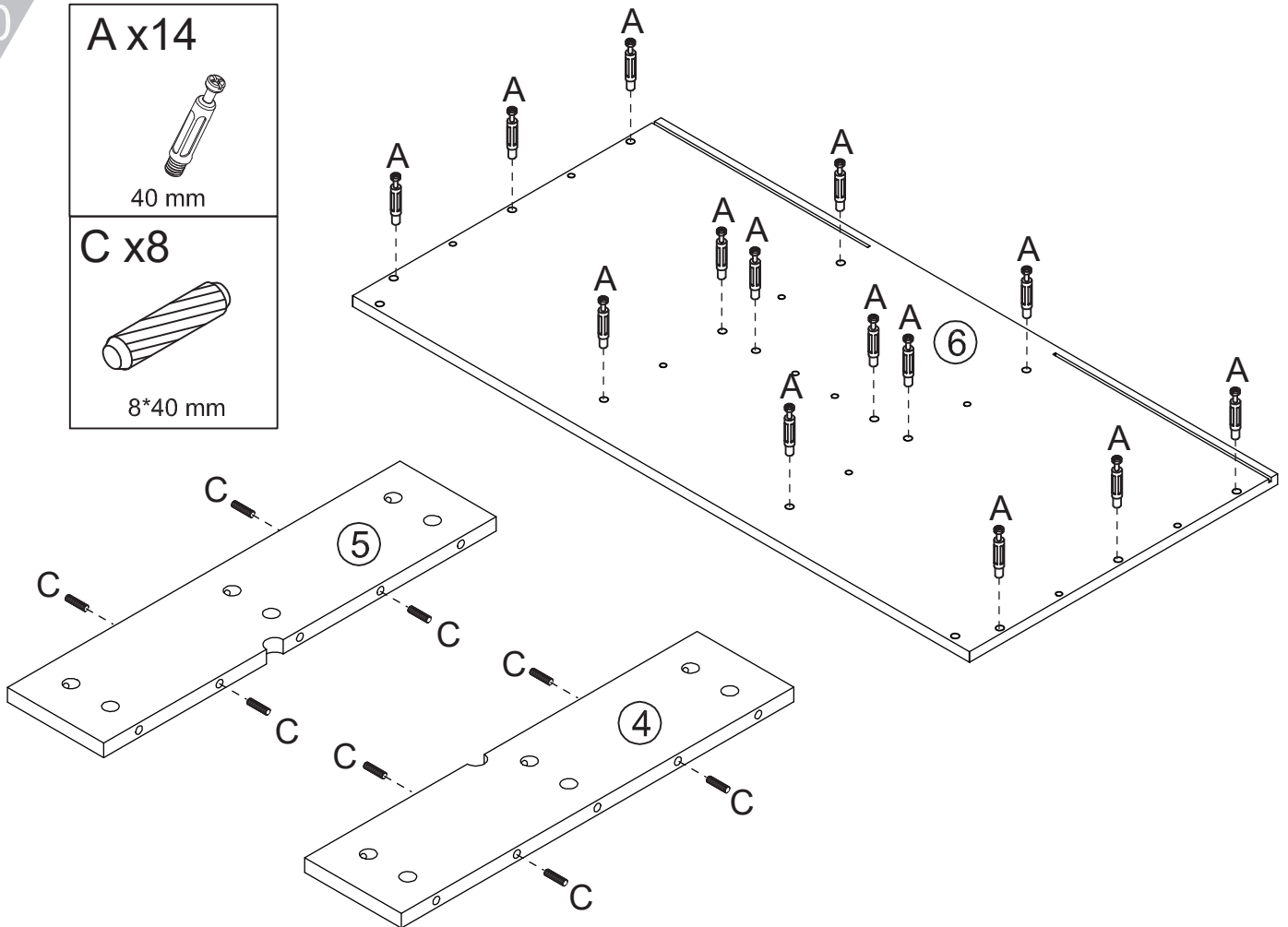

11

B x14



15*9 mm

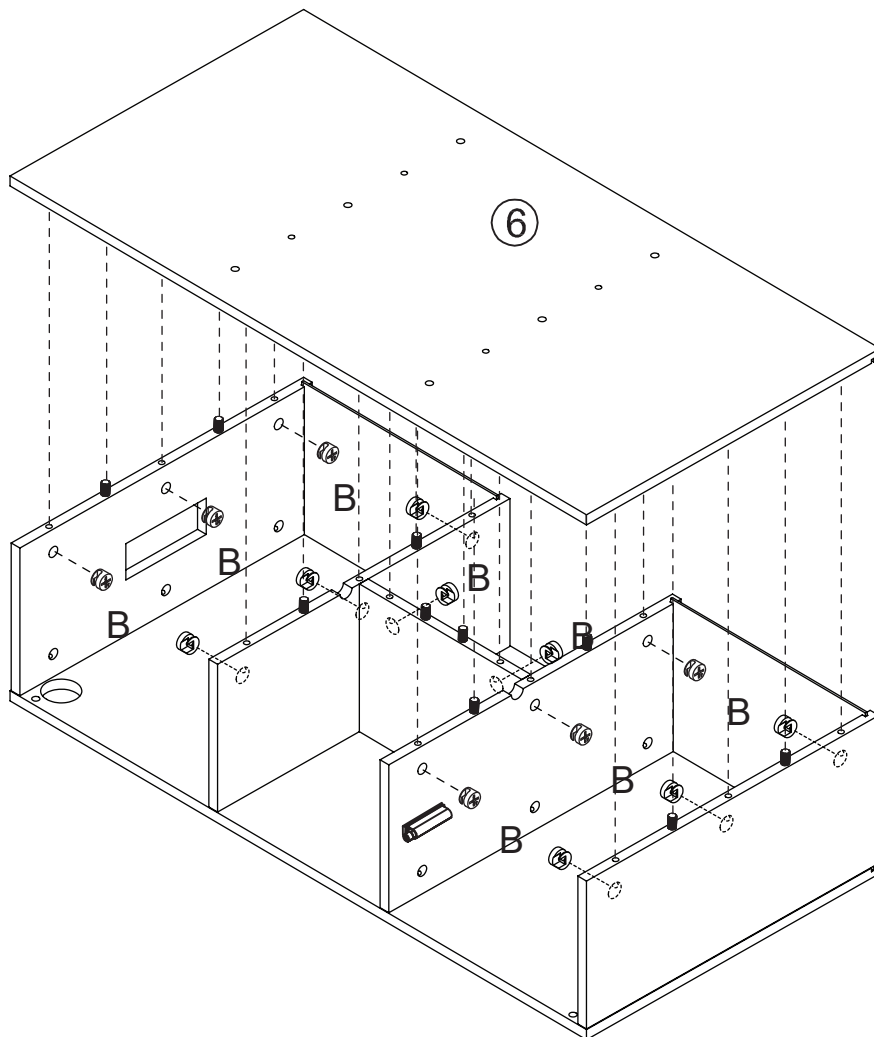
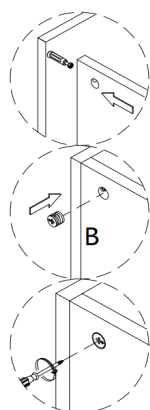

12

F x1



900mm

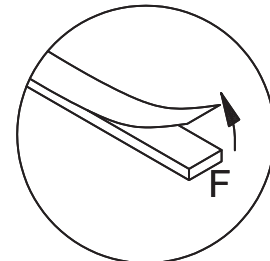
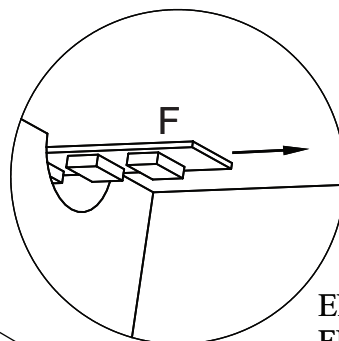

EN: Tear off the back tape
 FR: Déchirer le ruban adhésif
 arrière
 DE: Reiß das hintere Band ab
 IT: Rimuovere il nastro
 posteriore
 ES: Arrancar la cinta trasera

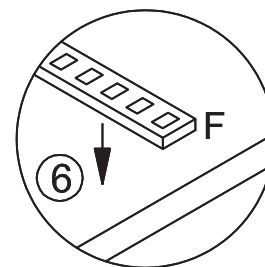
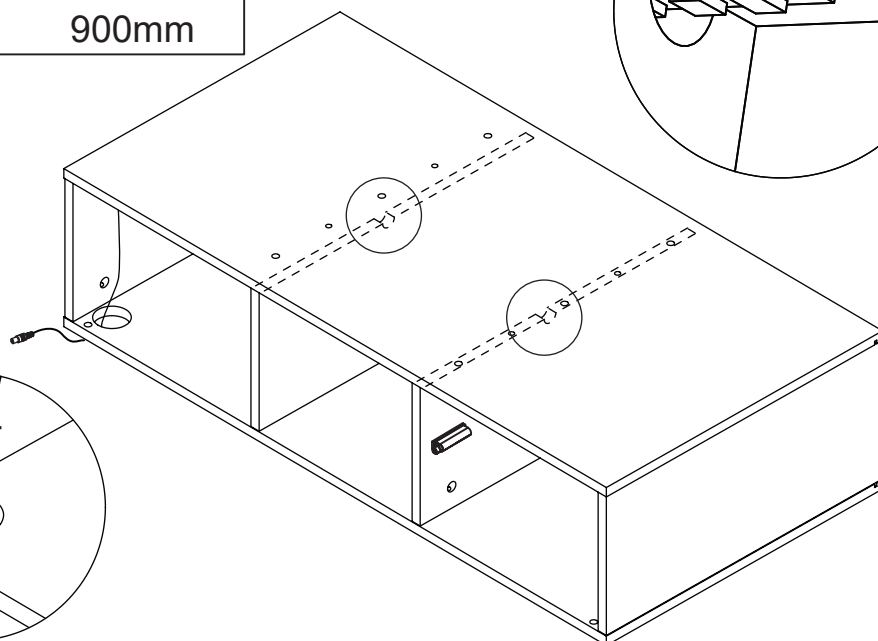
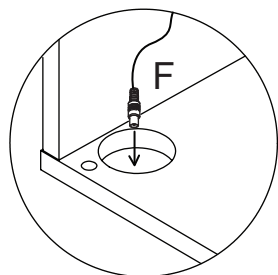

DE: Scannen Sie den QR-Code, um die App zur Steuerung des LED-Lichts herunterzuladen.
 EN: Scan the QR code to download the app to control the LED light.
 IT: Scansiona il codice QR per scaricare l'app per controllare la luce LED.
 FR: Scannez le code QR pour télécharger l'application afin de contrôler la lumière LED.
 ES: Escanea el código QR para descargar la aplicación y controlar la luz LED.

13

A x6

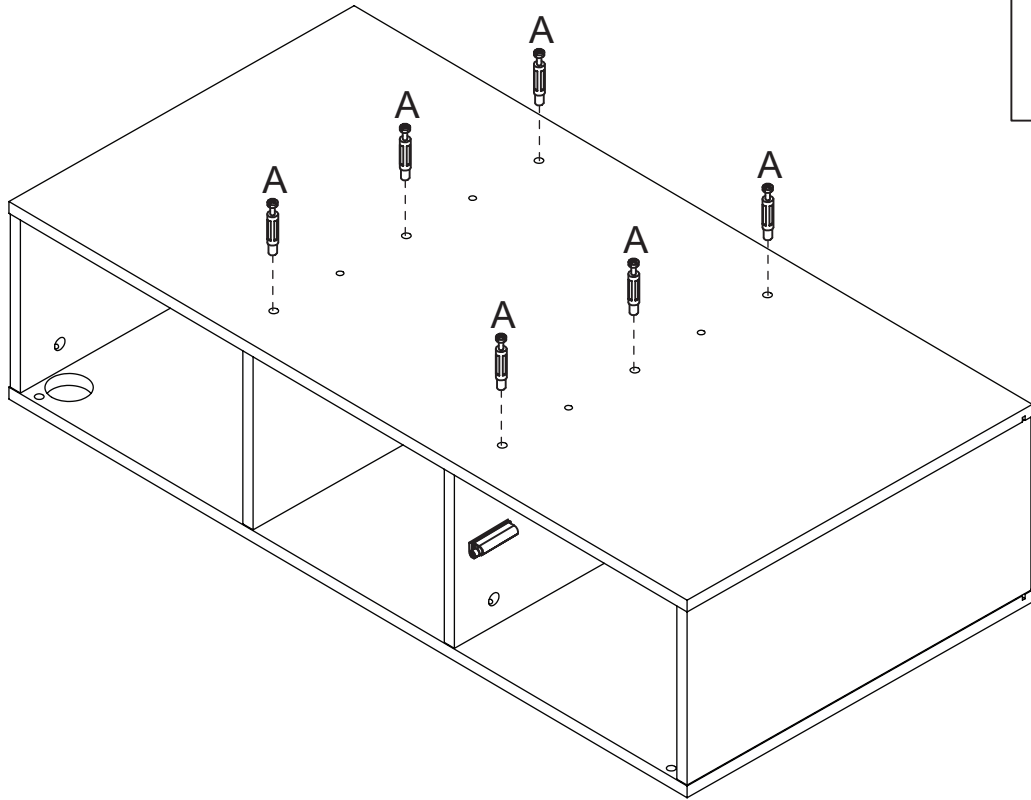

14

B x6

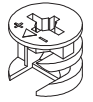

15*9 mm

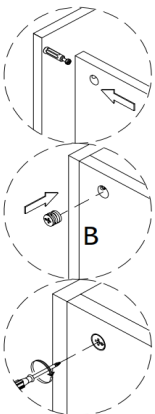
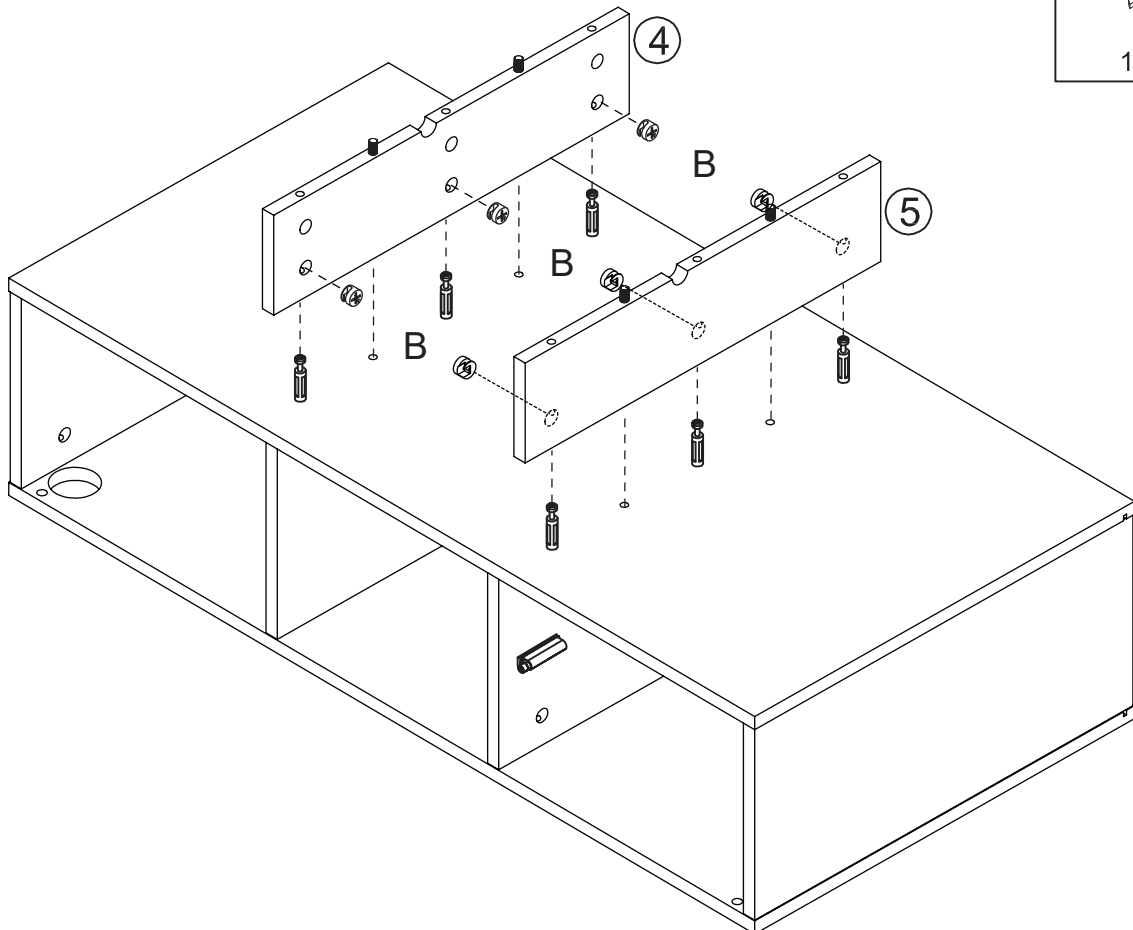

15

A x22

C x8

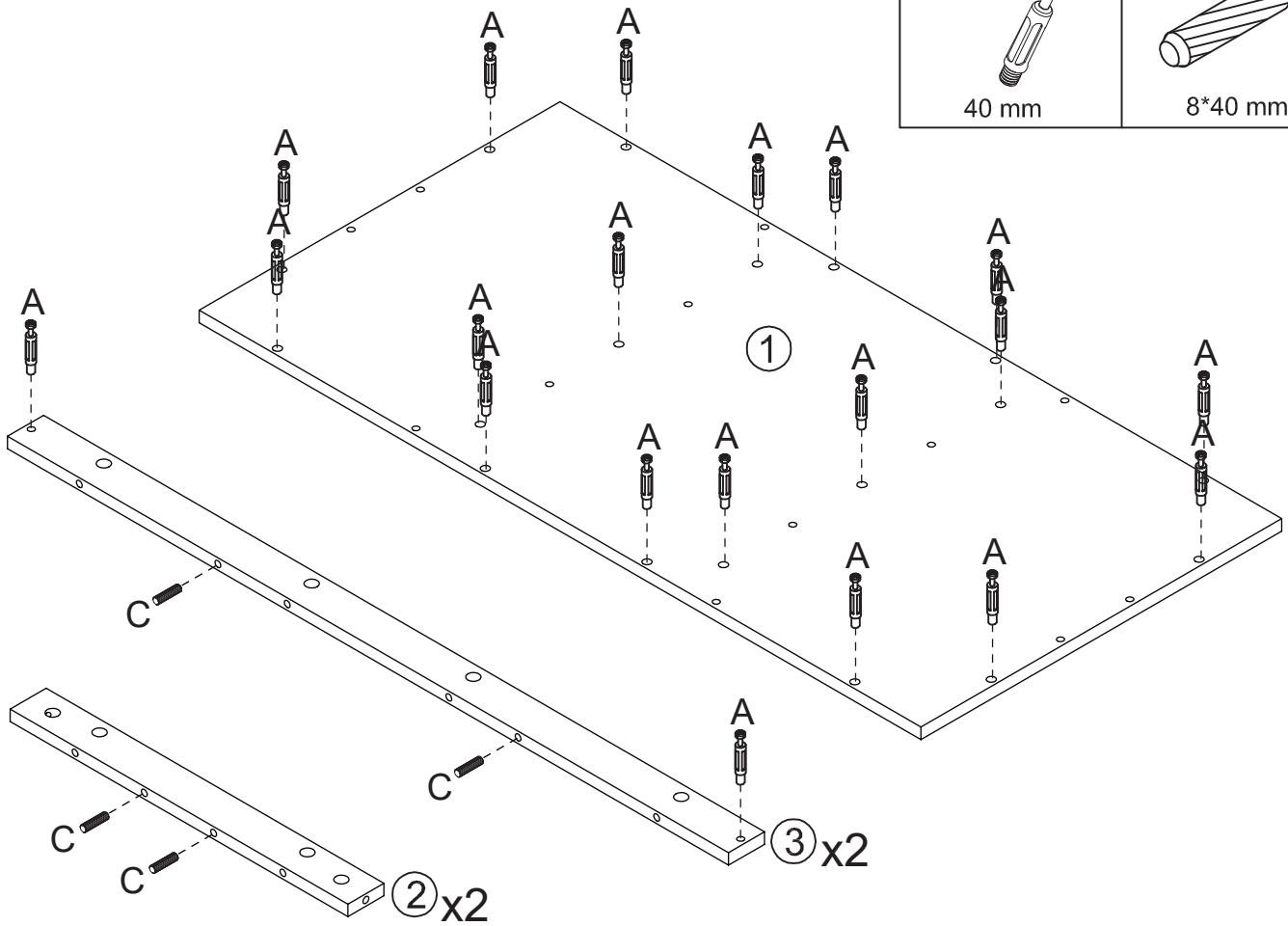
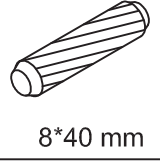

16

B x4

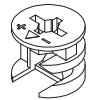

15*9 mm

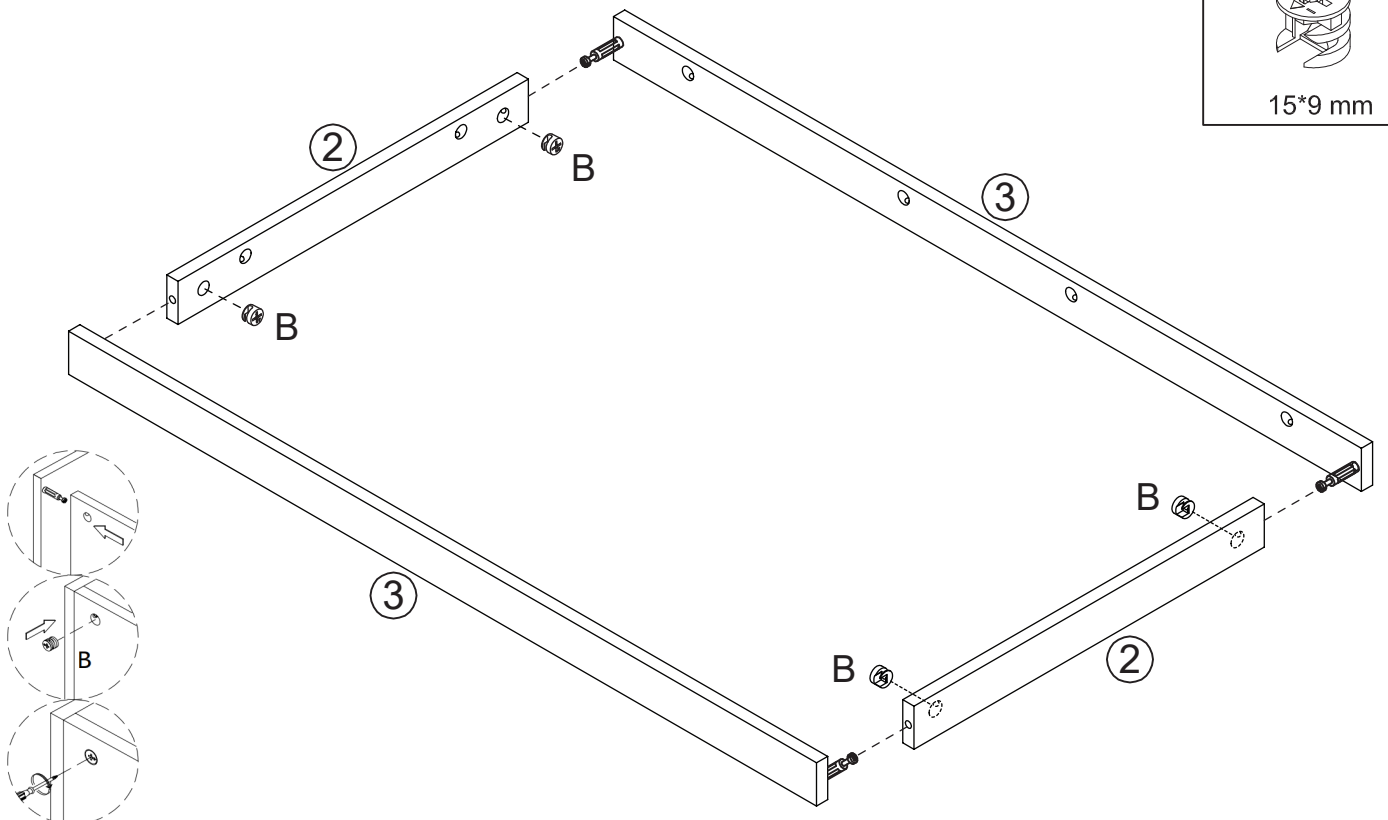

17

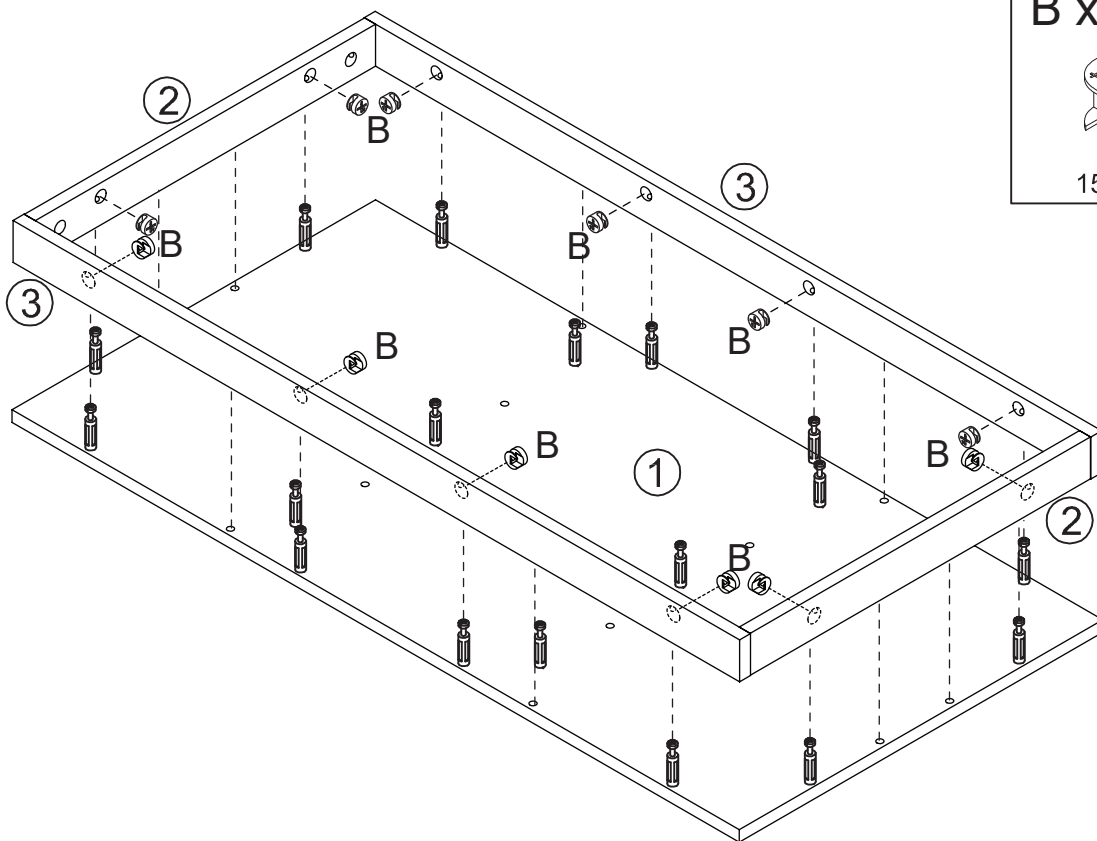

B x12



15*9 mm

18

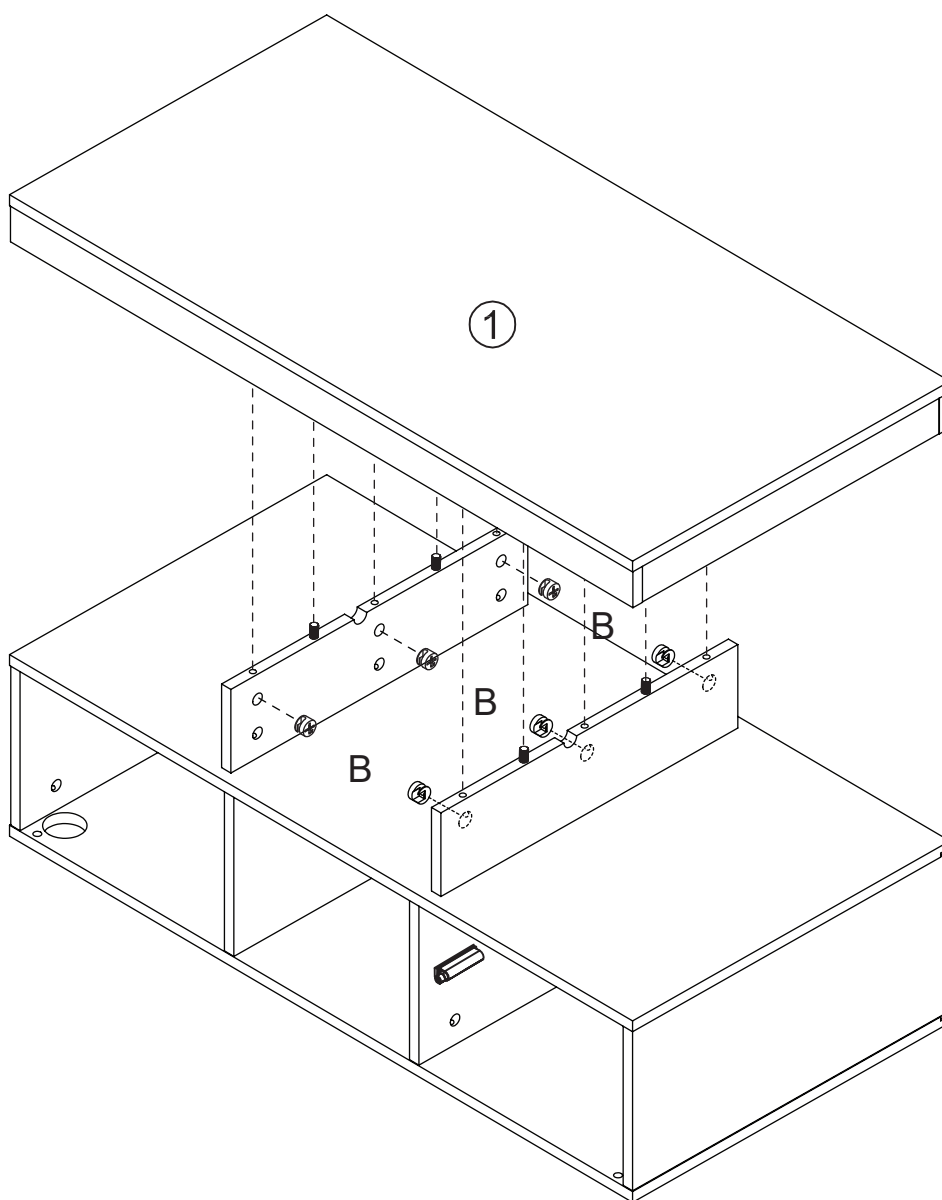

B x6



15*9 mm

19

F x1



900mm

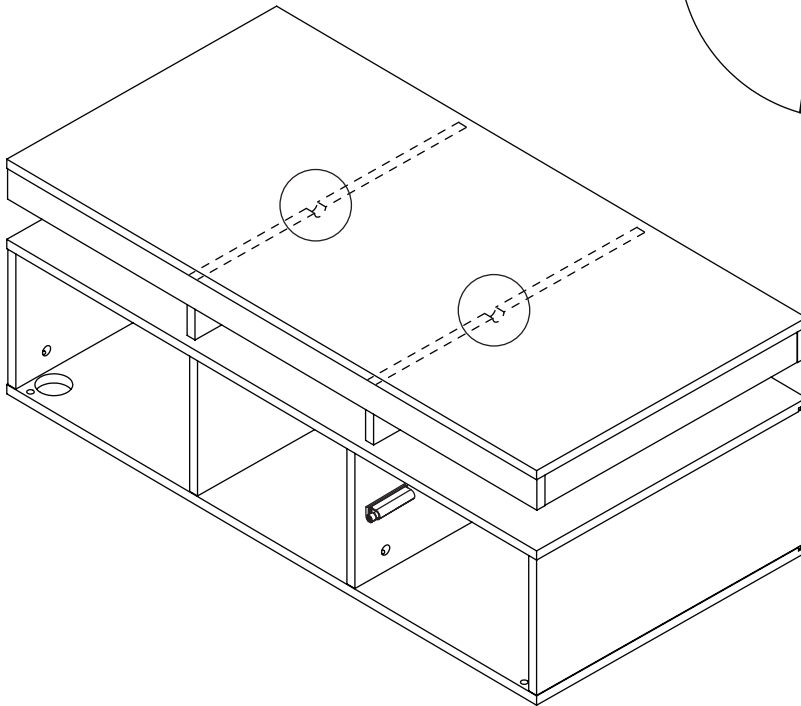
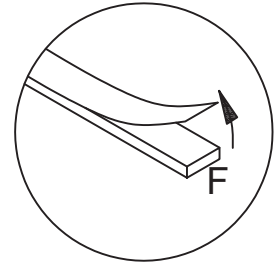
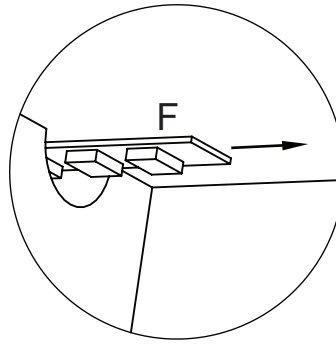

EN:Tear off the back tape
 FR:Déchirer le ruban adhésif
 arrière
 DE:Reiß das hintere Band ab
 IT: Rimuovere il nastro
 posteriore
 ES:Arrancar la cinta trasera

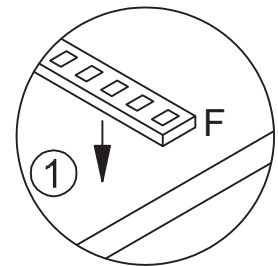

DE:Scannen Sie den QR-Code, um die App zur Steuerung des LED-Lichts herunterzuladen.

EN:Scan the QR code to download the app to control the LED light.

IT:Scansiona il codice QR per scaricare l'app per controllare la luce LED.

FR:Scannez le code QR pour télécharger l'application afin de contrôler la lumière LED.

ES:Escanea el código QR para descargar la aplicación y controlar la luz LED.

20

x2

J x2

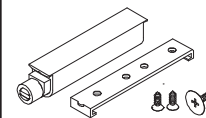

E x4

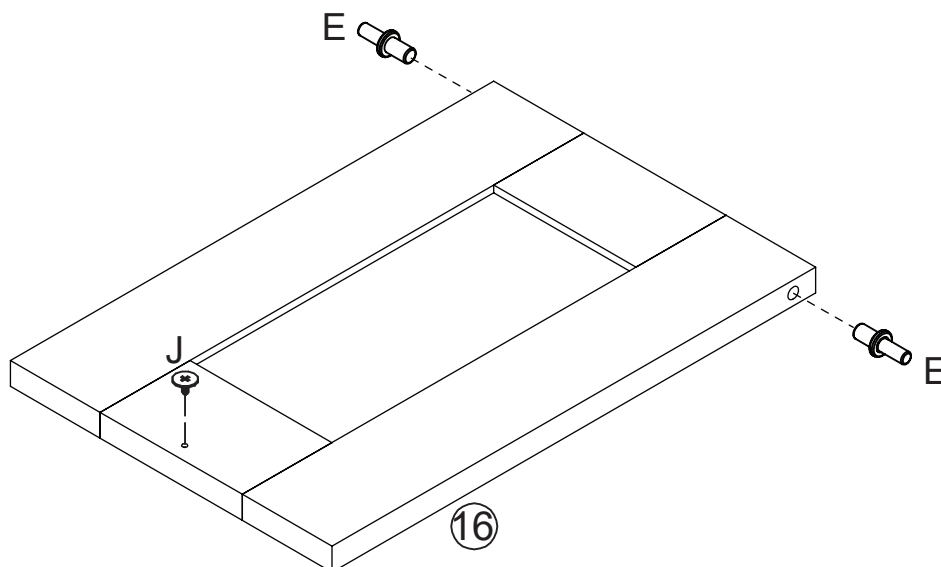
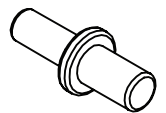

21

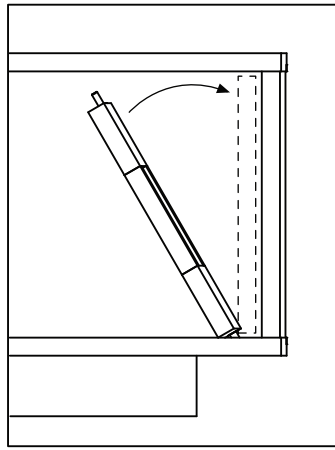
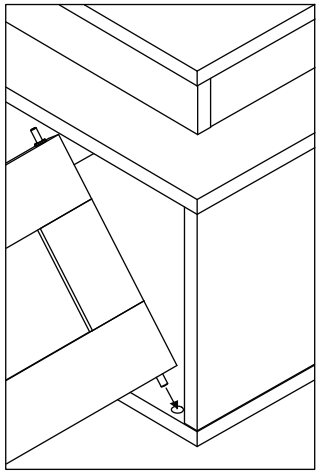
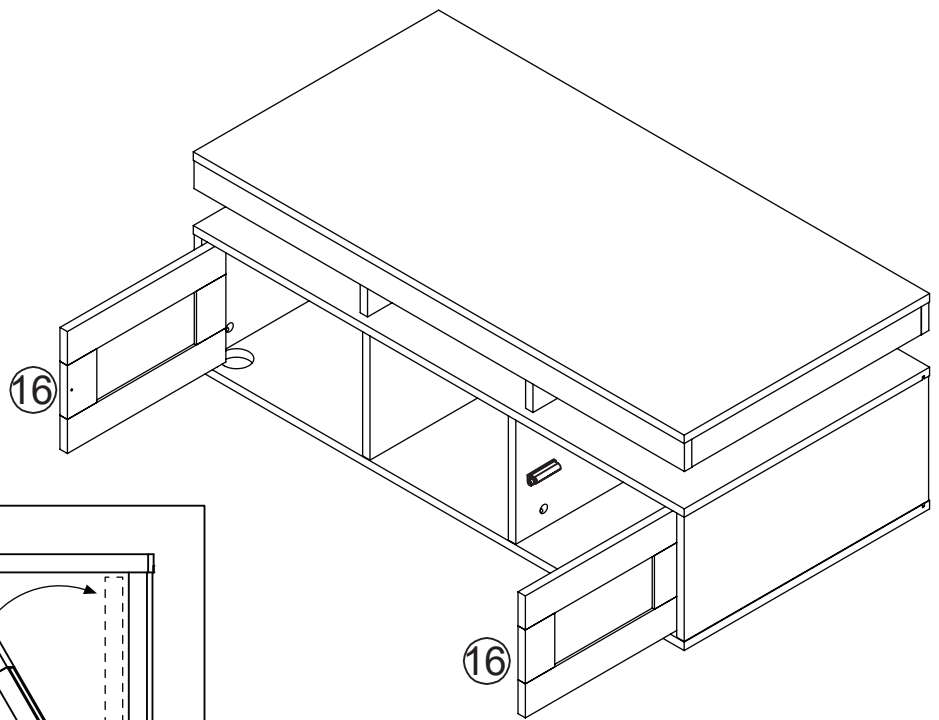

22

H x72

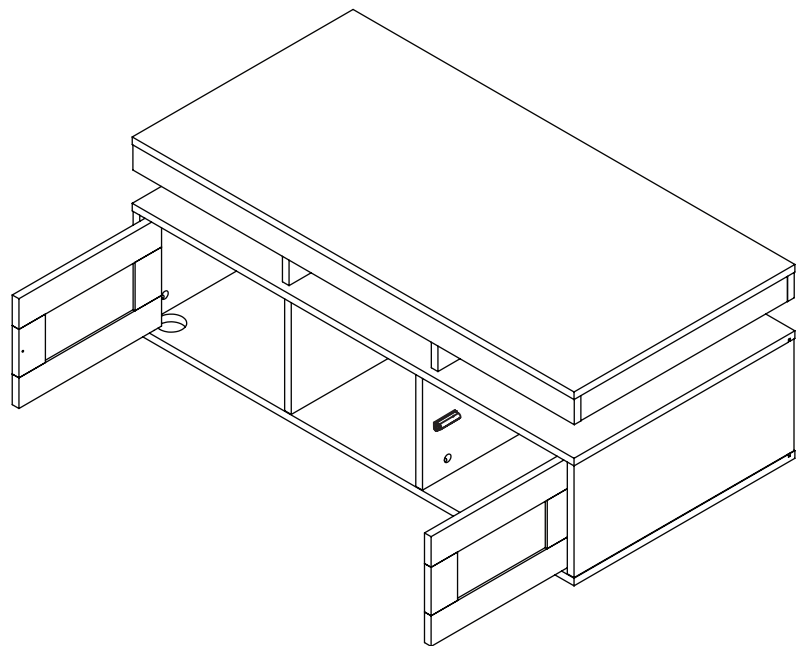
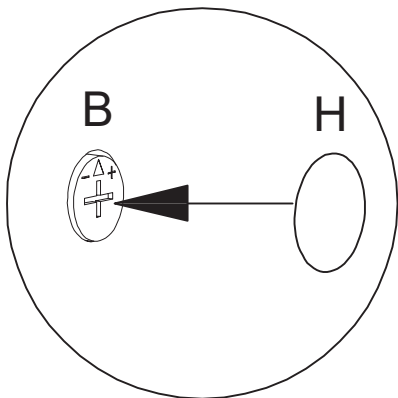

UK: After installing the product, stick the number H on the perforated position

FR: Une fois le produit installé, collez le numéro H à l'endroit où il y a des trous

DE: Nach der Installation des Produkts kleben Sie die Nummer H auf die perforierte Position

IT: Dopo l'installazione del prodotto, fissare il numero H sulla posizione perforata

ES: Después de instalar el producto, pegue el número H en la posición perforada

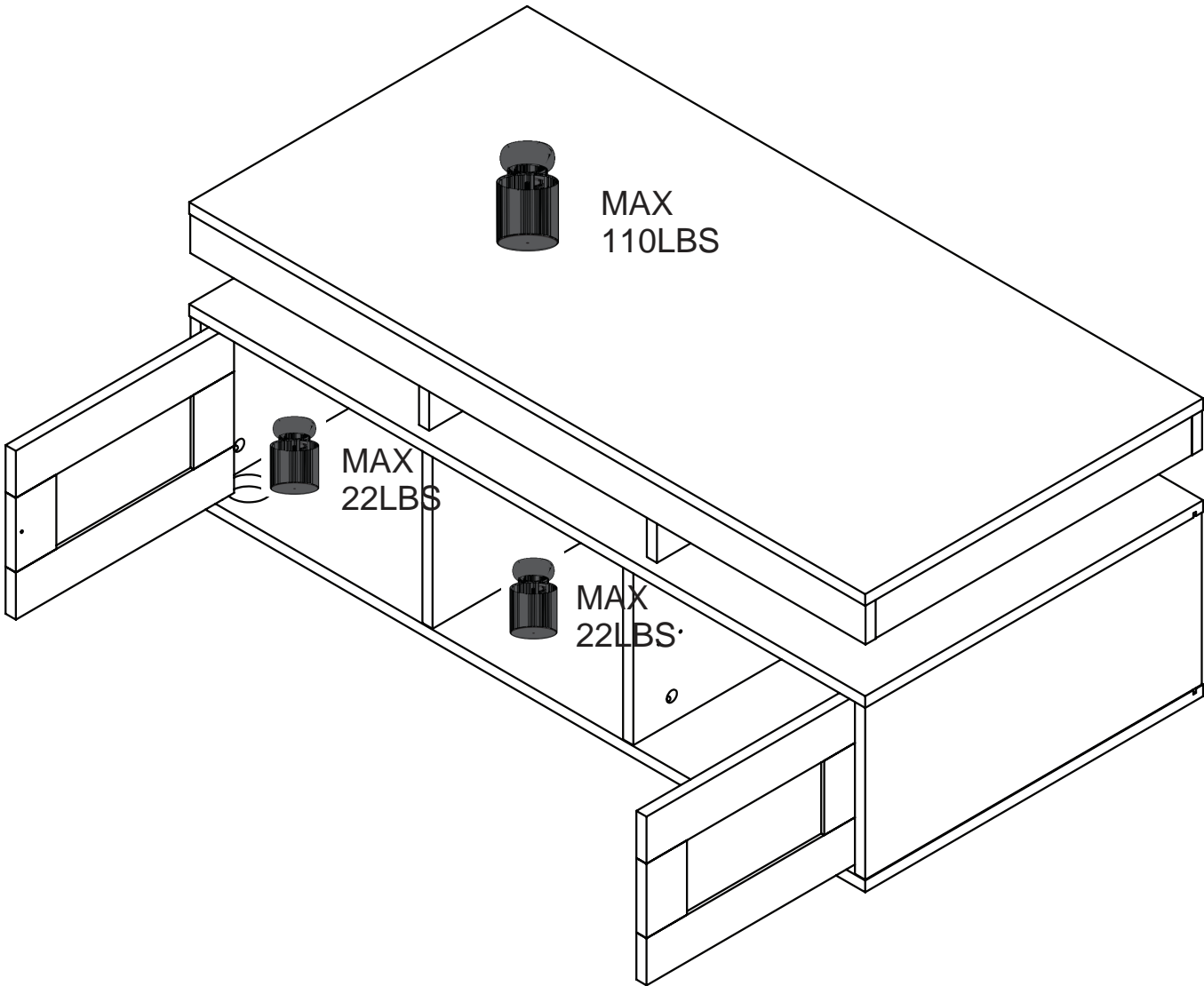

MAX
110LBS

MAX
22LBS

MAX
22LBS

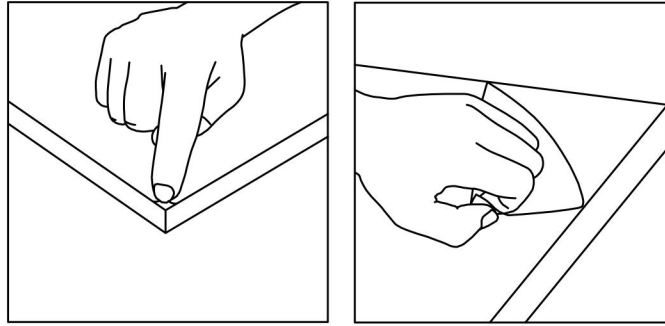

DE:

BITTE BEACHTEN: Die Teile mit den Nummern 1.2.3.7.8.16 sind mit einer festen Kunststoff-Schutzfolie bedeckt. Falls nach dem Auspacken Kratzer auf dem Produkt zu sehen sind, keine Sorge - dies sind keine Beschädigungen. Bitte die Schutzfolie langsam vom Rand her abziehen. Nach dem Entfernen ist das Produkt glatt und sauber.

EN:

PLEASE NOTE: Part numbers 1.2.3.7.8.16 are covered with a tight plastic protective film. If there are scratches on the product after unpacking, please don't worry, it's not product damage. Please slowly peel off the protective plastic film from the edge. After removal, the product becomes smooth and clean.

IT:

SI PREGA DI NOTARE: I pezzi con numeri 1.2.3.7.8.16 sono ricoperti da una pellicola protettiva di plastica aderente. Se dopo lo spaccettamento si notano graffi sul prodotto, non preoccupatevi, non è un danno al prodotto. Rimuovete lentamente la pellicola protettiva dal bordo. Una volta rimossa, il prodotto risulterà liscio e pulito.

FR:

VEUILLEZ NOTER: Les pièces portant les numéros 1.2.3.7.8.16 sont recouvertes d'un film protecteur en plastique serré. Si des rayures apparaissent sur le produit après le déballage, ne vous inquiétez pas, ce ne sont pas des dommages. Veuillez décoller lentement le film protecteur en plastique à partir du bord. Après retrait, le produit devient lisse et propre.

ES:

TENGA EN CUENTA: Las piezas con números 1.2.3.7.8.16 están cubiertas con una película protectora de plástico ajustada. Si hay arañazos en el producto después de desempaquetar, no se preocupe, no es daño del producto. Retire lentamente la película protectora de plástico desde el borde. Después de quitarla, el producto quedará liso y limpio.

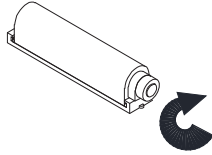

DE: Wenn die Schublade/Tür mit Auslöser (Teil: J) nach außen vorsteht, drehen Sie den Auslöser im Uhrzeigersinn, bis er sanft die Innenseite der Front berührt

FR: Si le tiroir/porte avec loquet (Pièce : J) dépasse vers l'extérieur, tournez le loquet dans le sens horaire jusqu'à ce qu'il touche légèrement l'intérieur du panneau.

EN: If the drawer/door with push-latch (Part: J.) protrudes outward rotate the latch clockwise until it gently touches the inner side of the panel

IT: Se la cassetta/anta con dispositivo (Parte: J) sporge verso l'esterno, ruotare il dispositivo in senso orario finché non tocca leggermente la parte interna del pannello

ES: Si el cajón/puerta con mecanismo de retroceso (Pieza: J), sobresale hacia afuera, gire el mecanismo en sentido horario hasta que toque suavemente el interior del panel.

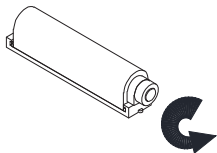

DE: Wenn die Schublade/Tür mit Auslöser (Teil: J) nach innen versenkt ist, drehen Sie den Auslöser gegen den Uhrzeigersinn, bis er sanft die Innenseite der Front berührt.

FR: Si le tiroir/porte avec loquet (Pièce : J) est enfoncé vers l'intérieur, tournez le loquet dans le sens antihoraire jusqu'à ce qu'il touche légèrement l'intérieur du panneau.

EN: If the drawer/door with push-latch (Part: J) is recessed inward, rotate the latch counterclockwise until it gently touches the inner side of the panel

IT: Se la cassetta/anta con dispositivo (Parte: J) è rientrato verso l'interno, ruotare il dispositivo in senso antiorario finché non tocca leggermente la parte interna del pannello

ES: Si el cajón/puerta con mecanismo de retroceso (Pieza: J) está hundido hacia adentro, gire el mecanismo en sentido antihorario hasta que toque suavemente el interior del panel.

APP-PROGRAMMANWENDUNG

Klicken, um
Lampenliste
anzuzeigen
Farbrad
wechseln

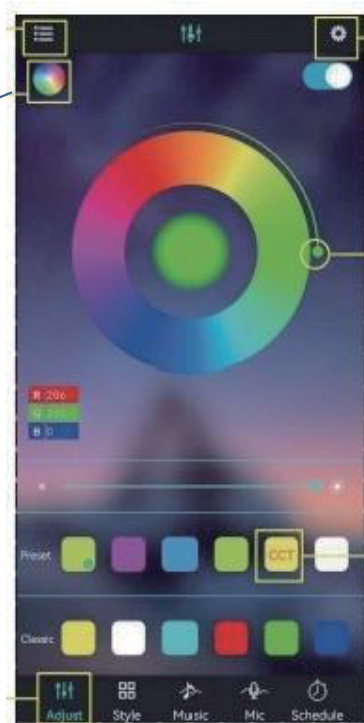

Klicken für
Einstellungsansicht

Farbe anpassen

Farbanpassung
per Quadrat-
Symbol

Schnittstelle
durch Klicken
wechseln



HINWEIS:

Detaillierte Anleitung im
Menü "Guide"

PRODUKTPARAMETER

- Bluetooth: BLEVA 2
- Eingangsspannung: 4.5~26V
- Betriebstemperatur: -25~75 °C
- Abmessungen: 43×22×11 mm
- Gewicht: 30g
- Max. Leistung: 144W (24V)

VERBINDUNGSSCHRITTE

- ① LED-Farbstreifen & Controller verbinden, Controller einschalten
- ② QR-Code scannen zum App-Download:



- ③ App starten, Controller suchen & verbinden
- ④ Bluetooth-Drahtlossteuerung genießen

PRODUKTMERKMALE

- Direkte Handy-Steuerung (20m Reichweite)
- Automatische Verbindung in 5 Sekunden
- Musikrhythmus-Synchronisation
- Gruppensteuerung
- Helligkeits-/Geschwindigkeitsregelung
- Unterstützt bis 10m RGB(W)-Streifen
- Automatische Sprachumschaltung (DE/EN)

ANIMATIONSEFFEKTE

- Farbverläufe
- Einfarbige/ Zweifarbige Gradienten
- Monochrome/Bunte Blinkeffekte
- Farbspringen
- Musikresponsive Effekte

APP PROGRAM USAGE

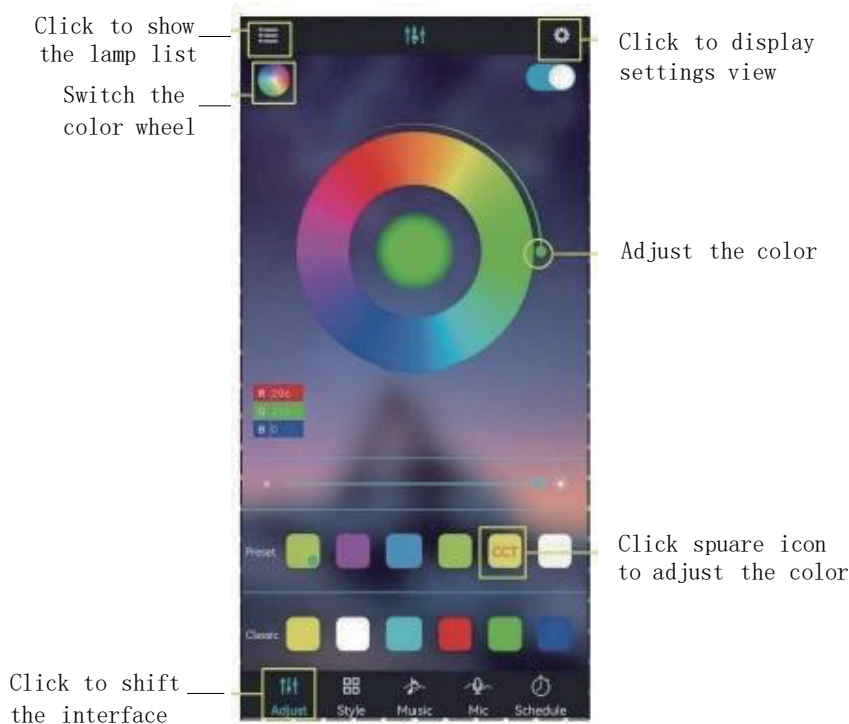

- Scan two-dimensional code download APP
- ①Connect LED color strip and controller, power on controller
 - ②Scan two-dimensional code download APP:



- ③Start APP, search and connect controller
- ④Enjoy the Bluetooth wireless control experience



Notes:
detailed operating instructions,
enter the menu "Guide":

Product Paramters:

- Bluetooth:BLEV4.2
- Input Voltage:4.5~26V
- Working Temp:-25~75°C
- Size:43*22*11mm
- Weight:30g
- Max Power:144W (24V)

LED mobile phone Bluetooth controllerProduct Features

- LED Bluetooth controller is directly via mobilephone control remote distance can reach 20m without the need to setupeasy to connect open the software within 5 seconds you can automatically connect the controller
- Flow the rhythm of the music changes
- Group control
- Brightness, speed addition and subtraction
- Maximum can be 10 meters RGB(W) strip
- The software shows that the text is based onthe language of the mobile phone set up automatic transformation of Chinese and English

ANIMATION EFFECTS:

- Colorful gradient
- All kinds of monochrome, double color gradient
- All kinds of monochrome, double color, colorfull flashing
- Colorful jump
- Follow the thymhm of the music chagnes

APP-PROGRAMMANWENDUNG

Afficher la
liste des lampes
Farbrad
Changer la
Roue chromatique



Afficher les
paramètres

Ajuster la couleur

Cliquez sur l'icône
carrée pour ajuster
la couleur.

Changer d'
interface
par clic

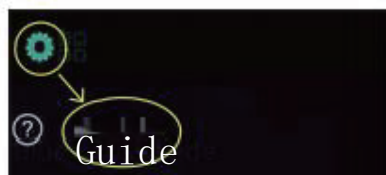

REMARQUE :

Guide détaillé dans le menu
"Guide"

CARACTÉRISTIQUES

- Bluetooth : BLEVA 2
- Tension d'entrée : 4.5~26V
- Température : -25~75° C
- Dimensions : 43×22×11 mm
- Poids : 30g
- Puissance max : 144W (24V)

ÉTAPES DE CONNEXION

- ① Connecter bande LED & contrôleur, allumer
- ② Scanner QR code pour télécharger l'app :



- ③ Lancer l'app, rechercher & connecter
- ④ Profiter du contrôle Bluetooth sans fil

FONCTIONNALITÉS

- Contrôle direct par smartphone (20m)
- Connexion automatique en 5 secondes
- Synchronisation musicale
- Contrôle de groupe
- Réglage luminosité/vitesse
- Prise en charge bandes ≤10m RGB(W)
- Basculage automatique FR/EN

EFFETS D'ANIMATION

- Dégradés de couleurs
- Dégradés uni/bicolores
- Clignotements mono/colorés
- Saut de couleurs
- Effets réactifs à la musique

UTILIZZO APP



PASSI CONNESSIONE

- ① Collega striscia LED & controller, accendi
- ② Scansiona QR code per scaricare APP:



- ③ Avvia APP, cerca & connetti controller
- ④ Goditi controllo wireless Bluetooth



NOTA:

Guida completa nel menu "Guide"

SPECIFICHE:

- Bluetooth: BLEVA 2
- Tensione ingresso: 4.5~26V
- Temperatura: -25~75° C
- Dimensioni: 43×22×11 mm
- Peso: 30g
- Potenza max: 144W (24V)

CARATTERISTICHE

- Controllo diretto smartphone (20m)
- Connessione automatica in 5 secondi
- Sincronizzazione ritmo musicale
- Controllo di gruppo
- Regolazione luminosità/velocità
- Supporto strisce ≤10m RGB(W)
- Auto switch IT/EN

EFFETTI ANIMAZIONE:

- Sfumature colore
- Gradienti mono/bicolori
- Luci lampeggianti mono/colorate
- Salto colori
- Effetti reattivi alla musica

USO DE LA APLICACIÓN

Mostrar lista de —
Lámparas
Cambiar rueda de color

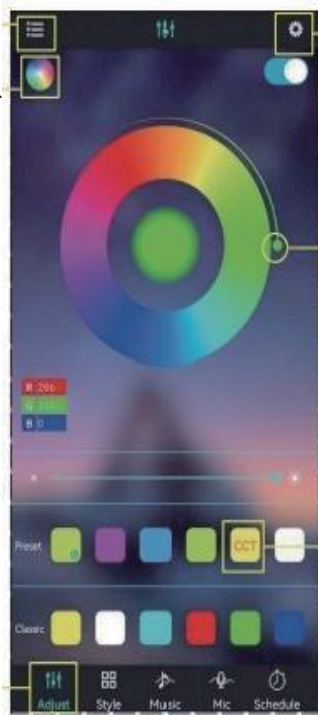

Ver ajustes

Ajustar el color

Clicar para ajustar color
con icono cuadrado

Cambiar interfaz
haciendo clic —



NOTA:

Guía completa en menú "Guide"

ESPECIFICACIONES:

- Bluetooth: BLEVA 2
- Voltaje entrada: 4.5~26V
- Temperatura: -25~75° C
- Tamaño: 43×22×11 mm
- Peso: 30g
- Potencia máx: 144W (24V)

PASOS DE CONEXIÓN

- ① Conectar tira LED y controlador, encender
- ② Escanear QR para descargar APP:



- ③ Iniciar APP, buscar y conectar
- ④ Disfrutar control inalámbrico Bluetooth

CARACTERÍSTICAS

- Control directo móvil (20m alcance)
- Conexión automática en 5 segundos
- Sincronización ritmo musical
- Control grupal
- Ajuste brillo/velocidad
- Soporte tiras ≤10m RGB(W)
- Auto cambio ES/EN

EFFECTOS DE ANIMACIÓN:

- Degradados de color
- Transiciones mono/bicolores
- Destellos monocromáticos/color
- Salto de colores
- Efectos reactivos a música



NOWD Testing Services Co., Ltd.

TEL: +86-755-2783 0065 FAX: +86-755-2783 0095

ADD: 5A, Building 29B, Yintian Industrial Zone, Yantian Community,
Xixiang Street, Bao'an District, Shenzhen, China

Email: nowd@nowd.com.cn

Web: http://www.nowd.com.cn

Supplier's Declaration of Conformity

Reference No. : NTS2603095
Report No. : NTS2603095E
Applicant : **Shenzhen Dengdai Yunlian Lighting Co., Ltd**
2nd Floor, Building A, No. 15 Jinkui East Road, Kuiyong Street, Dapeng
New District, Shenzhen , Guangdong, China
Manufacturer : **Shenzhen Dengdai Yunlian Lighting Co., Ltd**
2nd Floor, Building A, No. 15 Jinkui East Road, Kuiyong Street, Dapeng
New District, Shenzhen , Guangdong, China
Product : Furniture socket
Model No. : **ZG-JJM**
Trade Mark : ZG-JJM-A1 , ZG-JJM-A2 , ZG-JJM-A3

*Therefore, NTS hereby acknowledges that the manufacturer may issue a verification of conformity.
That this product has been tested according to the following Standard:*

Test Standards ICES-003 Issue 7 October 2020

*The statement is based on a single evaluation of one sample of above mentioned products. It does not
imply an assessment of the whole production.*

*The practice should ensure that all products in series production are in conformity with the product
sample detailed in this report. The applicants should hold the whole technical report at the notice of the
competent all the right.*

The label should be permanently attached to each unit of the lighting fixture:

CAN ICES-3 (B)/NMB-3B)



Signed for and on behalf of
NOWD Testing Services Co., Ltd.

Somnus

Technical Manager

Date: Mar 16.2026

This authorizes the application of the Certification Mark(s) shown below to the models described in the Product(s) Covered section when made in accordance with the conditions set forth in the Certification Agreement and Listing Report. This authorization also applies to multiple listee model(s) identified on the correlation page of the Listing Report.

This document is the property of Intertek Testing Services and is not transferable. The certification mark(s) may be applied only at the location of the Party Authorized To Apply Mark.

Applicant:	Hanron Lighting Co., Limited	Manufacturer:	Hanron Lighting Co., Limited
Address:	3/F, NO.1, Jintai Road, Second Industrial Park, Shangwu Community, Shiyan, Bao'an District, Shenzhen, 518108, Guangdong	Address:	3/F, NO.1, Jintai Road, Second Industrial Park, Shangwu Community, Shiyan, Bao'an District, Shenzhen, 518108, Guangdong
Country:	China	Country:	China
Contact:	Ivan Huang, Jacky Chen	Contact:	Ivan Huang, Jacky Chen
Phone:	+86 13076992505 +86 13829777687	Phone:	+86 13076992505 +86 13829777687
FAX:	NA	FAX:	NA
Email:	info@hanronlighting.com, jacky@hanronlighting.com	Email:	info@hanronlighting.com, jacky@hanronlighting.com

Party Authorized To Apply Mark: Same as Manufacturer
Report Issuing Office: Intertek Testing Services Shanghai Limited.

Control Number: 5014155 **Authorized by:**  _____
for L. Matthew Snyder, Certification Manager



This document supersedes all previous Authorizations to Mark for the noted Report Number.

This Authorization to Mark is for the exclusive use of Intertek's Client and is provided pursuant to the Certification agreement between Intertek and its Client. Intertek's responsibility and liability are limited to the terms and conditions of the agreement. Intertek assumes no liability to any party, other than to the Client in accordance with the agreement, for any loss, expense or damage occasioned by the use of this Authorization to Mark. Only the Client is authorized to permit copying or distribution of this Authorization to Mark and then only in its entirety. Use of Intertek's Certification mark is restricted to the conditions laid out in the agreement and in this Authorization to Mark. Any further use of the Intertek name for the sale or advertisement of the tested material, product or service must first be approved in writing by Intertek. Initial Factory Assessments and Follow up Services are for the purpose of assuring appropriate usage of the Certification mark in accordance with the agreement, they are not for the purposes of production quality control and do not relieve the Client of their obligations in this respect.

Intertek Testing Services NA Inc.
 545 East Algonquin Road, Arlington Heights, IL 60005
 Telephone 800-345-3851 or 847-439-5667 Fax 312-283-1672

Standard(s):	Low Voltage Lighting Systems [UL 2108:2015 Ed.2+R:30May2017] Luminaires [CSA C22.2#250.0:2018 Ed.4]
Product:	Low voltage lighting strip
Models:	HR-F- followed by 5V, 12V or 24V; followed by -; followed by 3mm, 4mm, 5mm, 6mm, 8mm, 10mm, 12mm, 15mm, 16mm or 20mm; followed by -; followed by 2110, 2216, 2835, 3014, 3528, 5050, 5630 or 5050 RGBW; followed by -; followed by up to 700; followed by -; followed by up to five characters; followed by -; followed by TP20, TP54, TP65, TP66, TP67 or TP68; followed by -; followed by W, C, M, D, W U or U; followed by -; followed by O, 7, 8, 9 or U; followed by -; followed by two numbers.

Technical Acceptance Certificate

Certificat D'acceptabilitat Tècnica

Number / Numéro **ES0001-ISED-10007**

Certified by / Homologué par	LGAI Technological Center, S.A. (APPLUS) - No. ES0001
Company Name / Nom de compagnie	Noble House Home Furnishings Canada Inc. 3-8030 ESQUESING LINE MILTON, Ontario L9T 6W3, Canada
Manufacturer (Name, Address) / Fabricant (Nom, adresse)	Noble House Home Furnishings Canada Inc. 3-8030 ESQUESING LINE MILTON, Ontario L9T 6W3, Canada
Company number / Numéro de compagnie	34367
Approval Date / Date d'approbation	21/08/2025
Certification Number (ISED ID) / Numéro d'homologation (ISDE identifiant)	34367-CWG5050RGB
Hardware Version Identification Number / Numéro d'identification de la version du matériel	CWG-5050RGB-60D-5V
Product Marketing Name / Nom de marque du produit	Light Strip
Host Marketing Name / Nom de marque de l'hôte	N/A
Firmware Version Identification Number / Numéro d'identification de la version logiciel	N/A
Equipment Description / Description de l'équipement	Light Strip with BLE wireless function
Type of Equipment / Genre d'équipement	Other

This document is not valid without its technical annex, whose number coincides with the number of the certificate.
Ce document n'est pas valable sans son annexe technique, dont le numéro coïncide avec le numéro du certificat.

The evaluation of the technical documentation delivered is included in the technical file number: 25/37700798
L'évaluation de la documentation technique fournie est incluse dans le numéro de dossier technique: 25/37700798

I hereby attest that the subject equipment was tested and found in compliance with the noted specification.	<i>J'atteste, par la présente, que le matériel a fait l'objet d'essai et a été jugé conforme à la spécification indiquée</i>
---	--

Bellaterra, 21st August 2025 // 21 août 2025

You can check the validity of this certificate in our website / Vous pouvez vérifier la validité de ce certificat sur notre site



Lluís Boada
Certification Technical Manager
Electrical & Electronics



This certificate will be valid on approval date published in ISED Radio Equipment List (REL).
Ce certificat sera valide à la date d'approbation publiée dans la ISDE Nomenclature du Matériel Radio (NMR)

TECHNICAL ANNEX
ANNEXE TECHNIQUE

ES0001-ISED-10007

Specific test / Essai spécifique								
Test Scope / Portée des tests			Site number ID / Identifiant du numéro de site			Laboratory name / Nom du laboratoire		
Wireless Lab / Laboratoire de matériel sans fil			6819A			DONGGUAN YAXU (AiT) TECHNOLOGY LTD.		
Specification Cahiers des charges	Issue/Amd Numéro de la version/Amd	Date Date	From Frequency De la Fréquence	To Frequency À la Fréquence	Emission Designator Désignatif d'émission	Power Puissance	Field Strength (spurious) Intensité de champ (faux)	Distance Distance
RSS-247	Issue 3	Aug. 2023	2402MHz	2480MHz	1M64F1D	0.0007W	41.19 dBuV/m	3m
General Test / Essai général								
Test Scope (Specification) / Portée du test (spécification)			Site number ID / Identifiant du numéro de site			Laboratory name / Nom du laboratoire		
SAR Test Lab / Laboratoire de DAS (RSS-102, Issue 6– Dec 15, 2023) (RSS-102.SAR.MEAS, Issue 1–Dec 15, 2023)			N/A			N/A		
NS Test Lab / Laboratoire de Stimulation nerveuse ((RSS-102, Issue 6– Dec 15, 2023) (RSS-102.NS.MEAS, Issue 1–Dec 15, 2023)			N/A			N/A		
APD Test Lab / Laboratoire de Densité de puissance absorbée ((RSS-102, Issue 6– Dec 15, 2023) (RSS-102.APD.MEAS, Issue 1–Dec 15, 2023)			N/A			N/A		
IPD Test Lab / Laboratoire de Densité de puissance incidente ((RSS-102, Issue 6– Dec 15, 2023) (RSS-102.IPD.MEAS, Issue 1–Dec 15, 2023)			N/A			N/A		

Reviewer name / title: Duke Huang / Evaluator
 Signed on date: 21st August, 2025

Duke Huang

This certificate is considered valid based on the following conditions:
 The certified products must continue to comply with the latest issue of all applicable ISED standards. This certificate does not constitute a radio licence, where required by the applicable ISED standard(s), a radio license must be obtained from an ISED regional office prior to product operation. The certified products shall not be manufactured, imported, distributed, leased, offered for sale, or sold unless the product certification information is listed on ISED's Radio Equipment List (REL) For ISED and/or CB audit purposes, sample of certified product shall be made available to ISED and/or CB

*Ce certificat est considéré valide sur la base des conditions suivantes :
 Les produits certifiés doivent continuer à être conformes à la dernière version de toutes les normes d'ISED applicables. Ce certificat ne constitue pas une licence radio. Si une licence radio est requise selon la ou les normes d'ISED applicables, la licence radio doit être obtenue auprès du bureau régional d'ISED avant l'exploitation du produit. Les produits certifiés ne doivent pas être fabriqués, importés, distribués, loués, mis en vente ou vendus à moins que les informations relatives à la certification du produit figurent dans la Nomenclature du matériel radio (NMR) d'ISED.
 À des fins d'audit de la part d'ISED et/ou de l'OC, des échantillons de produits certifiés doivent être mis à la disposition d'ISED et/ou de l'OC.*