

ASSEMBLY INSTRUCTION INSTRUCTION DE MONTAGE

SKU:N853P390044

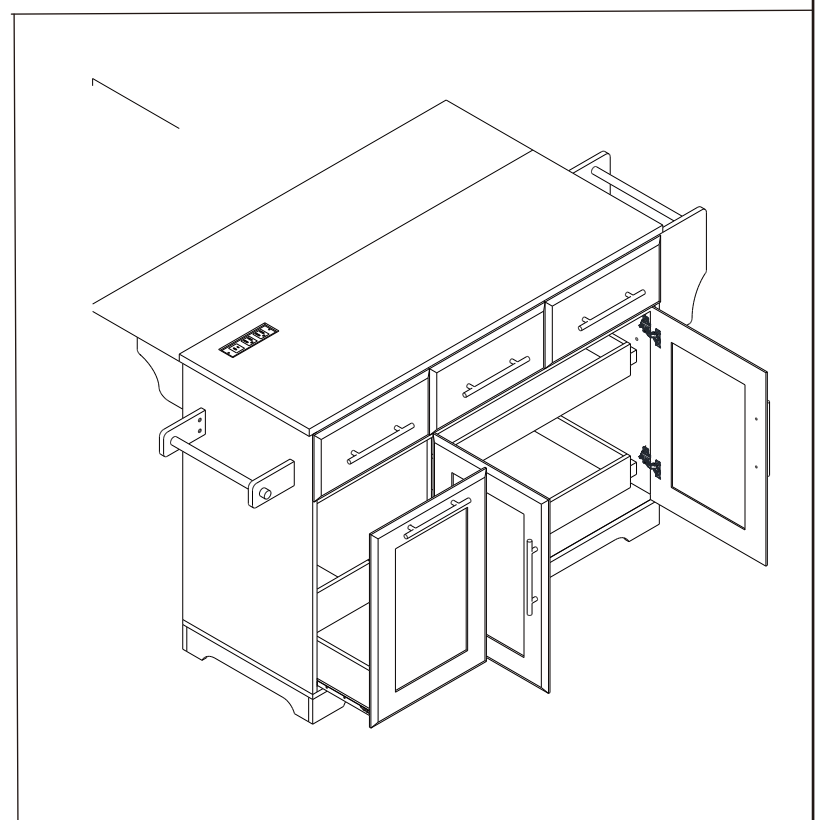
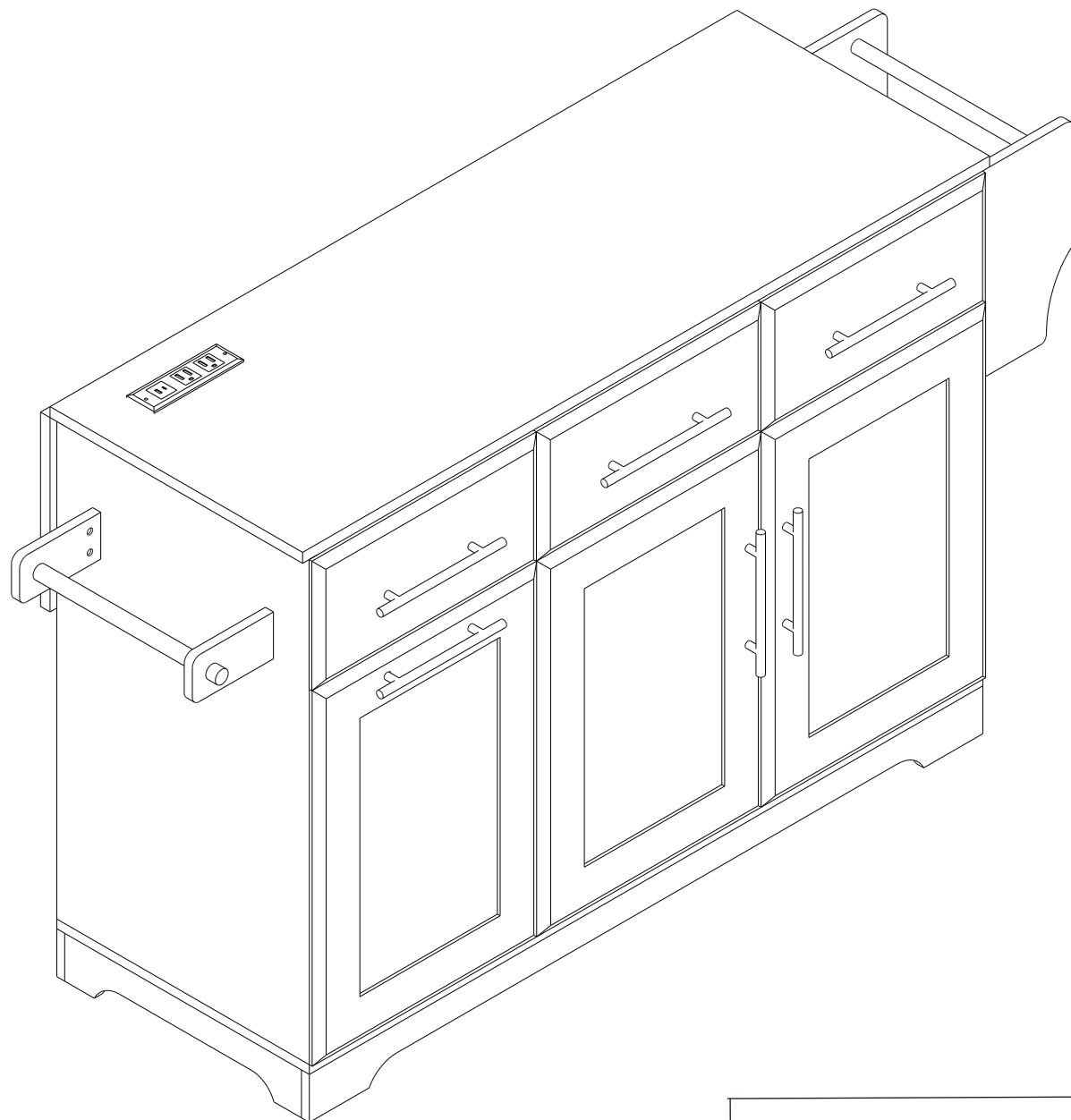

Important - Please read those instructions fully before starting assembly.
Important - veuillez lire ces instructions complètement avant de commencer l'assemblage.

1. Thank you for choosing our products.

2. Return Policy



DO NOT RETURN TO THE STORE! Skip the of process returning your product and contact us directly for a replacement.

If you find that parts of your order are missing or damaged, we will gladly ship any needed replacement parts free of charge. If your product's quality does not meet your expectations or you have found any sort of defect, please contact our customer service department and let us know the details of your order and any issues encountered, we will try our best to provide you with a solution. Feel free to also directly contact our manufacturer concerning needed replacement parts and they will be happy to help provide you with a solution or answer any questions you may have.

Recommendations Before Beginning Assembly

Read instructions, cover to cover

Have 2-4 adults on hand for assembly depending on product size

Do not assemble directly on floating or carpet

Assemble on a clean non-marring surface (example:packing foam)

Save all packaging until finished







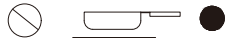

3. Assembly Notice:

If you encounter any problems during assembly and find that you cannot continue, rest assured we will help you solve the situation as soon

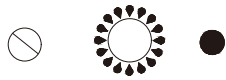
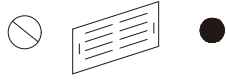
- as possible. Simply keep all of the parts of the products to redina safe place and contact us immediately so we may assist you further.
- Once you have opened your package, remove all inner hardware packages and take the parts out. One by one, Place the parts out neatly infront of you, then refer to the instructions to ensure no parts are missing.If any pieces are found missing, please carefully look in the box first, as the hardware packaging might have torn making the hardware spill in the box. Some key parts of your product maybe stored and hidden inside of other parts. Please open any zippered or hook & loop storage
- Compartments to remove all parts. (example:cushions and legs being stored in the underside of a sofa)
IMPORTANT: When setting up your product, **DO NOT INSTALL THES CREWS ALL THE WAY IN THE BEGINNING.** Place each acrew into their proper hole and use your hand to twist the screw halfway. Twist all the screws in halfway to ensure the holes will match up properly and the product is level on the ground. When everything seems fitted, then tighten thes crews.

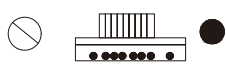
When you have completed assembly, we suggest you have more than one person to assist you with lifting and placing the product.

Care & Maintenance

-  Do not put hot items directly on furniture surface
-  Do not clean furniture with harsh cleansers or polish
-  Do not place furniture under direct sunlight
-  Do not place furniture near heating or cooling vents
-  Do not write on furniture without a padded barrier to protect the surface
-  Do not place furniture outside. For indoor use only
-  Not for commercial use. For residential use only
-  Children should not climb or jump on the furniture
-  Dust and pick-up spills using a clean, non-colored, lint-free cloth
-  Do not place furniture outside. For indoor use only

Caution

This product contains small components. Please ensure that they are kept away from small children.

Do not use power tools to assemble your furniture. Power tools may strip or damage the parts.

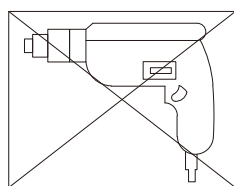

1. Merci d'avoir choisi nos produits.

2. Politique de retour



NE RETOURNEZ PAS AU MAGASIN ! Évitez le processus de retour de votre produit et contactez-nous directement pour un remplacement.

Si vous constatez que certaines pièces de votre commande sont manquantes ou endommagées, nous expédierons volontiers toutes les pièces de remplacement nécessaires gratuitement.

Si la qualité de votre produit ne répond pas à vos attentes ou si vous avez trouvé un quelconque défaut, veuillez contacter notre service client et nous fournir les détails de votre commande ainsi que les problèmes rencontrés, nous ferons de notre mieux pour vous proposer une solution. N'hésitez pas également à contacter directement notre fabricant concernant les pièces de remplacement nécessaires, ils se feront un plaisir de vous aider et de vous fournir une solution ou de répondre à toutes vos questions.

Recommandations avant de commencer l'assemblage

Lisez les instructions, de la première à la dernière page

Prévoir 2 à 4 adultes selon la taille du produit pour l'assemblage

Ne pas assembler directement sur le sol ou sur un tapis

Assemblez sur une surface propre et non abrasive (exemple : mousse d'emballage)

Conservez tous les emballages jusqu'à la fin

● 3. Avis de montage :

Si vous rencontrez des problèmes pendant le montage et que vous ne pouvez pas continuer, sachez que nous vous

- aiderons à résoudre la situation dès que possible. Il vous suffit de garder toutes les pièces des produits dans un endroit sûr et de nous contacter immédiatement afin que nous puissions vous assister davantage.

Une fois que vous avez ouvert votre colis, retirez tous les emballages de matériel interne et sortez les pièces. Une par une, disposez les pièces soigneusement devant vous, puis consultez les instructions pour vous assurer qu'aucune pièce ne manque. Si certaines pièces semblent manquer, veuillez d'abord vérifier attentivement dans la boîte, car

- l'emballage du matériel pourrait s'être déchiré, provoquant la chute des pièces dans la boîte. Certaines pièces clés de votre produit peuvent être stockées et cachées à l'intérieur d'autres pièces. Veuillez ouvrir tout rangement zippé ou à scratch.











Compartiments pour retirer toutes les pièces. (exemple : coussins et pieds rangés sous un canapé)

IMPORTANT : Lors de l'installation de votre produit, **NE VISSER PAS LES VIS COMPLÈTEMENT AU DÉBUT.**

Placez chaque vis dans son trou approprié et utilisez votre main pour tourner la vis à mi-chemin. Vissez toutes les vis à mi-chemin pour vous assurer que les trous s'alignent correctement et que le produit est de niveau au sol. Lorsque tout semble ajusté, serrez alors les vis.

Lorsque vous avez terminé le montage, nous vous suggérons d'avoir plus d'une personne pour vous aider à soulever et à placer le produit.

Entretien et soin

- ⊘  ● Ne placez pas d'objets chauds directement sur la surface des meubles
- ⊘  ● Ne nettoyez pas les meubles avec des produits de nettoyage agressifs ou du polish
- ⊘  ● Ne placez pas les meubles en plein soleil.
- ⊘  ● Ne placez pas les meubles près des bouches de chauffage ou de climatisation.
- ⊘  ● N'écrivez pas sur les meubles sans utiliser une protection rembourrée pour protéger la surface.
- ⊘  ● Ne placez pas les meubles à l'extérieur. Usage intérieur uniquement.
- ⊘  ● Pas pour un usage commercial. Usage résidentiel uniquement.
- ⊘  ● Les enfants ne doivent pas grimper ni sauter sur les meubles.
- ⊘  ● Dépoussiérez et nettoyez les éclaboussures avec un chiffon propre, non coloré et sans peluches.
- ✓  ● Ne placez pas les meubles à l'extérieur. Usage intérieur uniquement.

Attention

Ce produit contient de petites pièces. Veuillez vous assurer qu'elles soient tenues à l'écart des jeunes enfants.

N'utilisez pas d'outils électriques pour assembler vos meubles. Les outils électriques peuvent abîmer ou endommager les pièces.

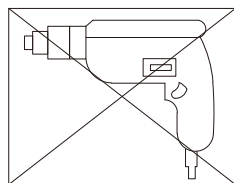

EXPLODED DRAWING:

DESSIN ÉCLATÉ :

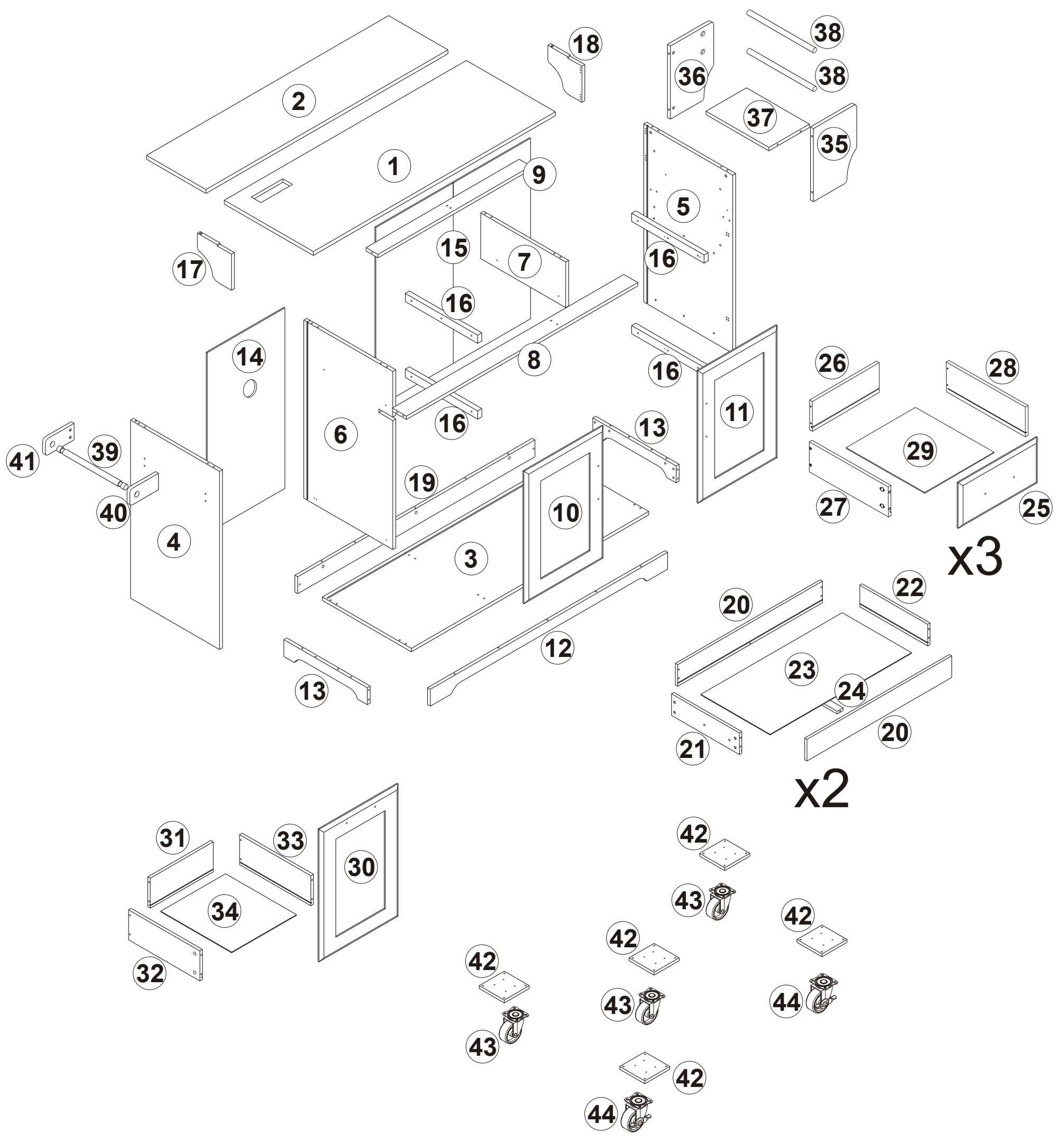

components - fittings

PLEASE CHECK YOU HAVE ALL THE PANELS LISTED BELOW.

Note: The quantities below are the correct amount to complete the assembly.

In some cases more fittings may be supplied than are required.

composants - accessoires

VEUILLEZ VÉRIFIER QUE VOUS AVEZ TOUS LES PANNEAUX LISTÉS CI-DESSOUS.



Remarque : les quantités ci-dessous correspondent au nombre exact nécessaire pour compléter l'assemblage.

Dans certains cas, davantage d'accessoires peuvent être fournis que nécessaire.

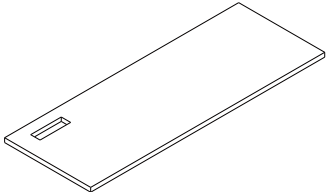
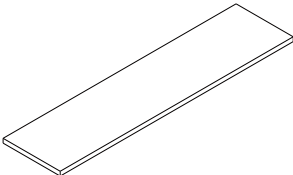
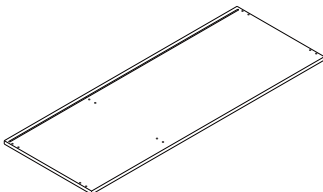
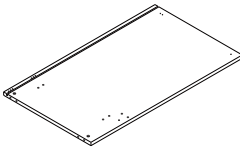
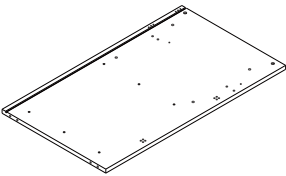
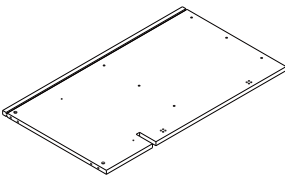
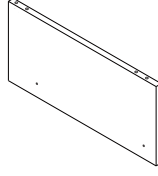
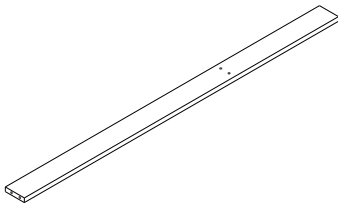
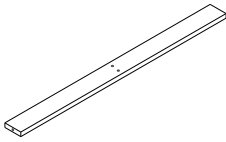
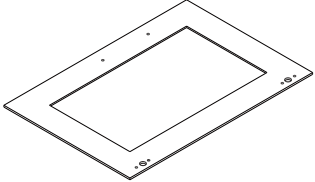
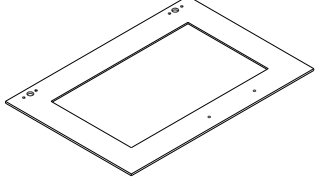
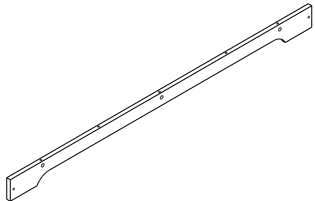
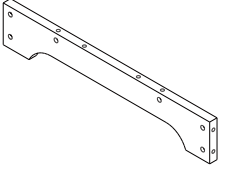
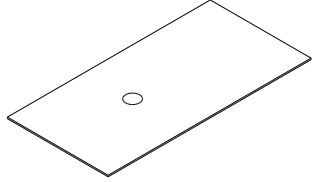
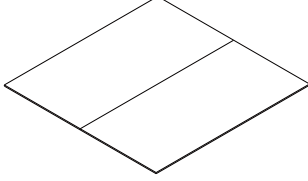
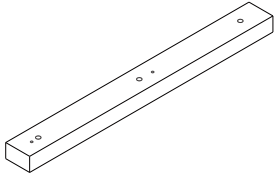
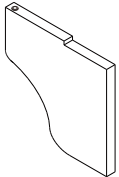
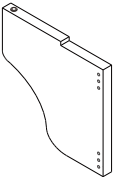
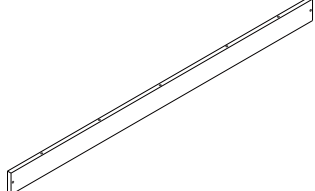
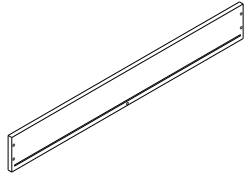
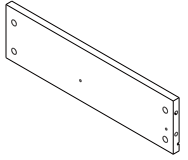
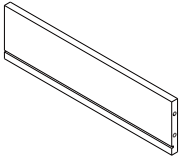
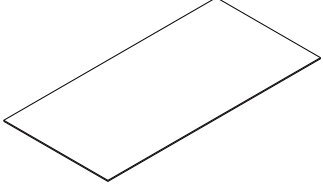
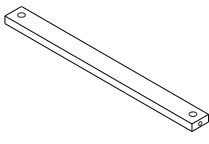
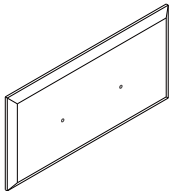
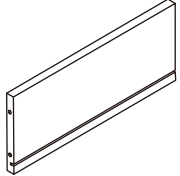
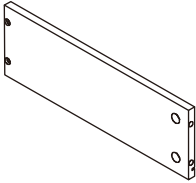
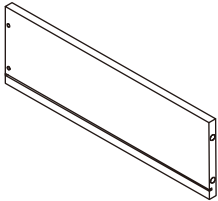



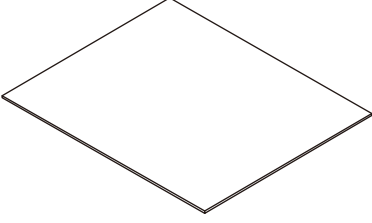
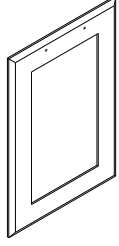
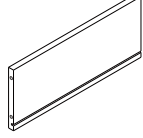
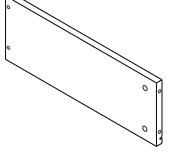
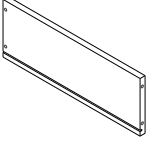
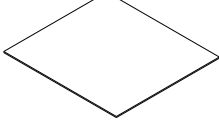

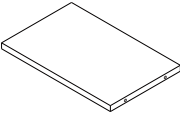
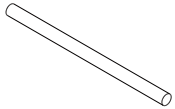
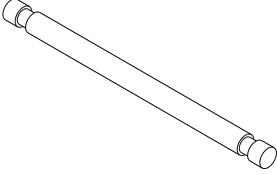
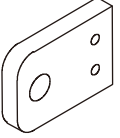
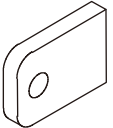
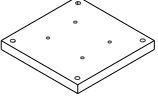
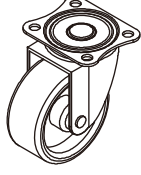
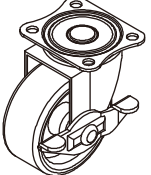

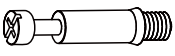

PARTS: PIÈCES :

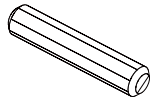
			
① x 1	② x 1	③ x 1	④ x 1
			
⑤ x 1	⑥ x 1	⑦ x 1	⑧ x 1
			
⑨ x 1	⑩ x 1	⑪ x 1	⑫ x 1
			
⑬ x 2	⑭ x 1	⑮ x 1	⑯ x 4
			
⑰ x 1	⑱ x 1	⑲ x 1	⑳ x 4
			
㉑ x 2	㉒ x 2	㉓ x 2	㉔ x 2
			
㉕ x 3	㉖ x 3	㉗ x 3	㉘ x 3

PARTS:

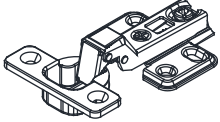
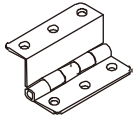
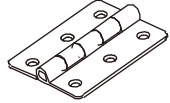
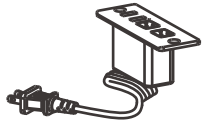
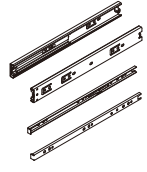
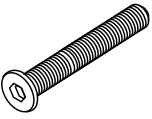
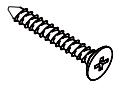
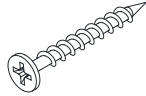
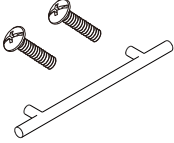
			
②9 x 3	③0 x 1	③1 x 1	③2 x 1
			
③3 x 1	③4 x 1	③5 x 1	③6 x 1
			
③7 x 1	③8 x 2	③9 x 1	④0 x 1
			
④1 x 1	④2 x 5	④3 x 3	④4 x 2

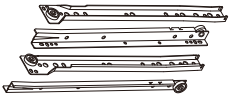
HARDWARE: MATÉRIEL :

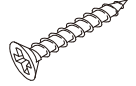
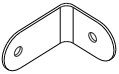
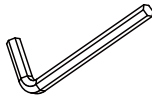
		 Ø6x30mm	 Ø3x12mm	 Ø4x12mm	 Ø4x12mm
A x 66	B x 66	C x 28	D x 60	E x 26	F x 62
					 L=2(L-1)+2(L-2)
G x 8	H x 4	I x 4	J x 3	K x 1	L x 2
 Ø6x40mm	 Ø4x25mm	 Ø4x40mm		 350mm	 400mm
M x 8	N x 32	O x 8	P x 6	Q x 3	R x 1
	 Ø3x14mm	 Ø4x35mm			
S x 8	T x 8	U x 16	V x 1	W x 1	

**Slides Must Be Separated Before Assembly.
After Separated, Set Aside Until Needed for Assembly.**

Las diapositivas deben separarse antes del montaje.
Después de la separación, déjelo a un lado hasta que sea necesario.

Les glissières doivent être séparées avant l'assemblage.
Après la séparation, mettez de côté jusqu'au moment de l'assemblage.

**Pay attention when connecting !
The sliding module must be at the front end.**

**Attention lors du raccordement ! Le module
de glissement doit être en position avant.**

**STEP 1 : Extend Slide
Extender la diapositiva**

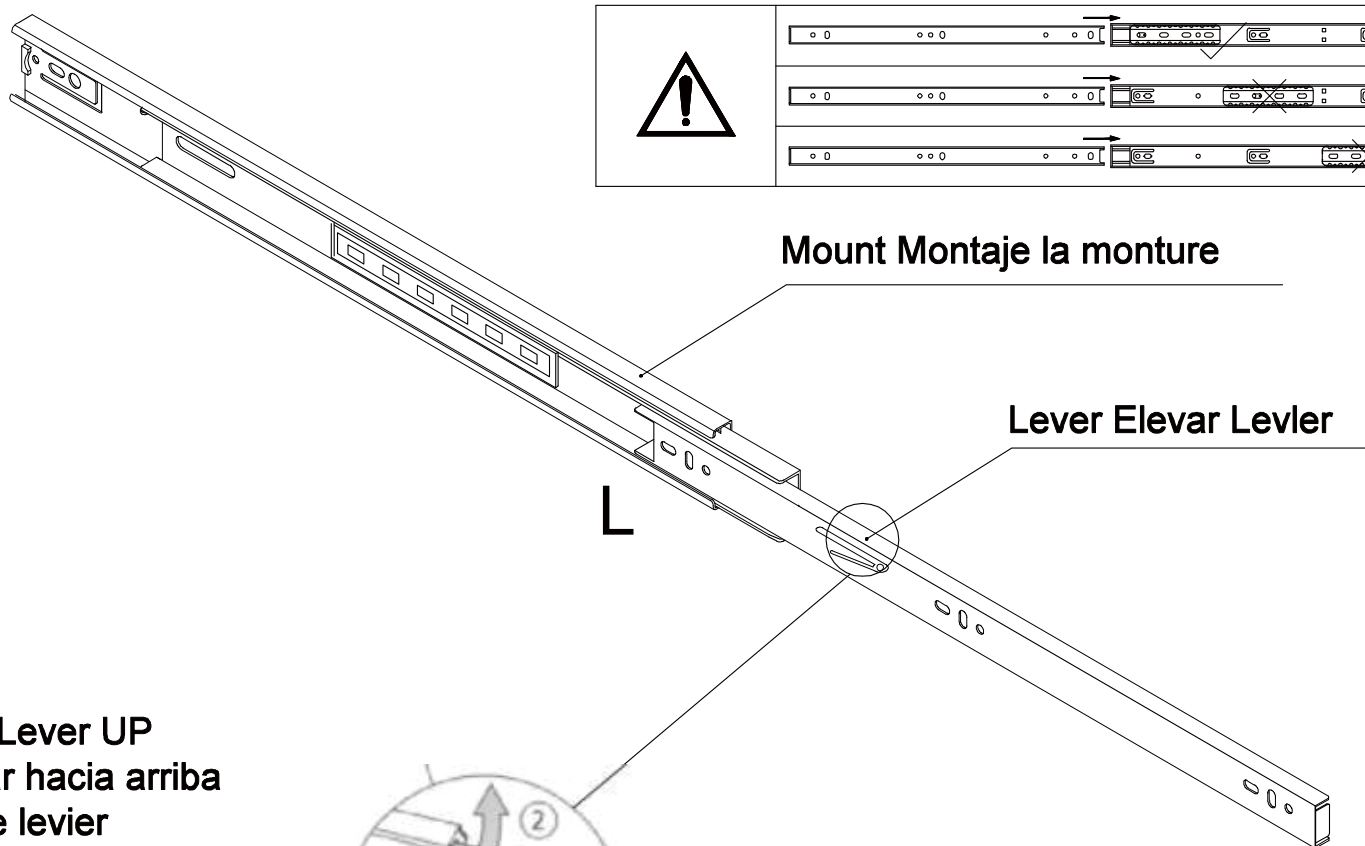
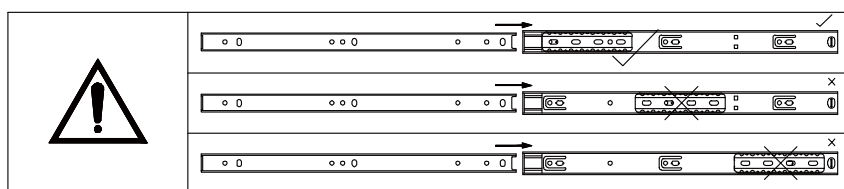

**STEP 2: Push Lever UP
Empujar hacia arriba
Lever le levier**



**Push lever for the left of drawer ,
press the lever for the right of drawer.
Relever le levier du côté gauche du tiroir,
enfoncer le levier du côté droit du tiroir.**

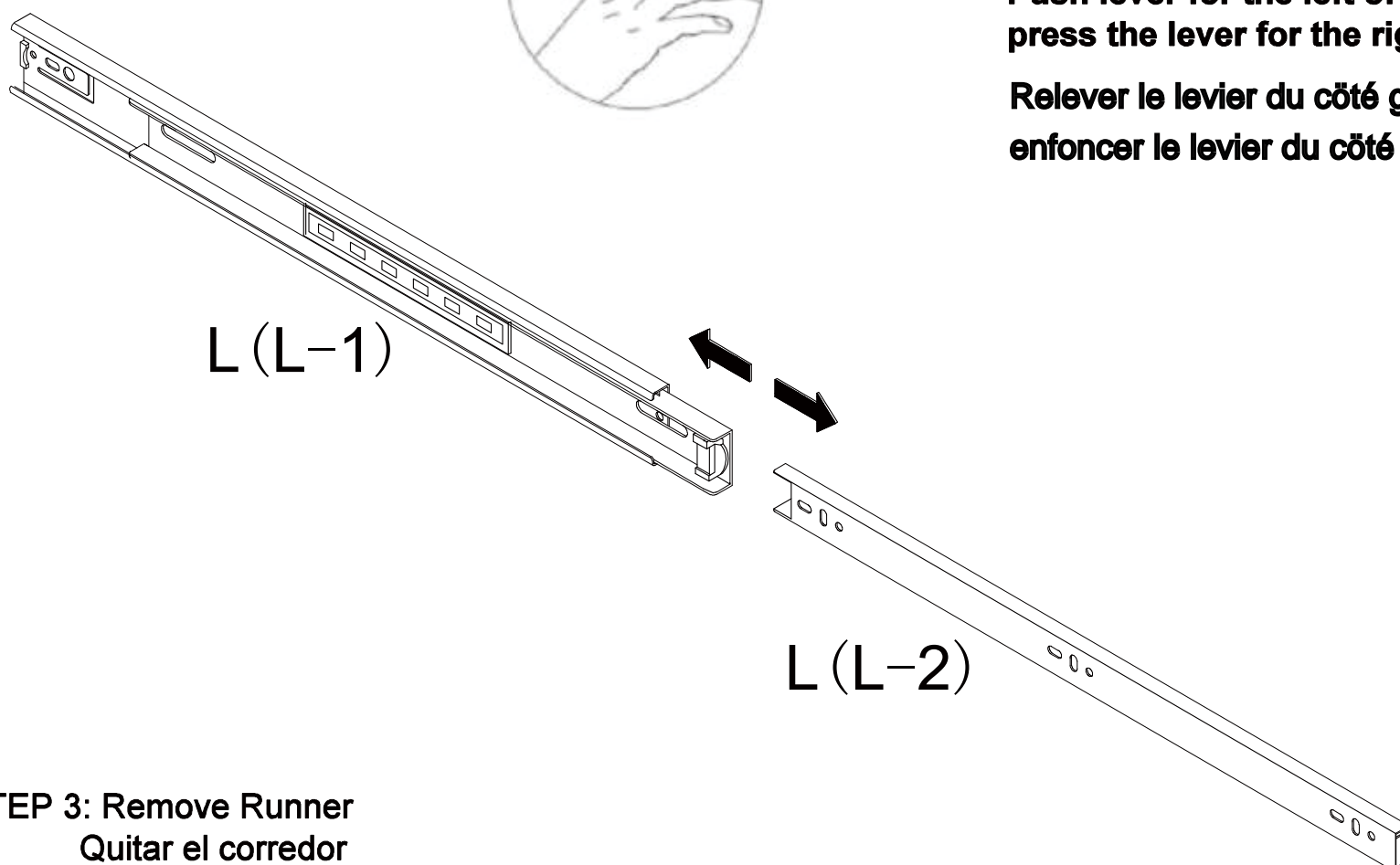

**STEP 3: Remove Runner
Quitar el corredor
Enever le coureur**

step 1

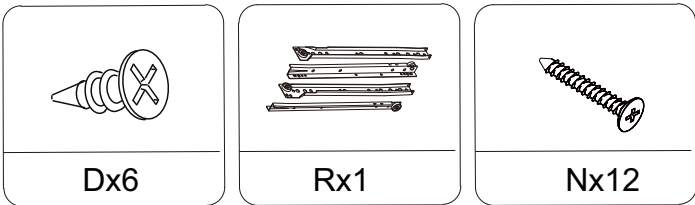
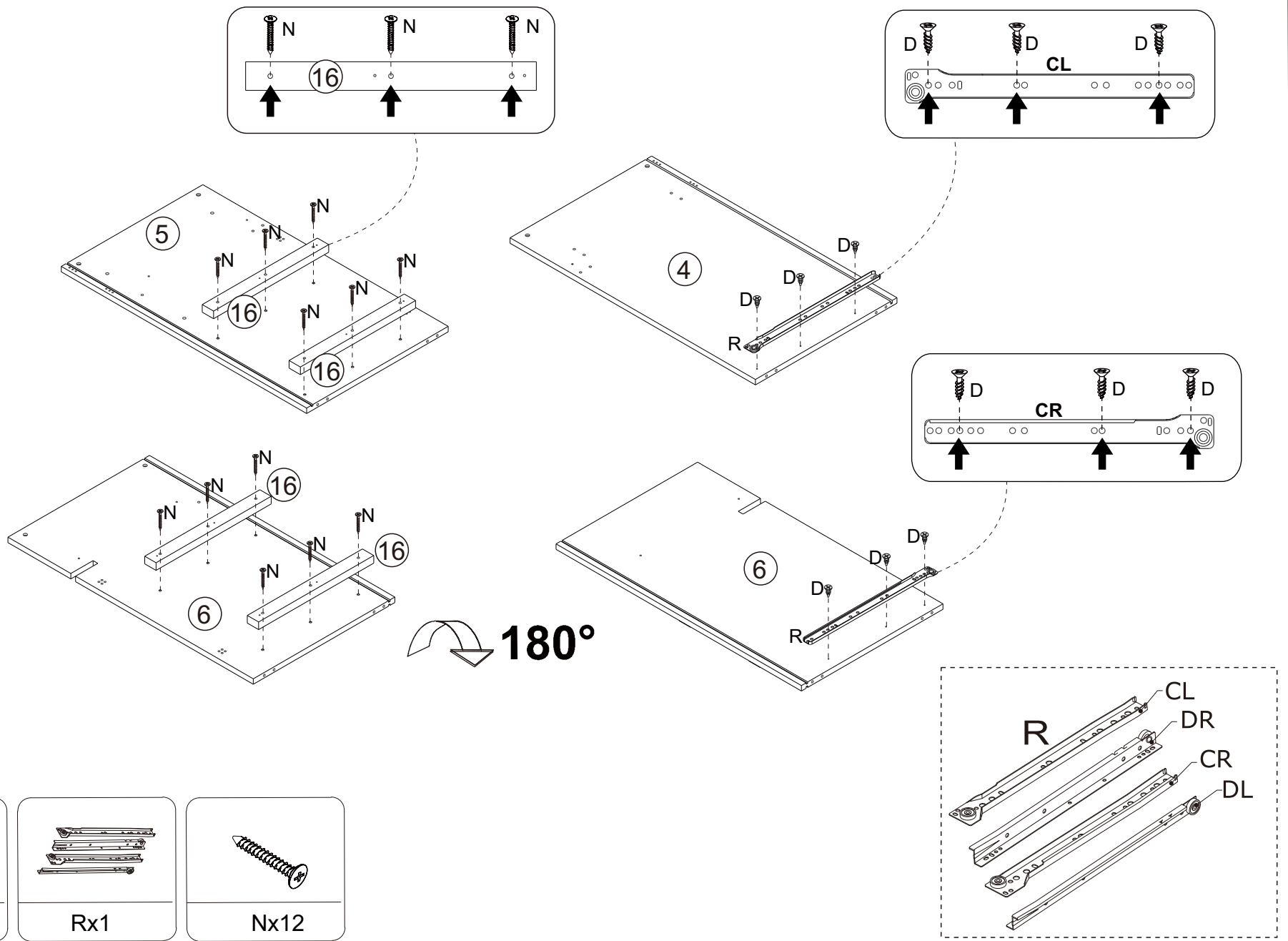

step 2

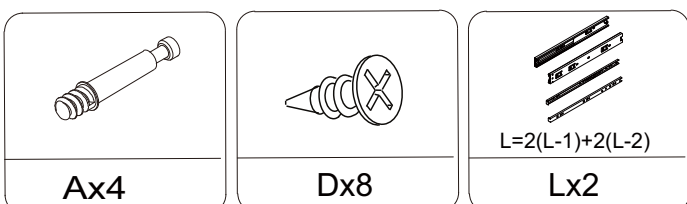
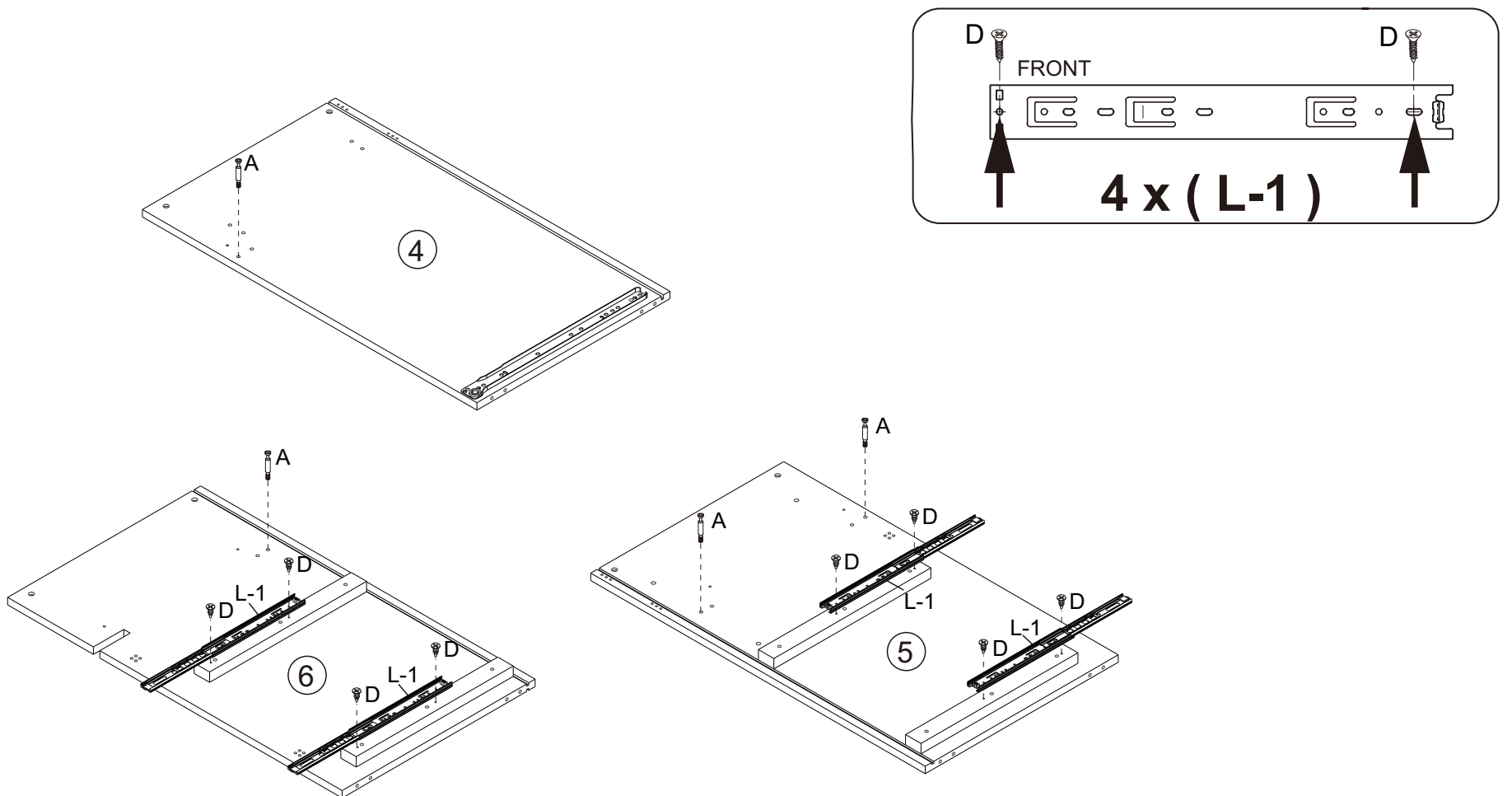

step 3

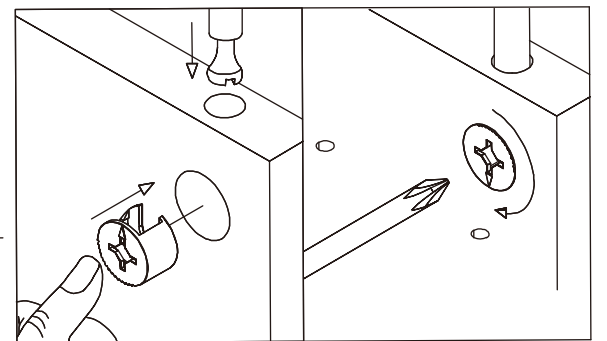
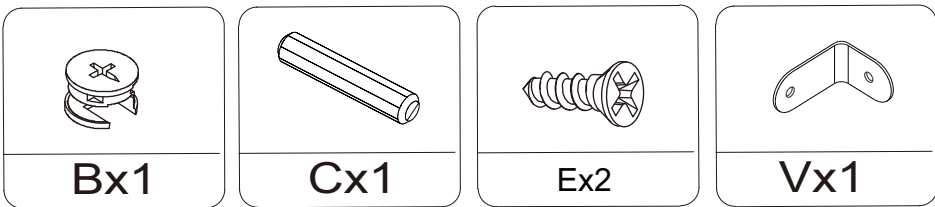
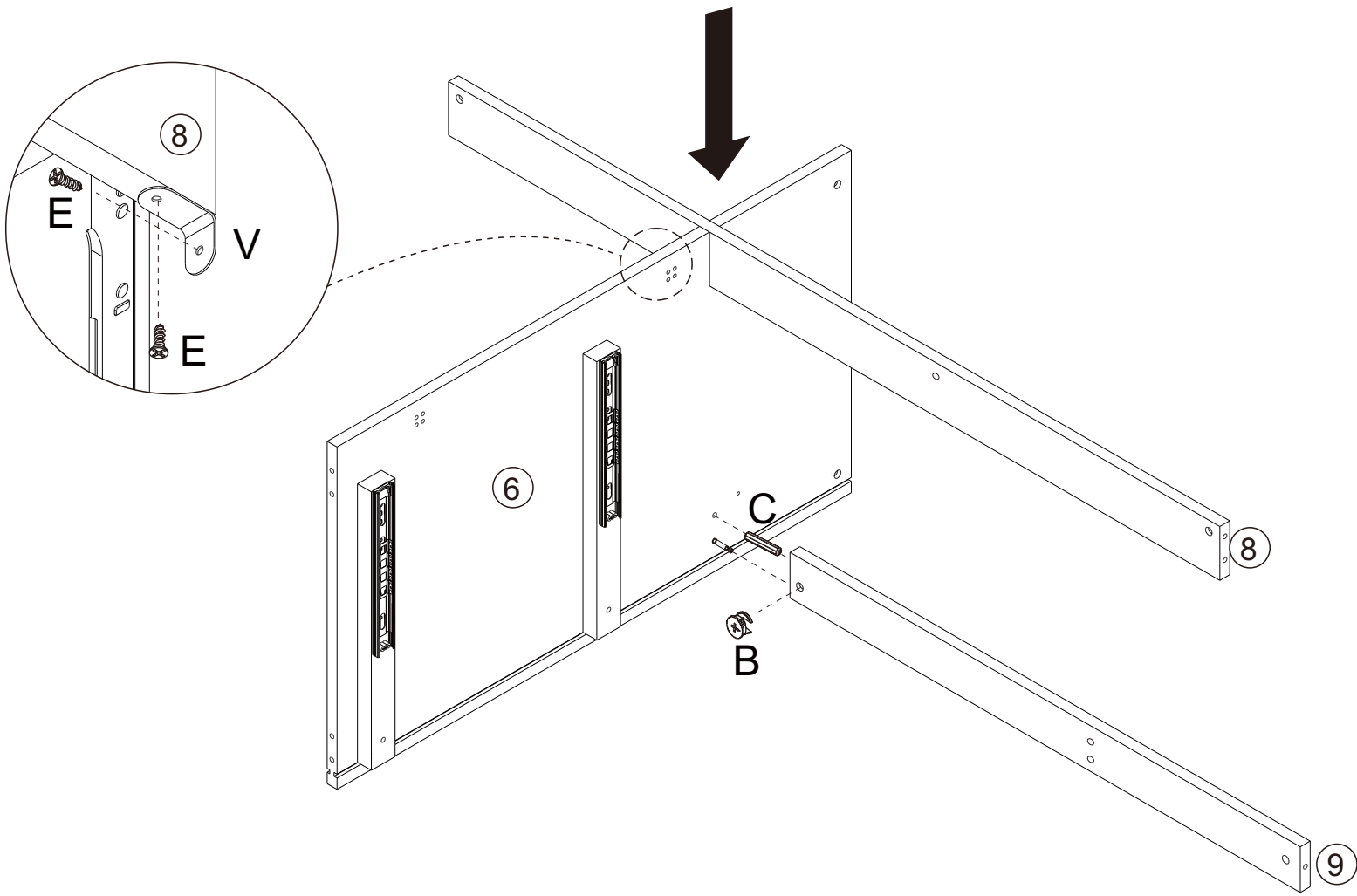

step 4

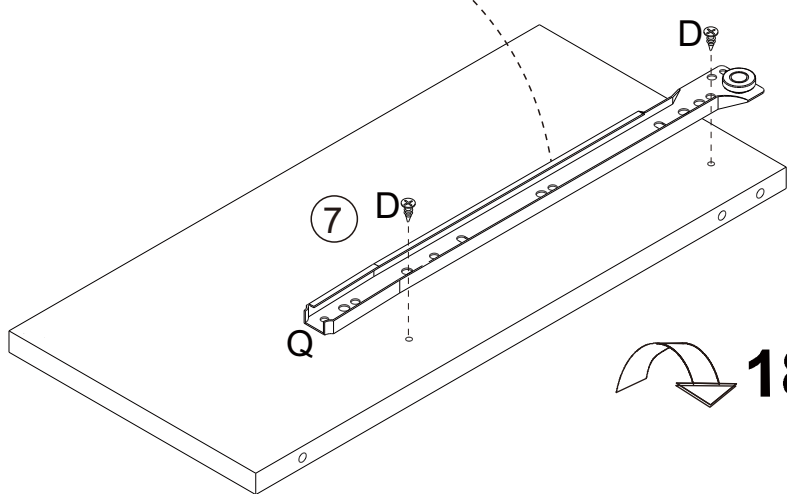
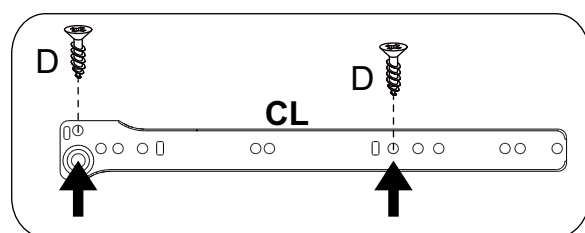
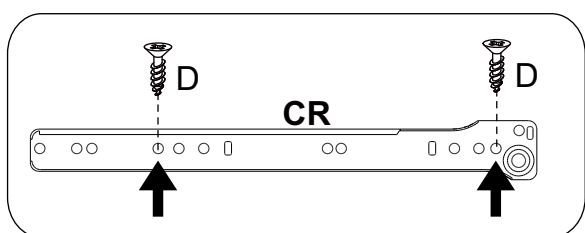

180°

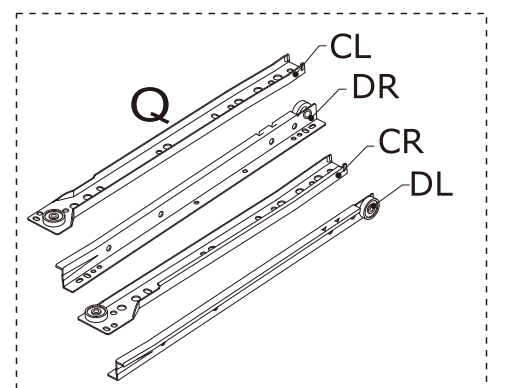
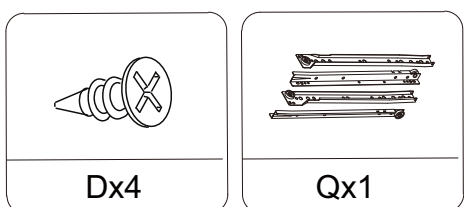
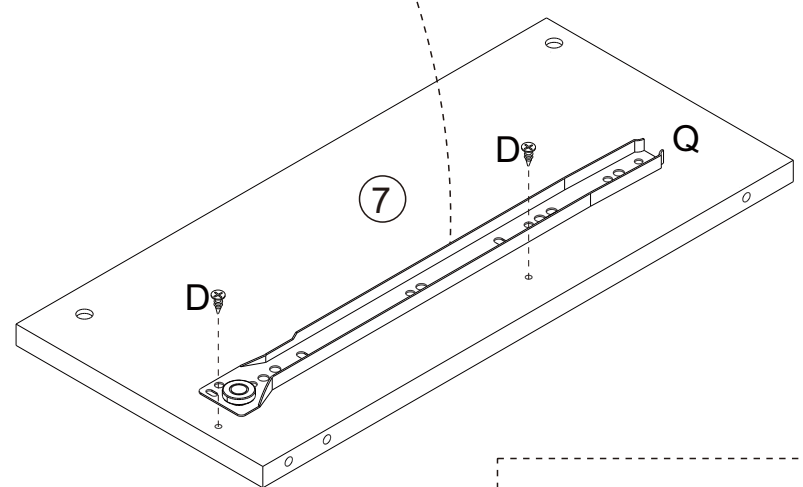

step 5

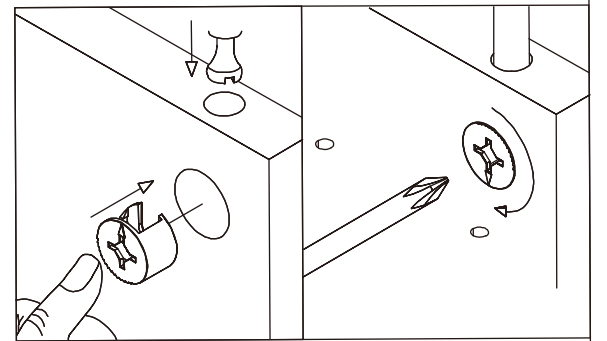
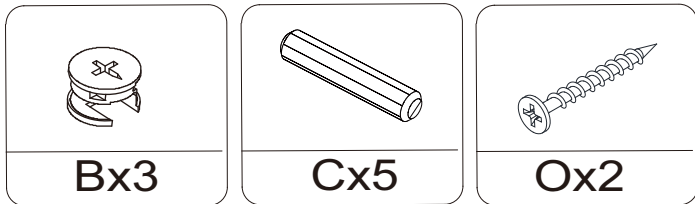
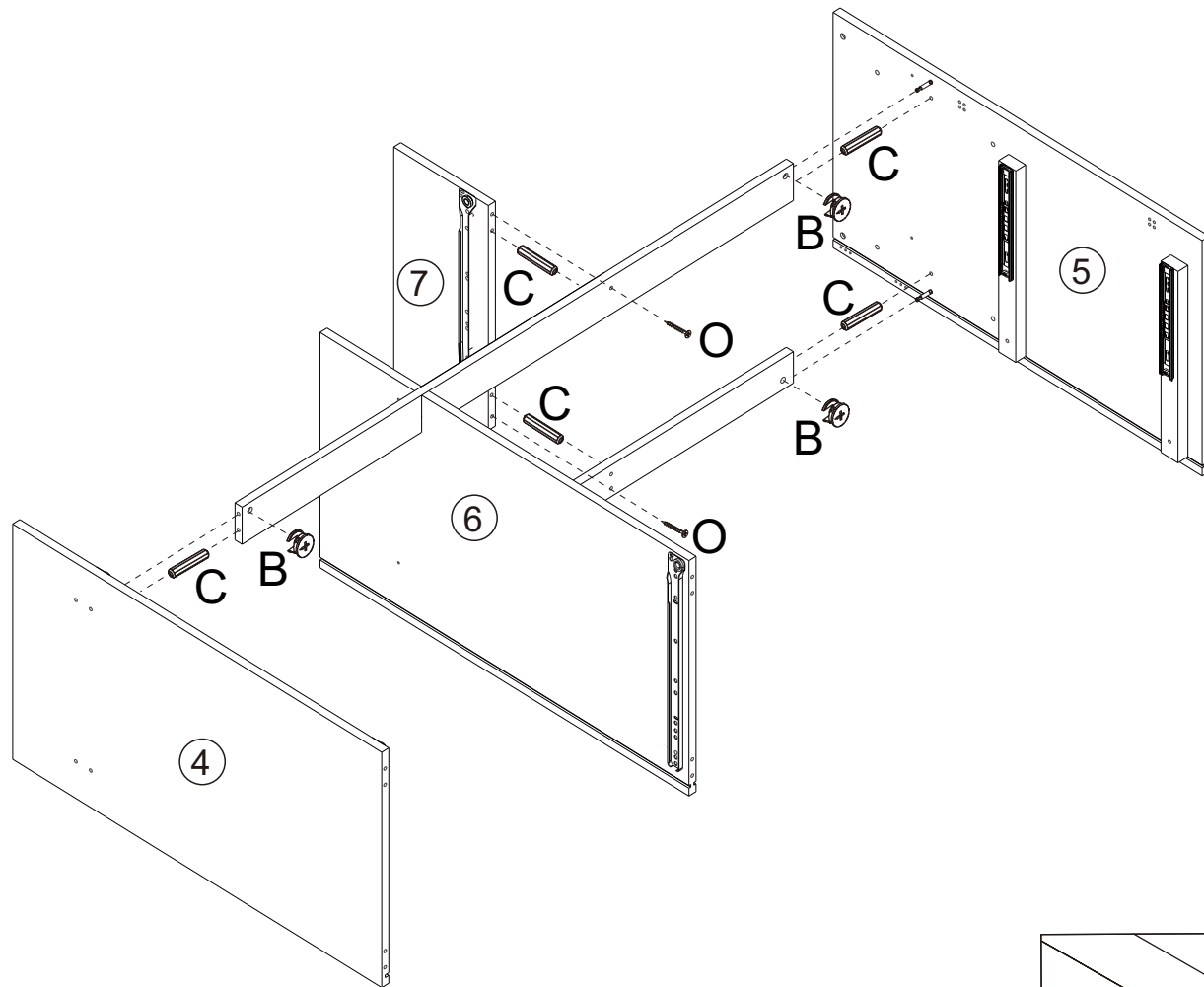

step 6

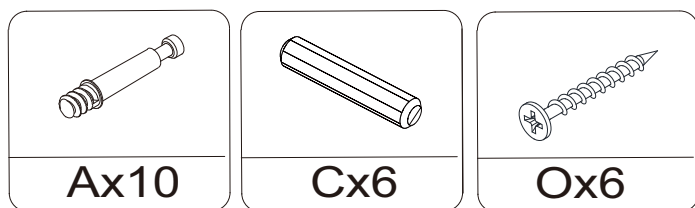
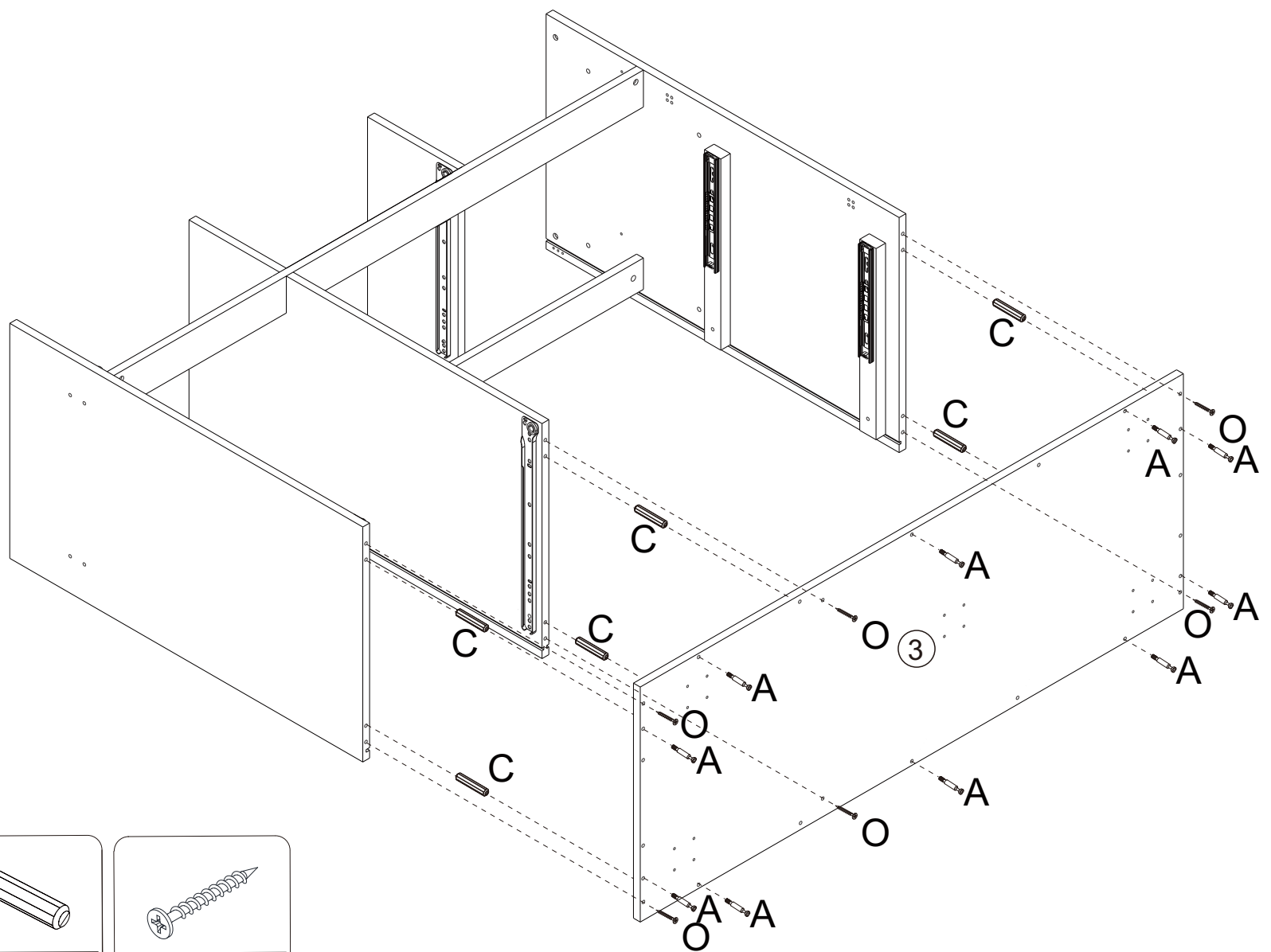

step 7

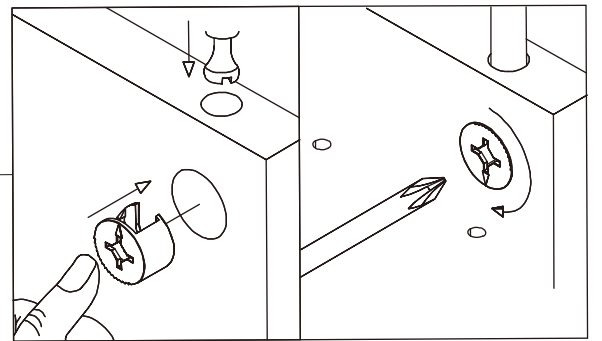
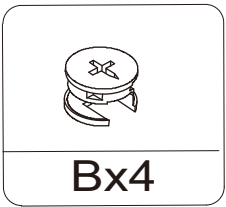
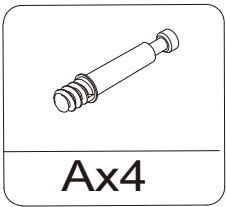
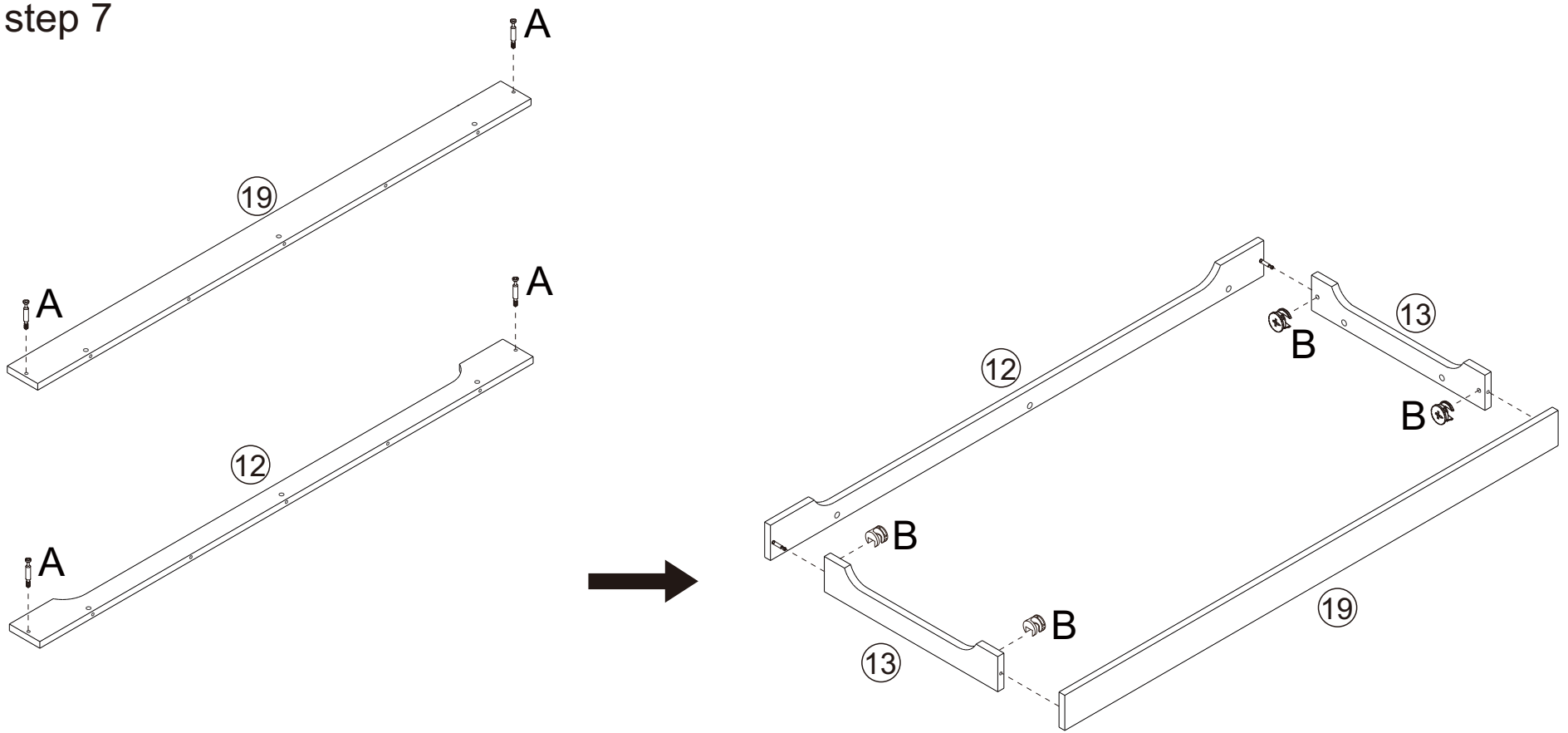

step 8

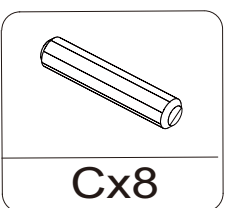
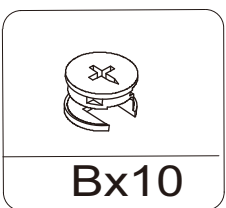
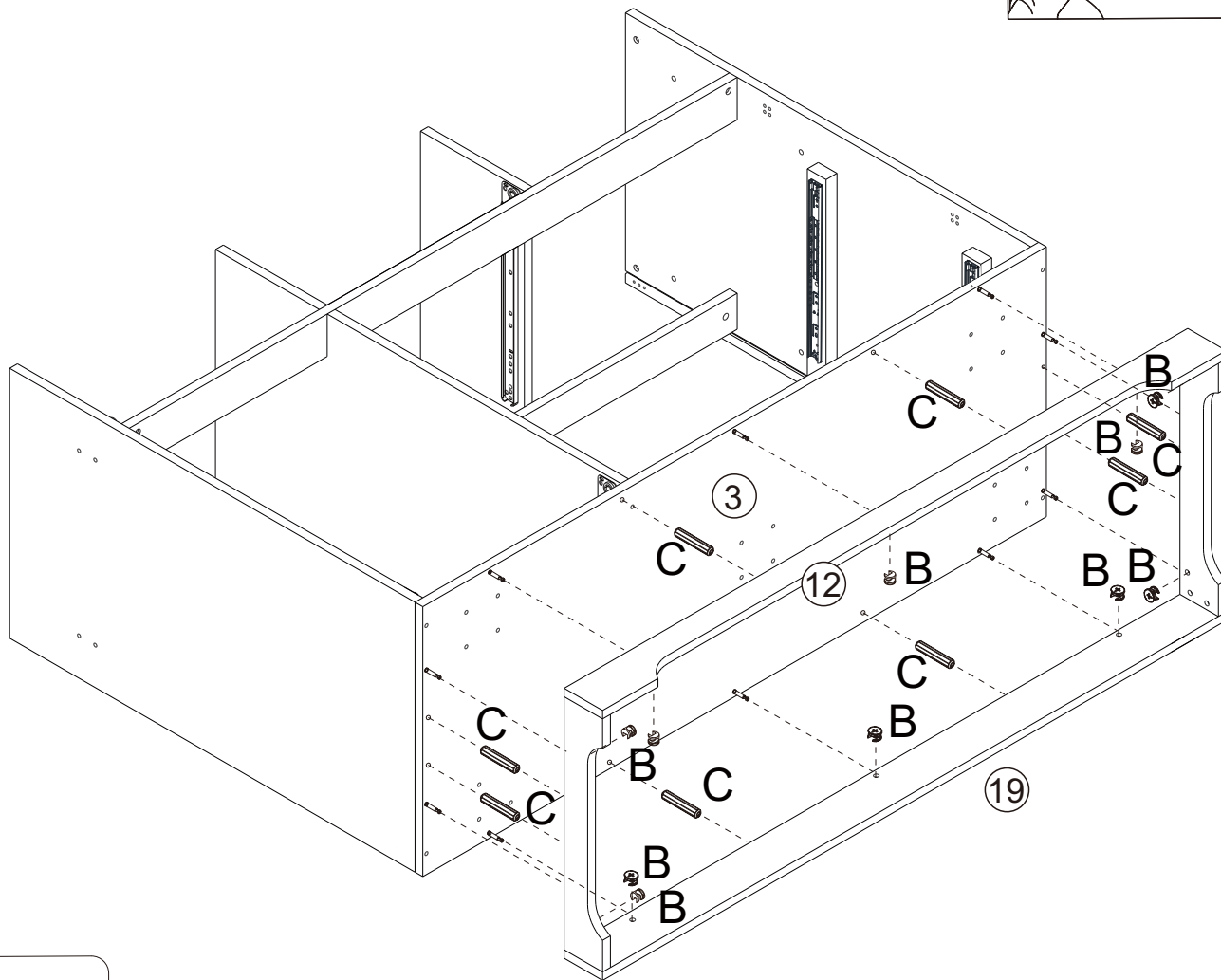

step 9

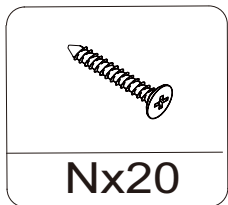
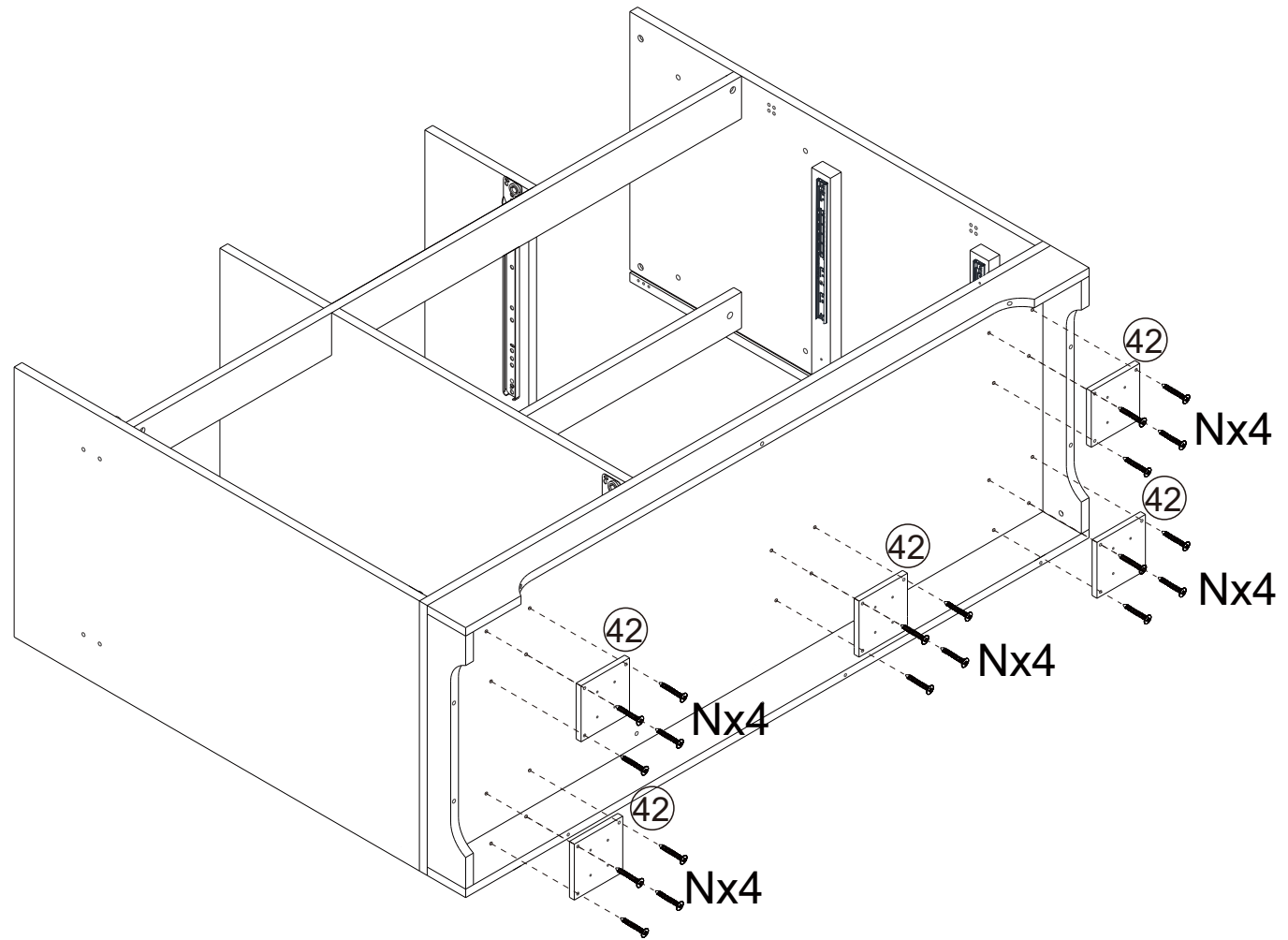

step 10

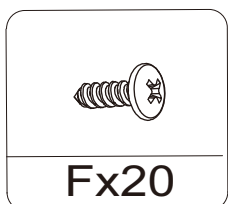
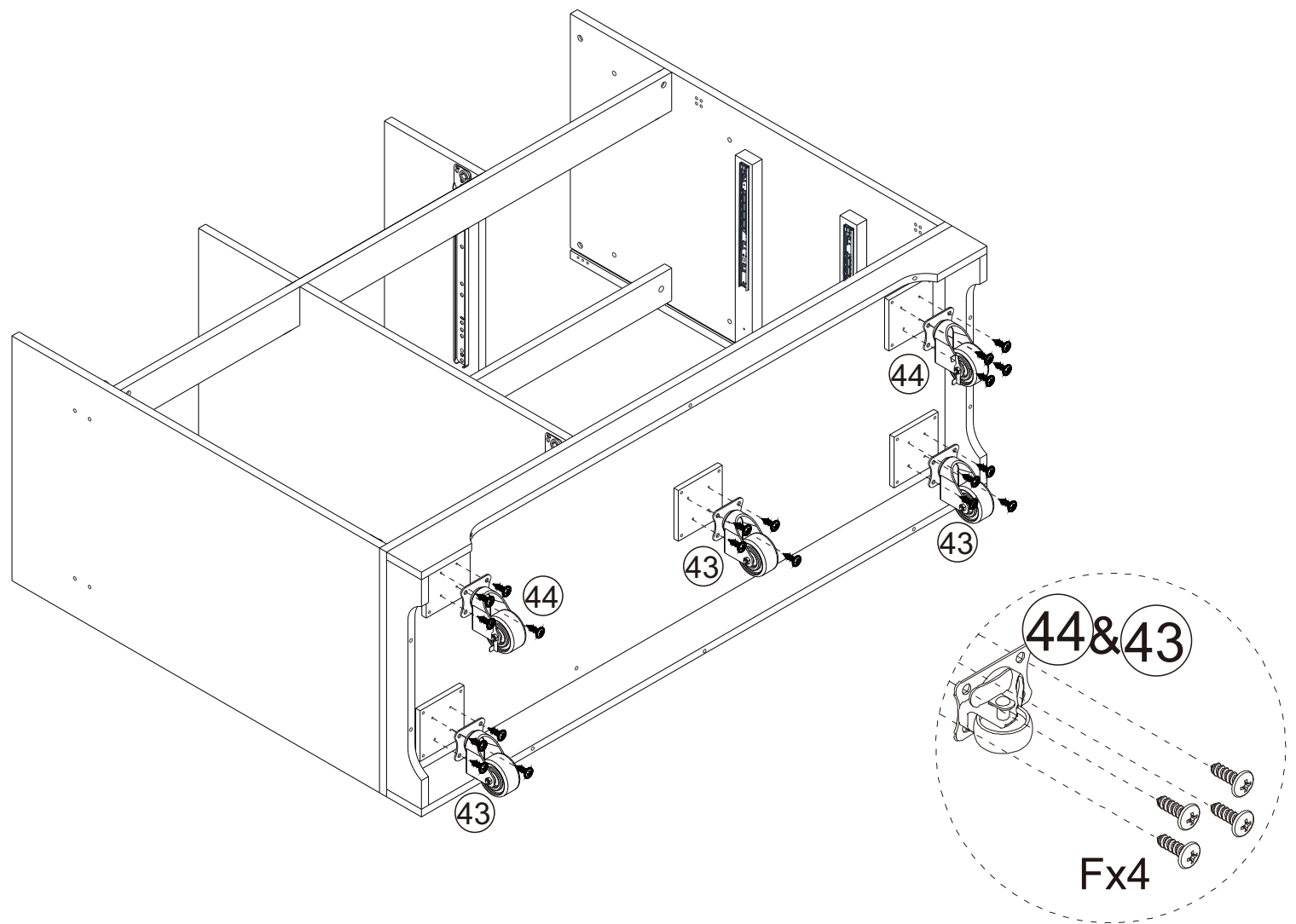

step 11

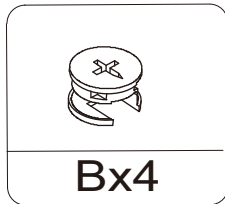
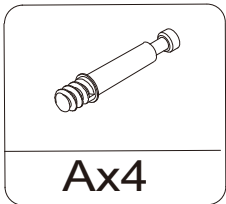
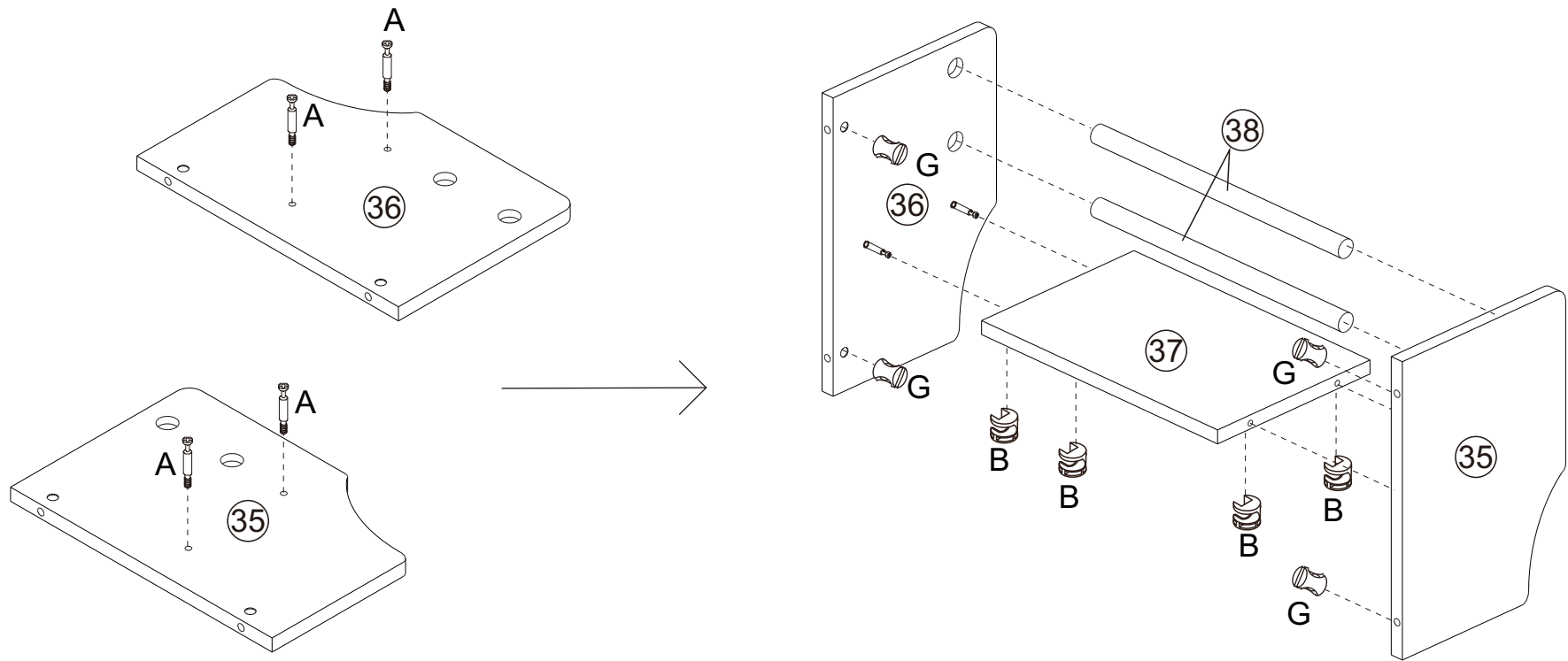

step 12

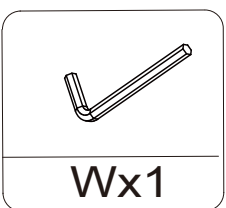
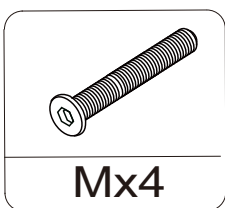
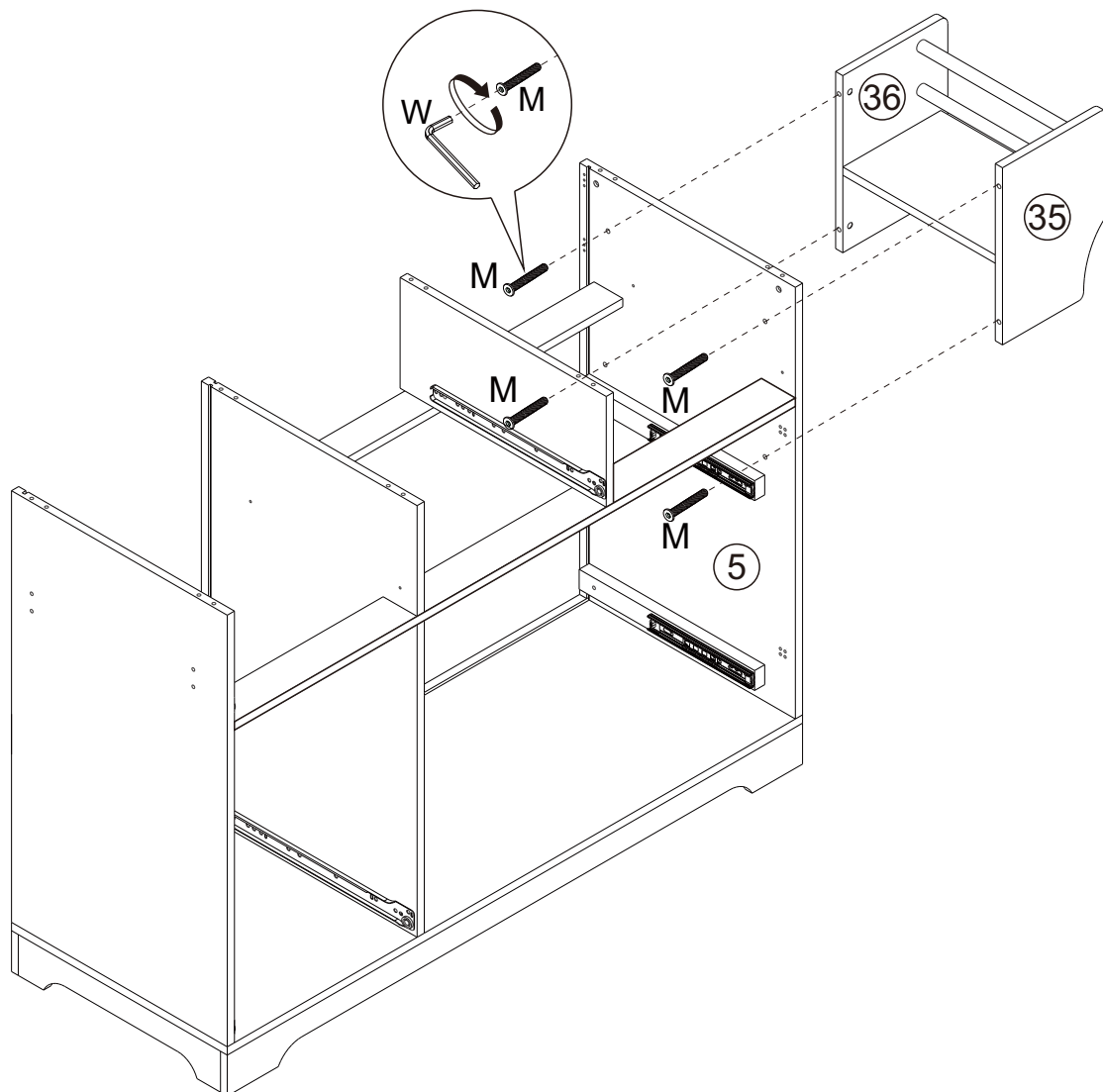

step 13

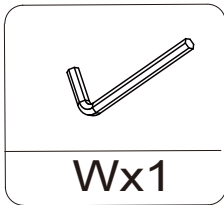
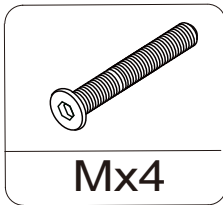
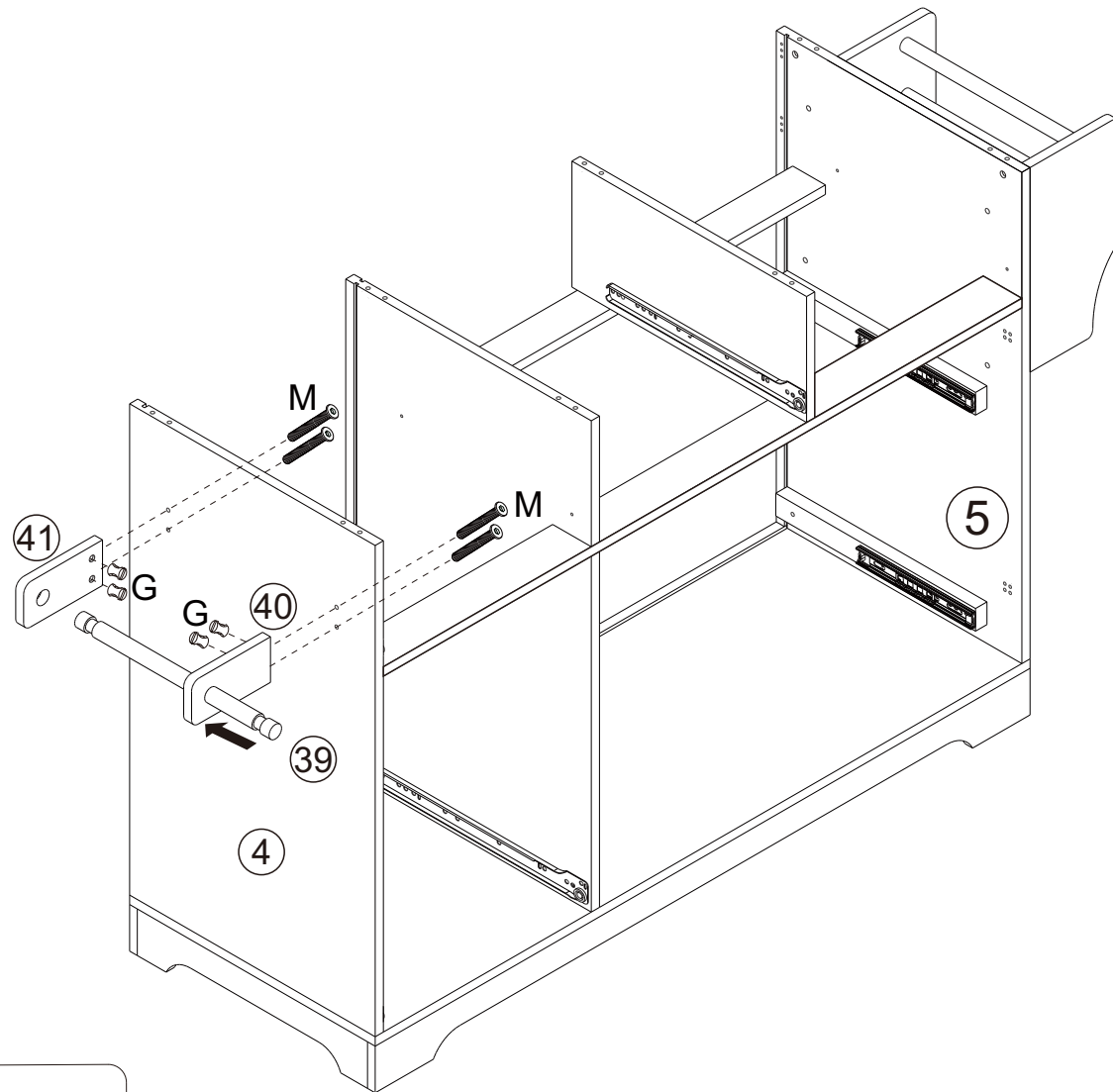
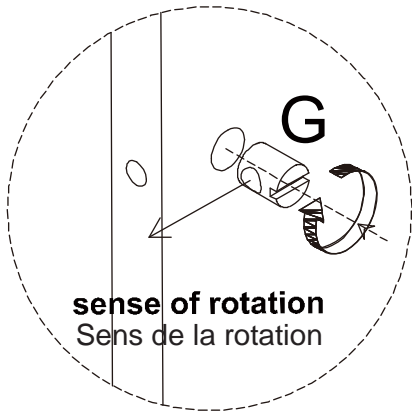

step 14

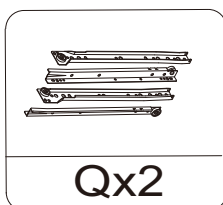
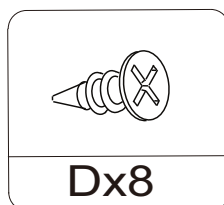
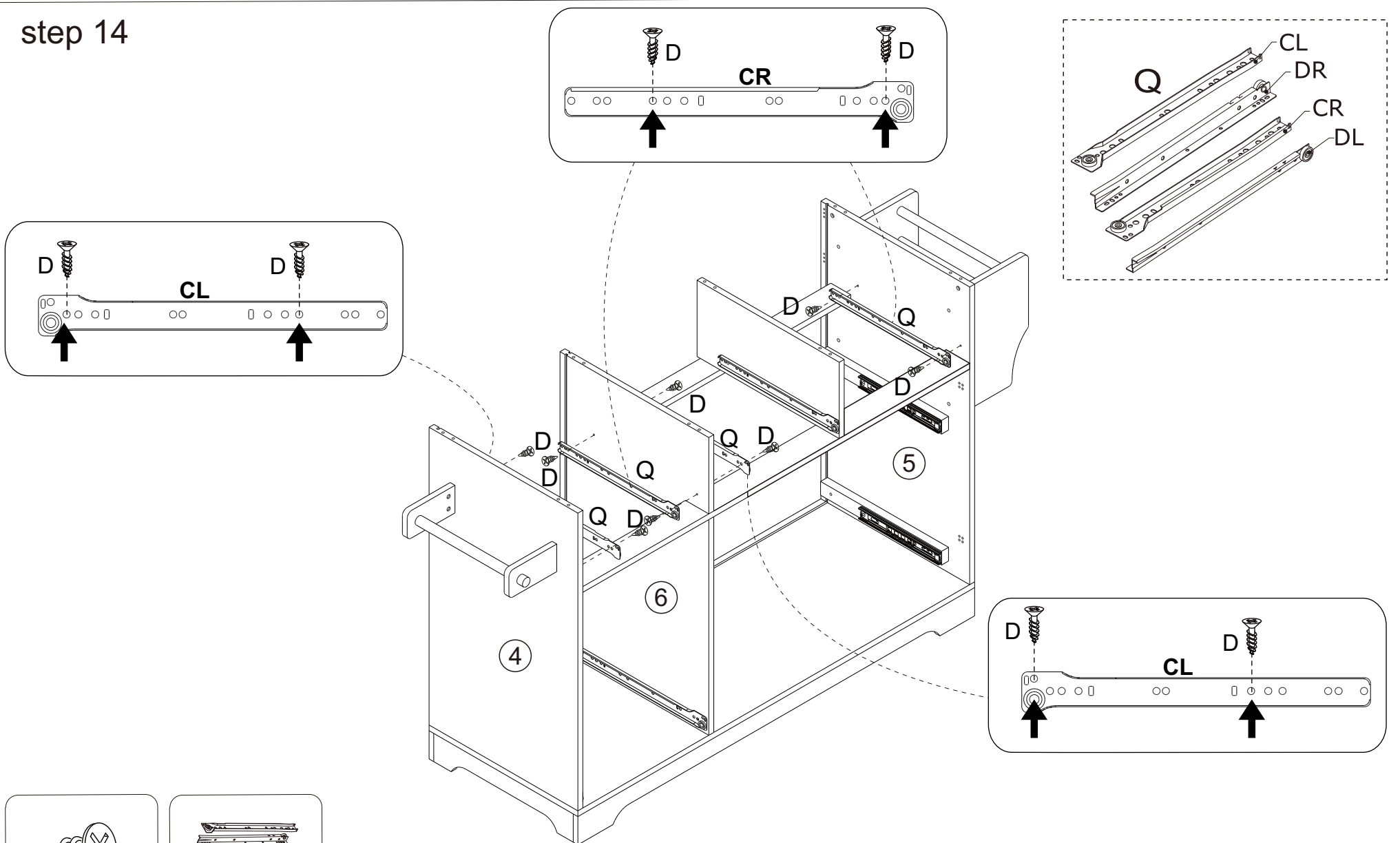

step 15

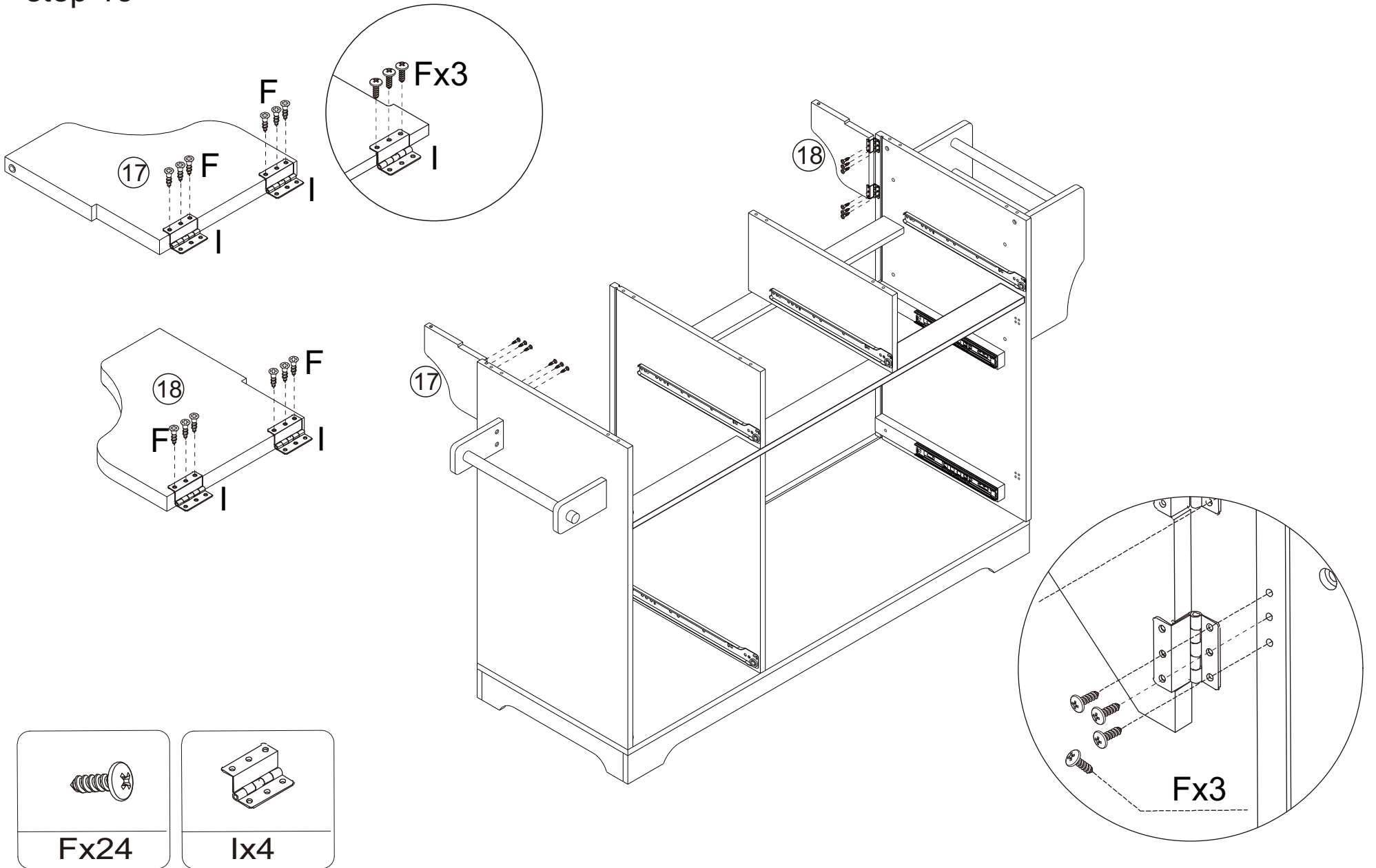

step 16

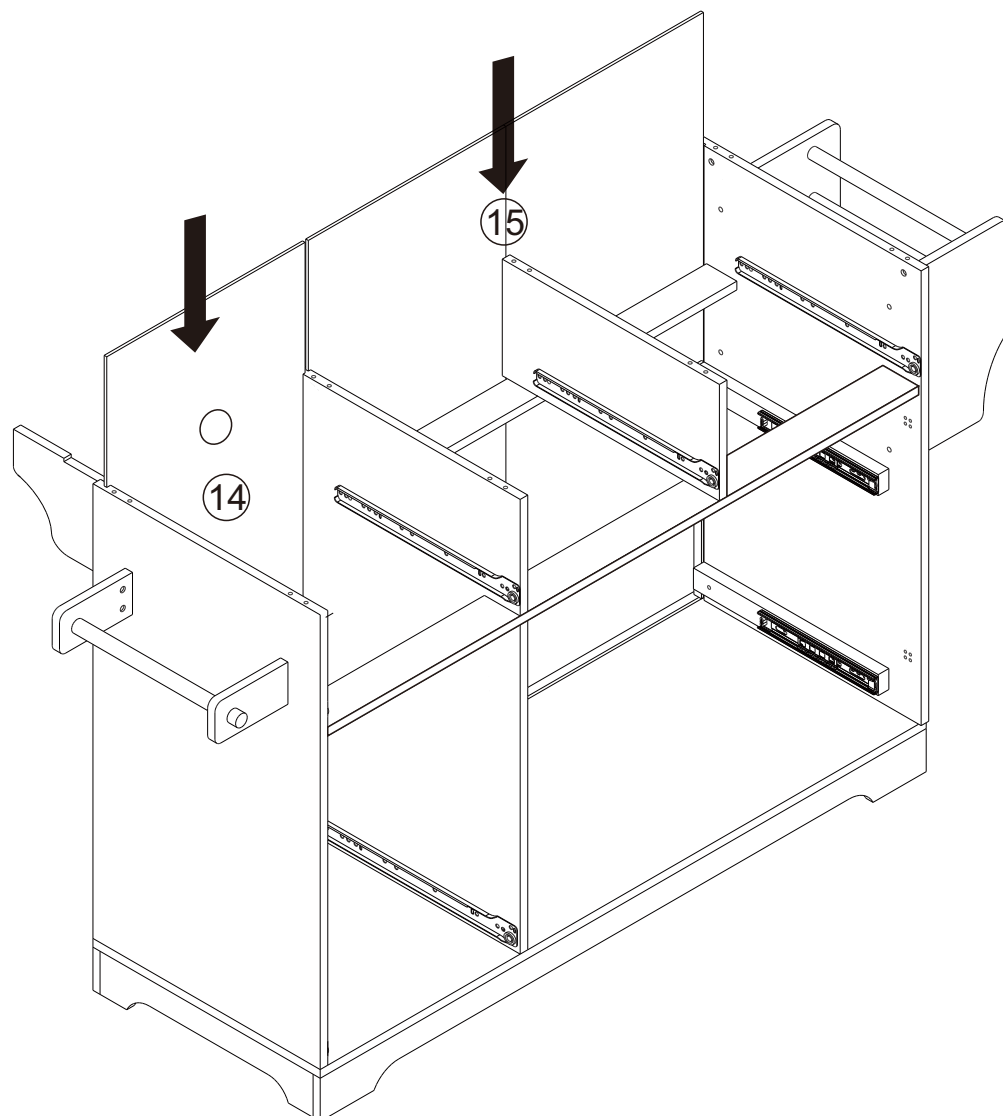

step 17

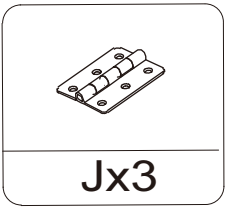
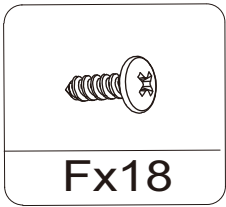
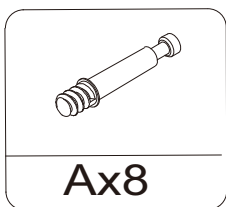
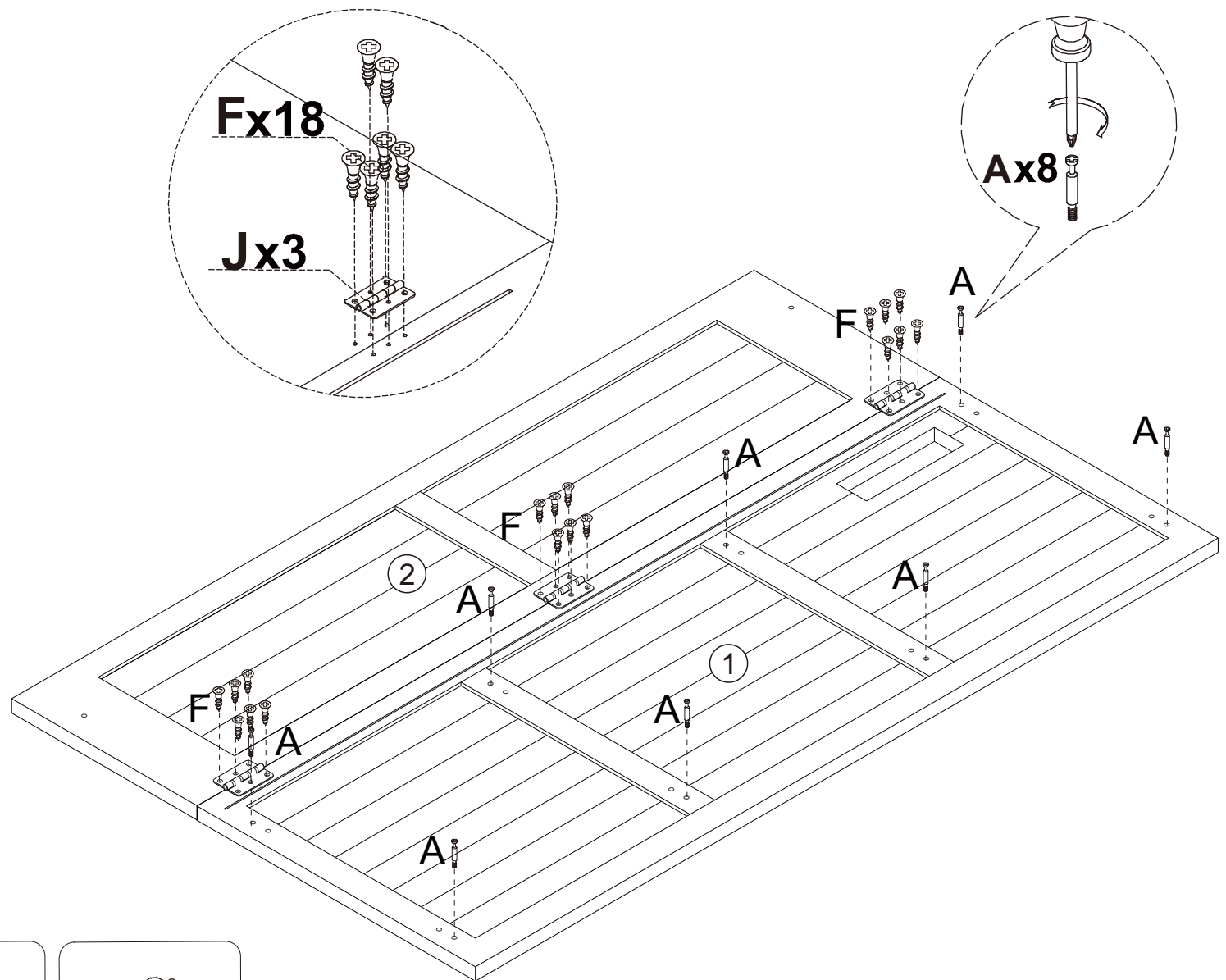

step 18

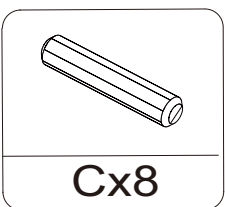
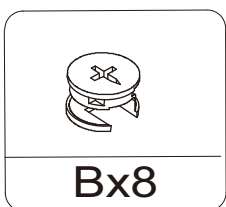
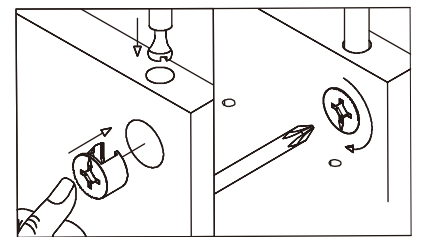
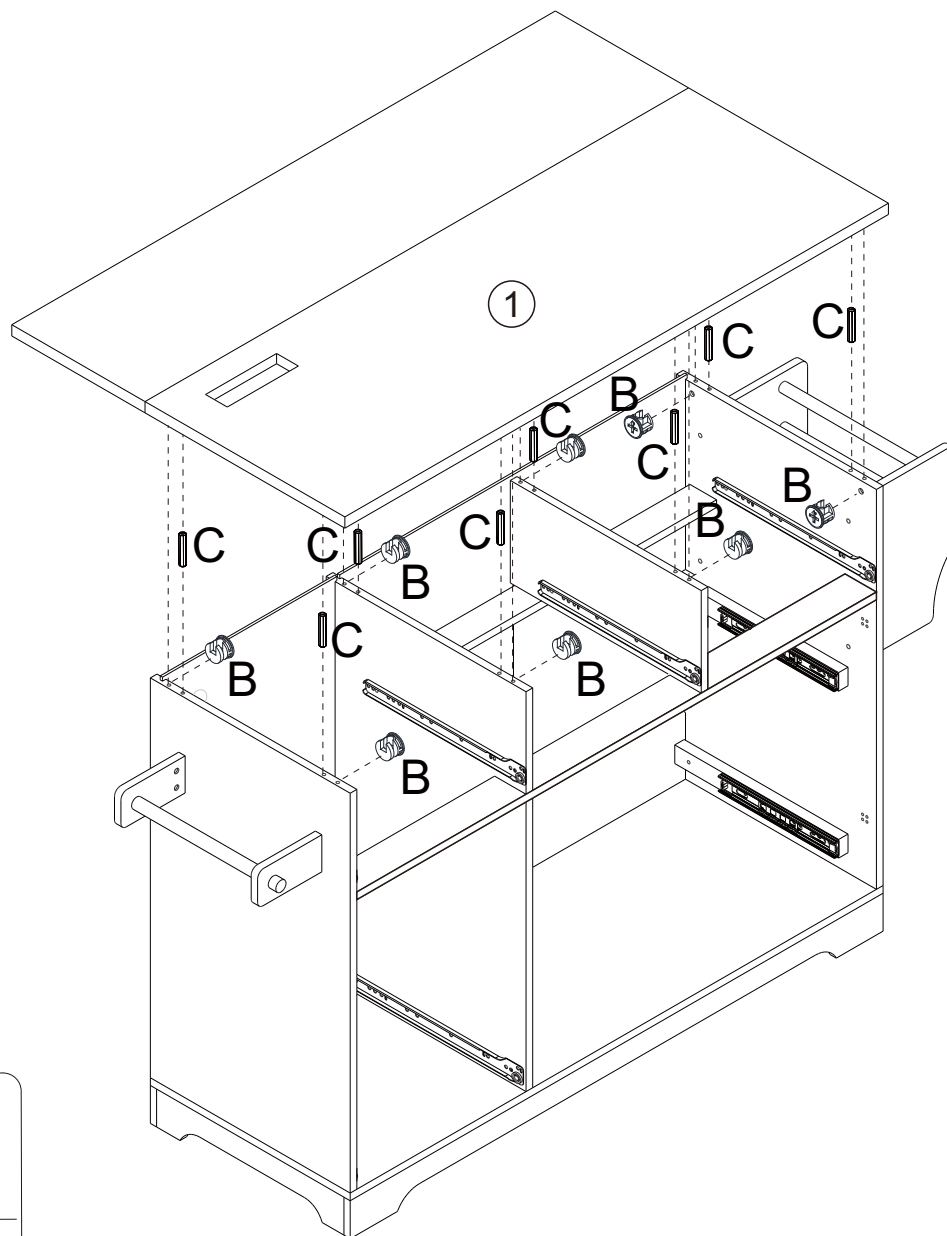

step 19

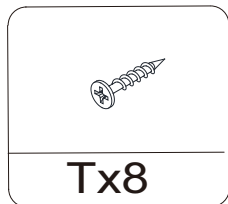
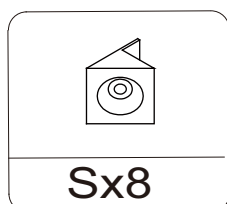
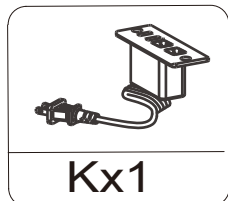
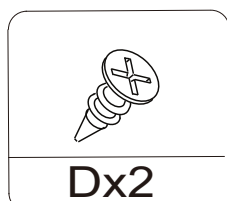
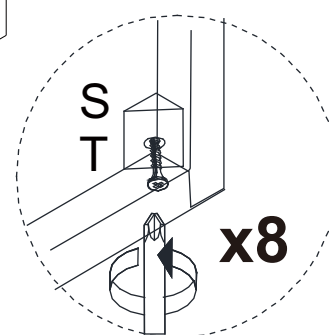
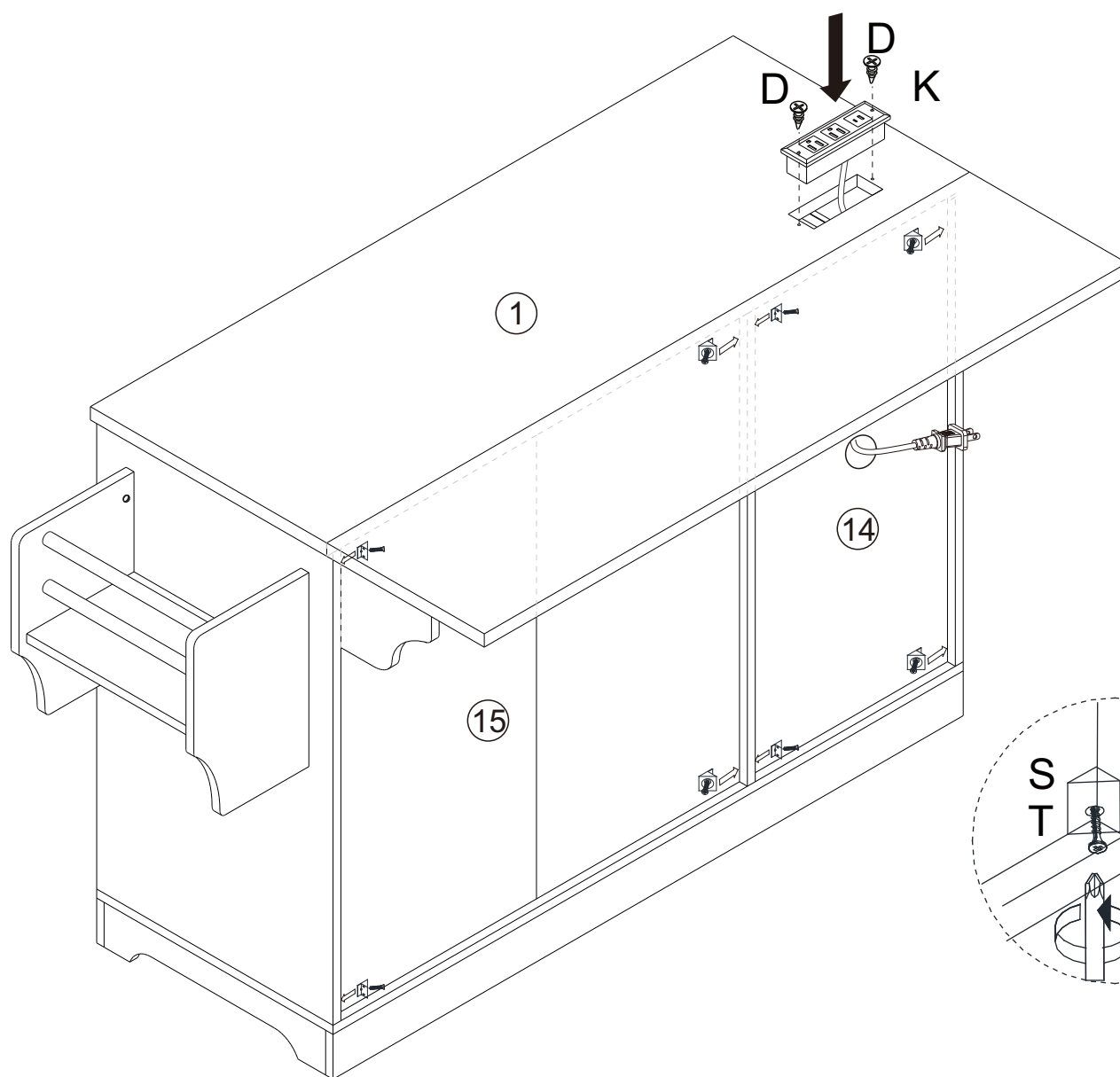

step 20

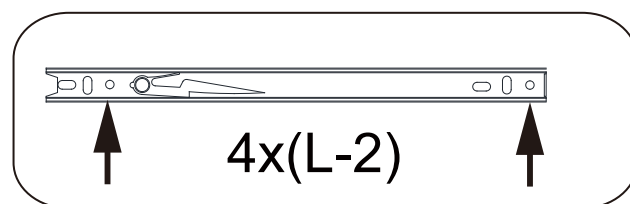
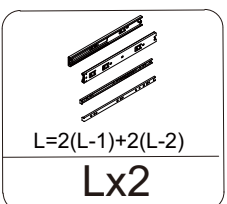
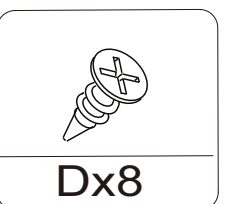
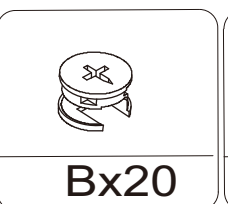
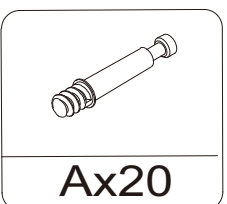
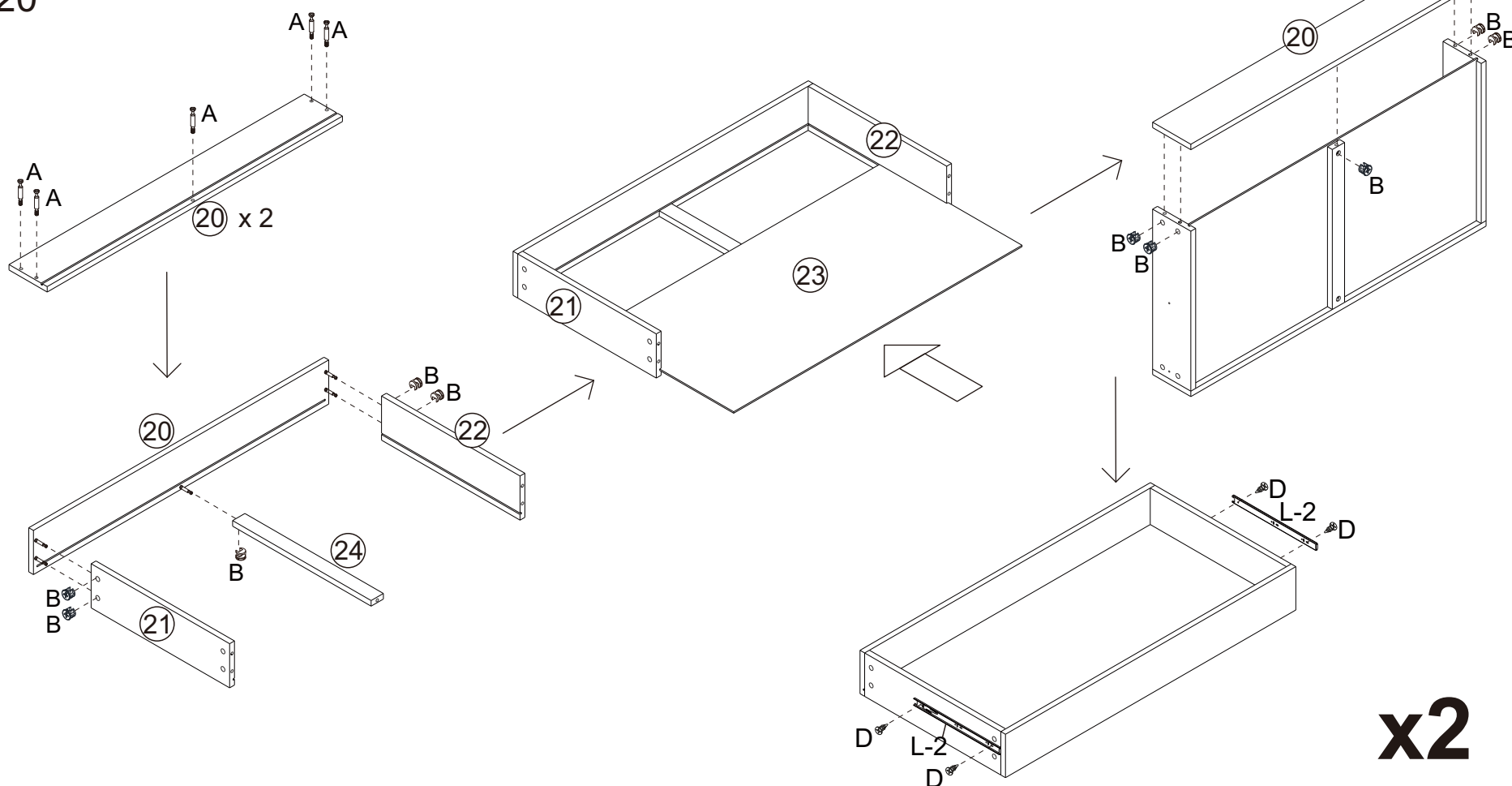

step 21

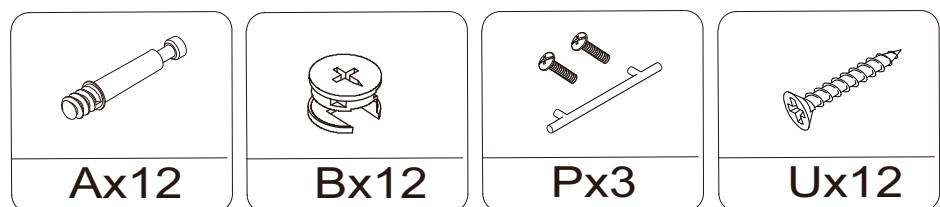
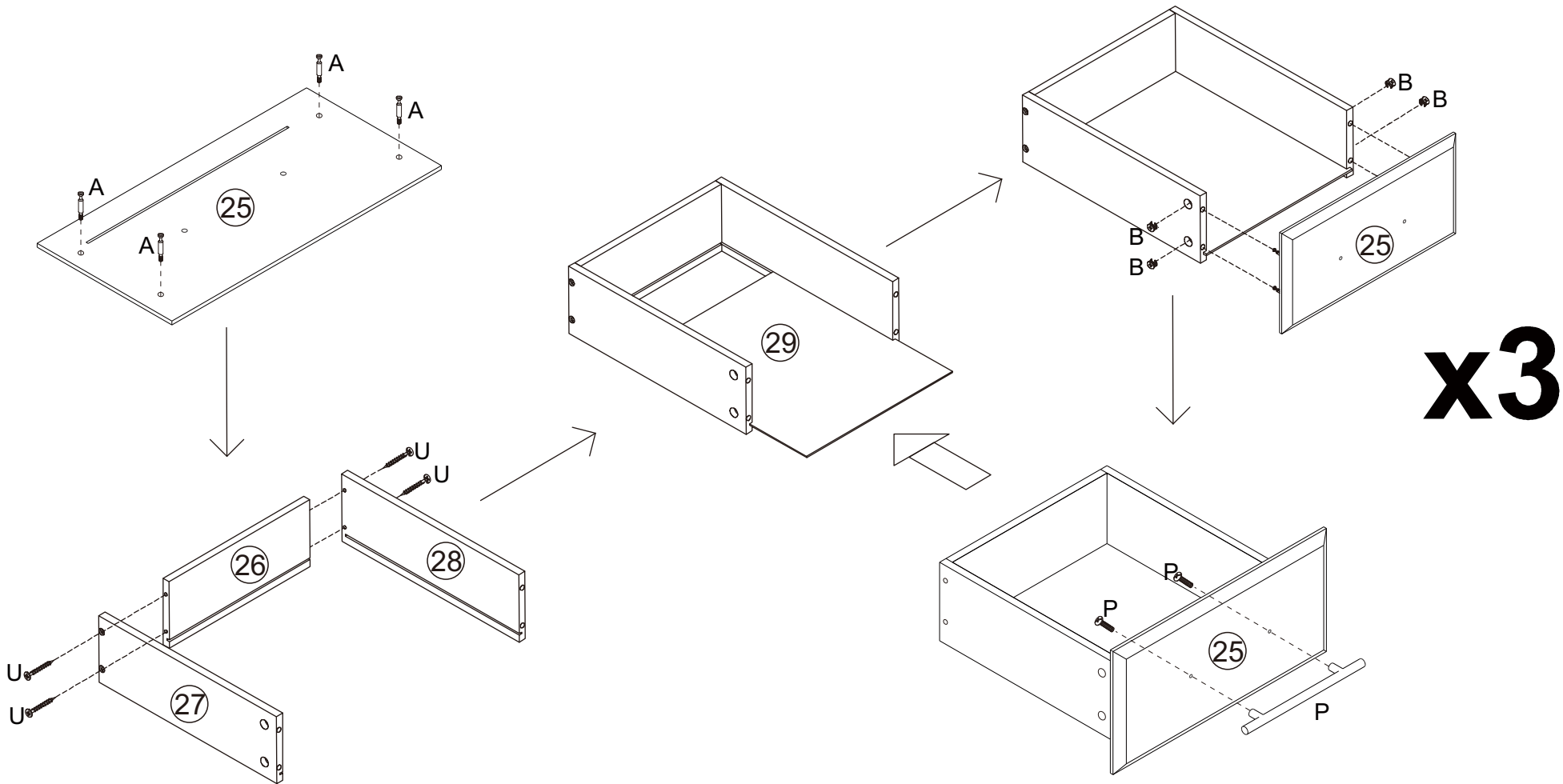

step 22

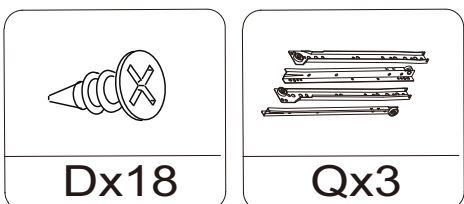
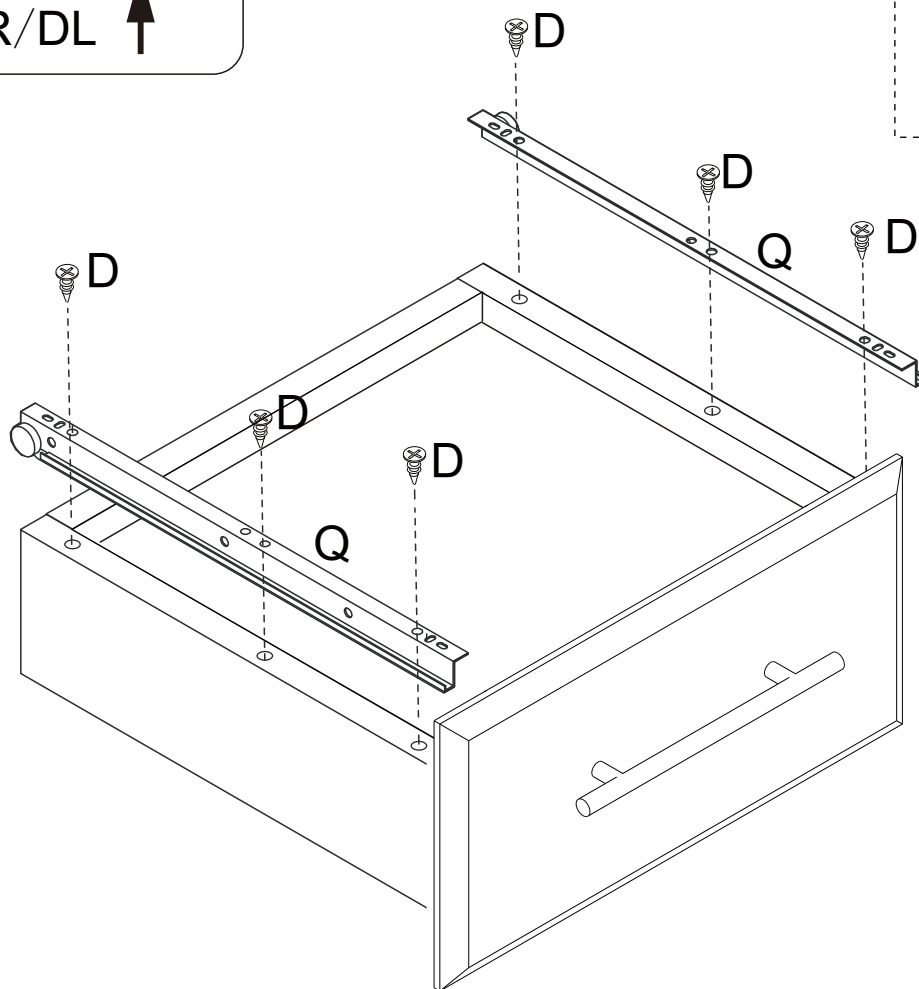
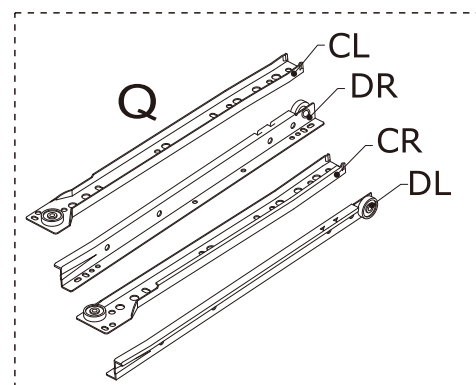
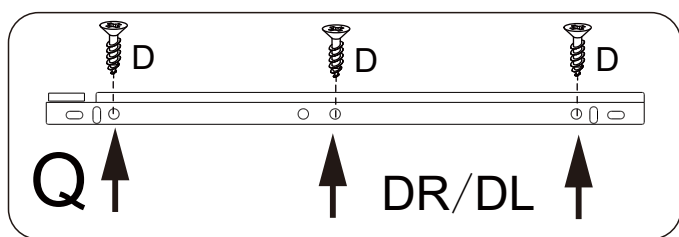

step 23

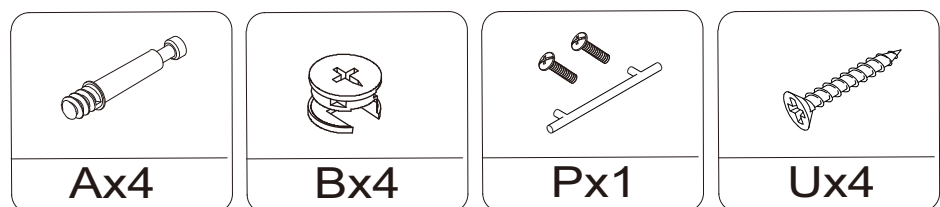
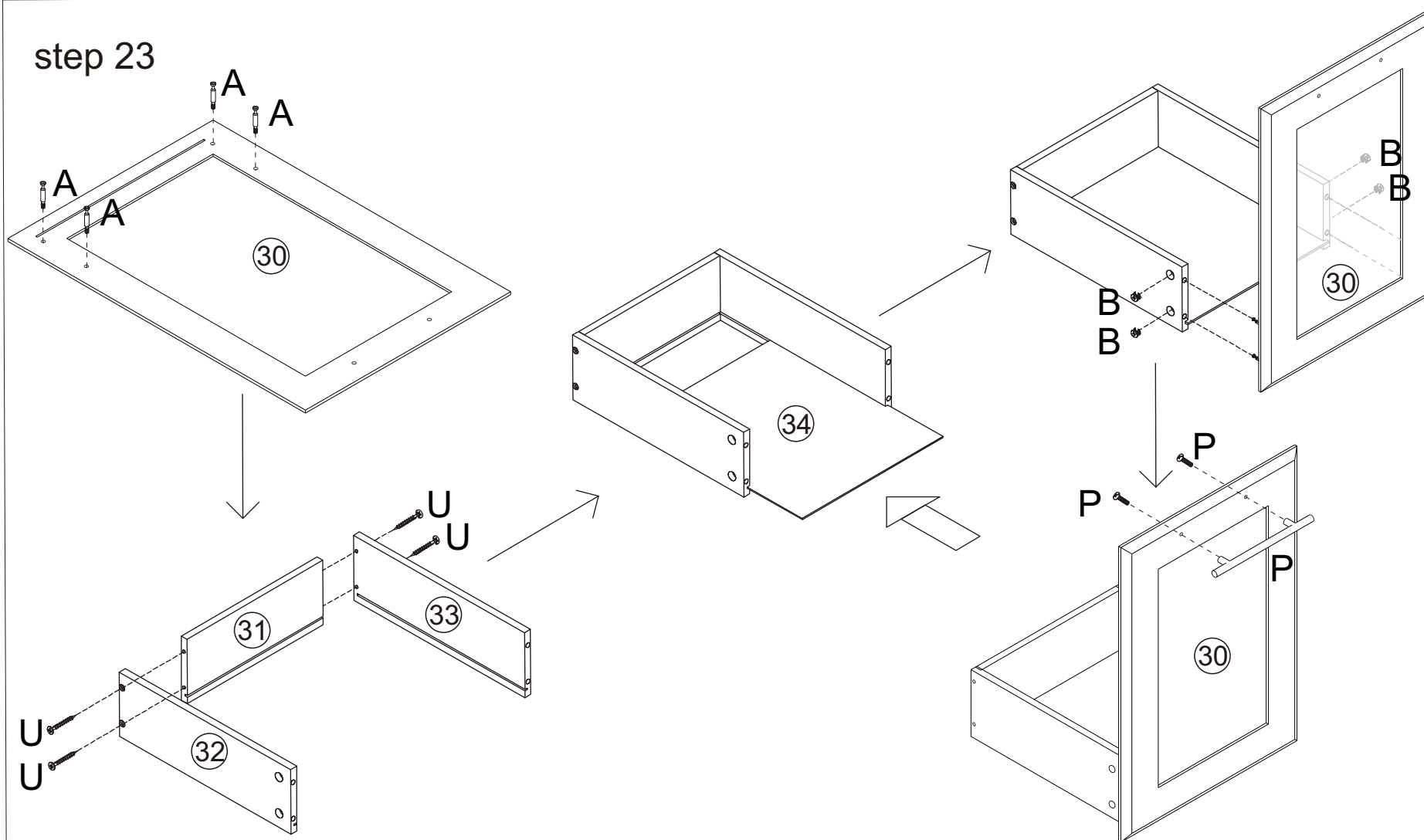

step 24

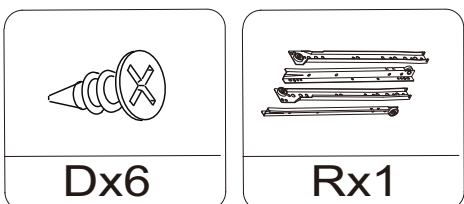
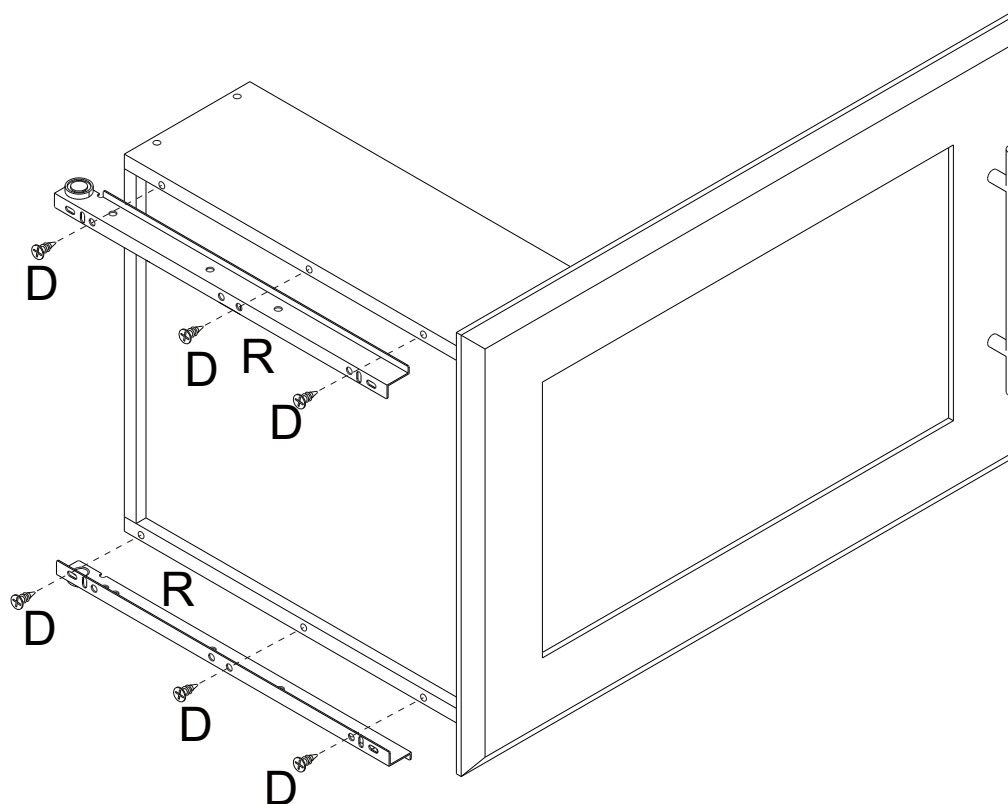
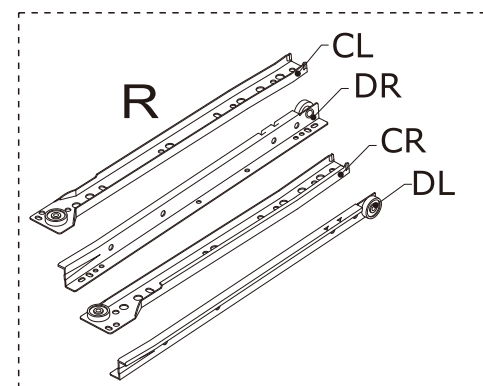
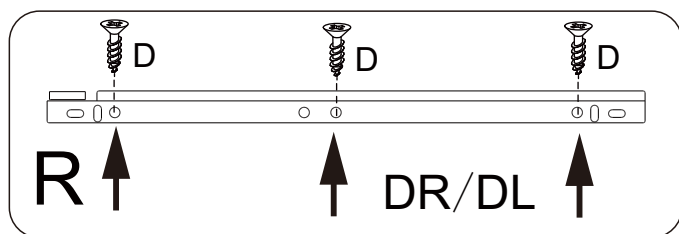

step 25

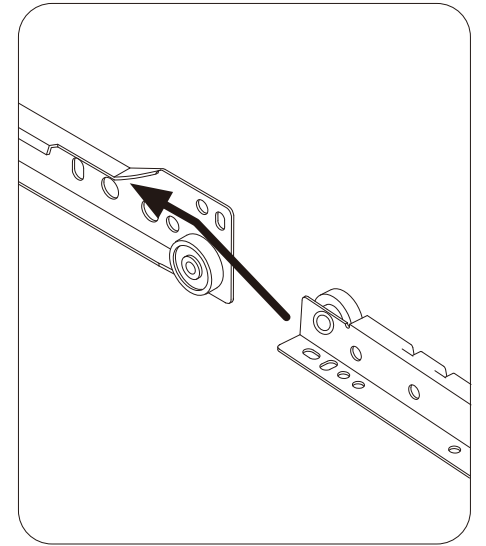
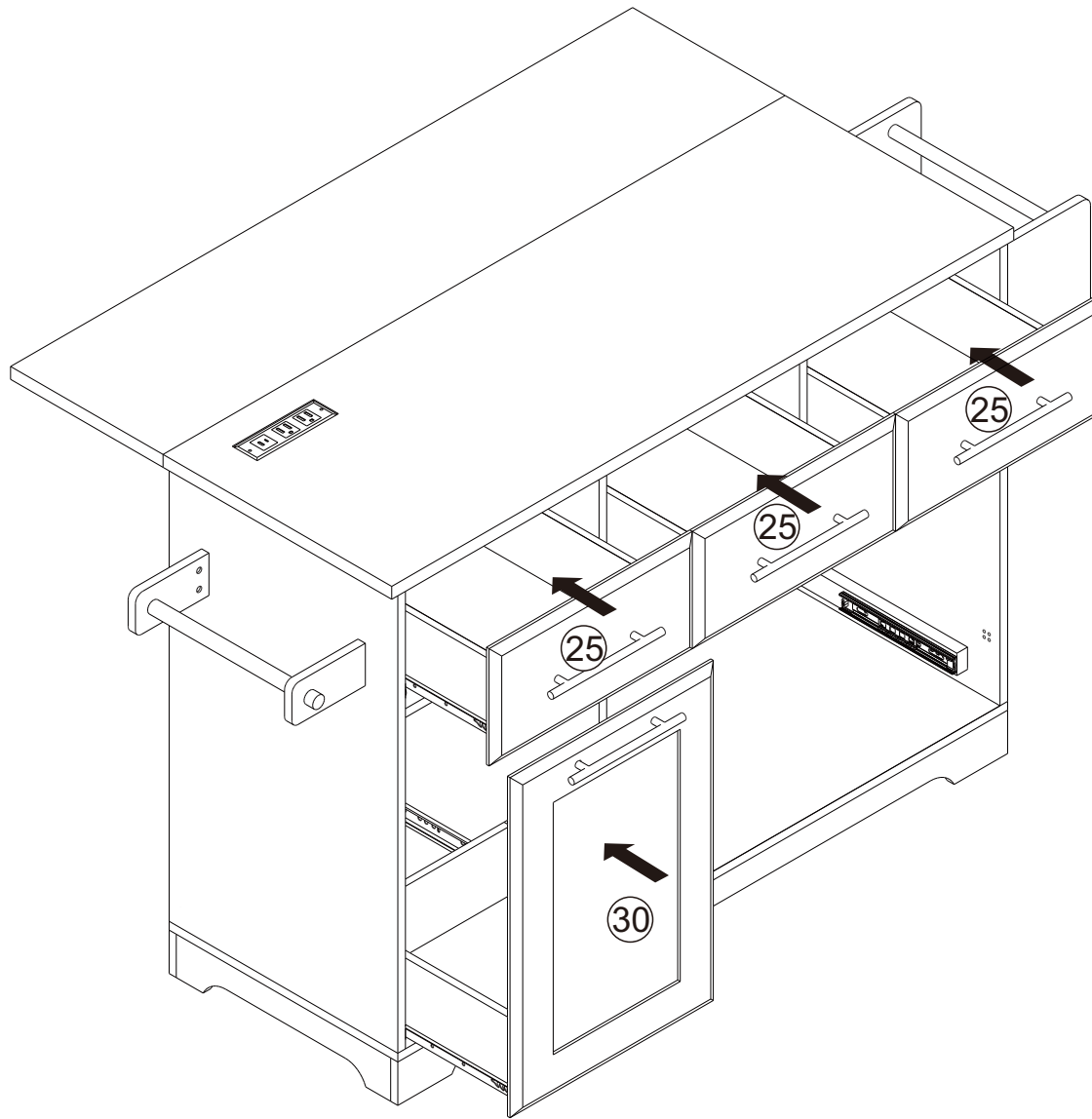

step 26

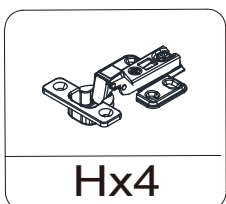
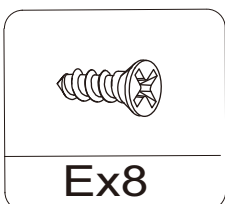
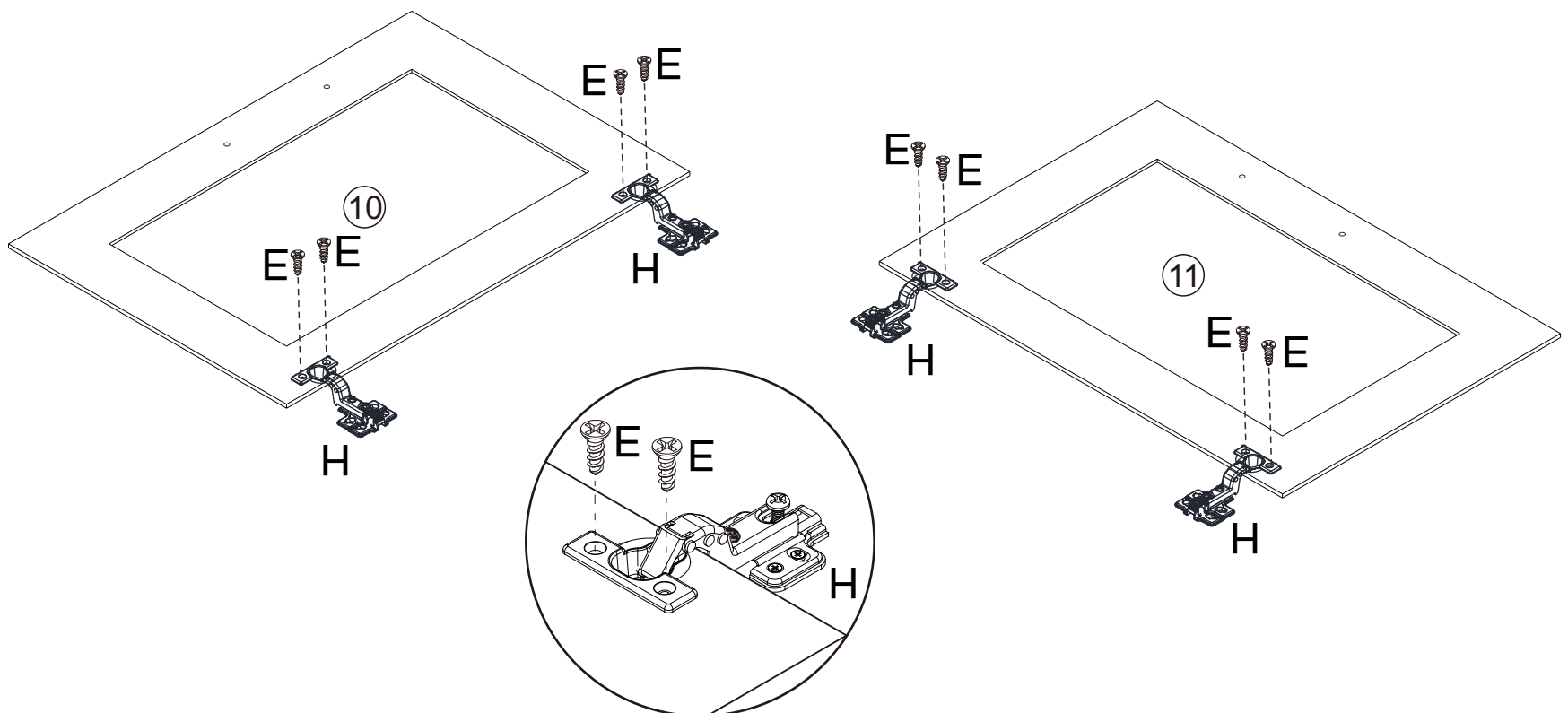

step 27

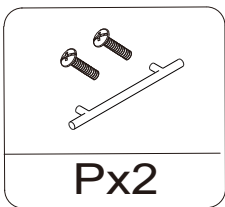
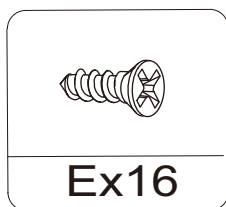
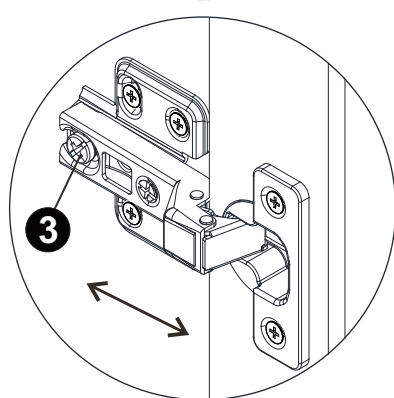
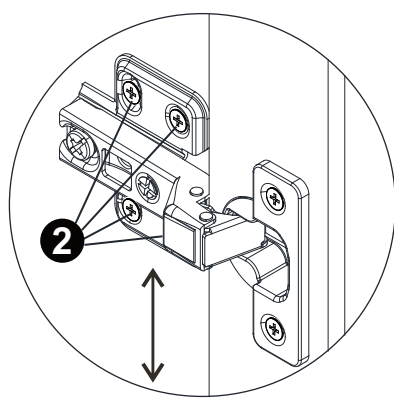
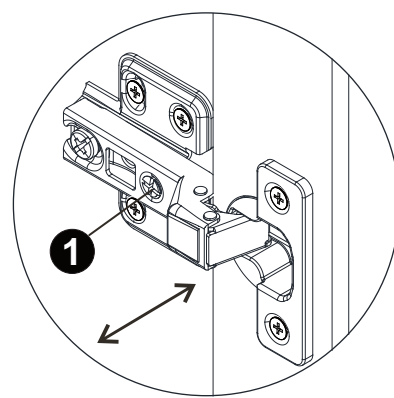
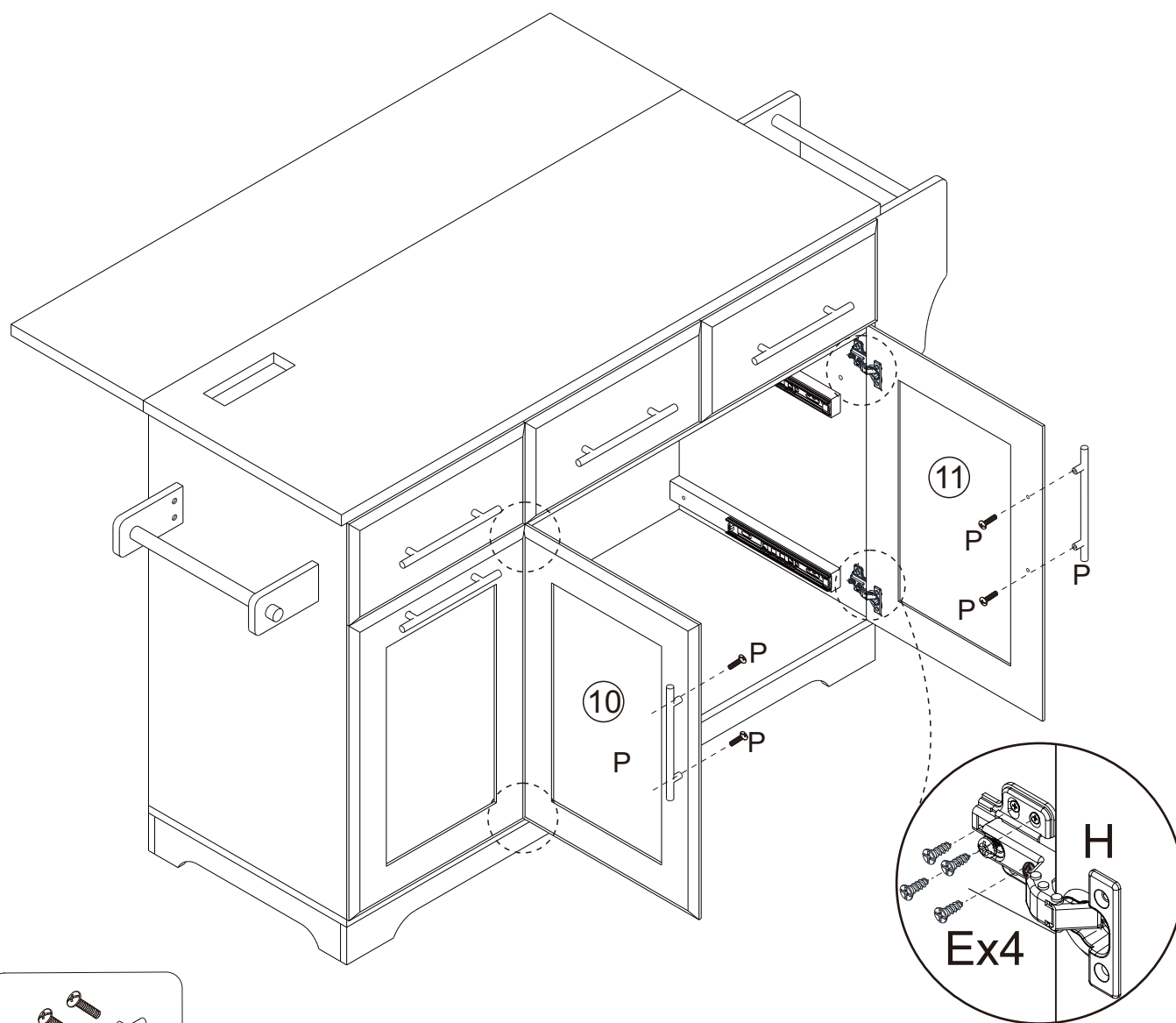

step 28

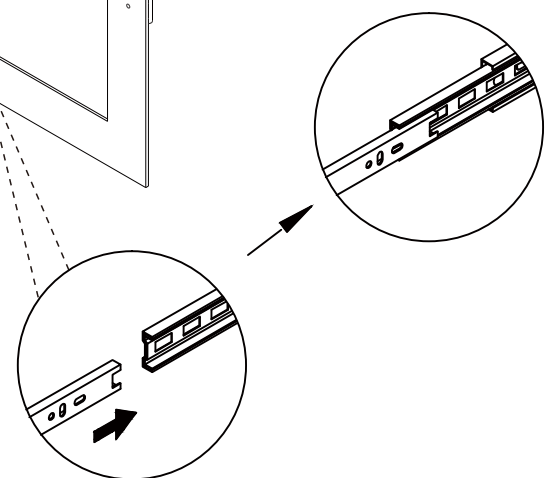
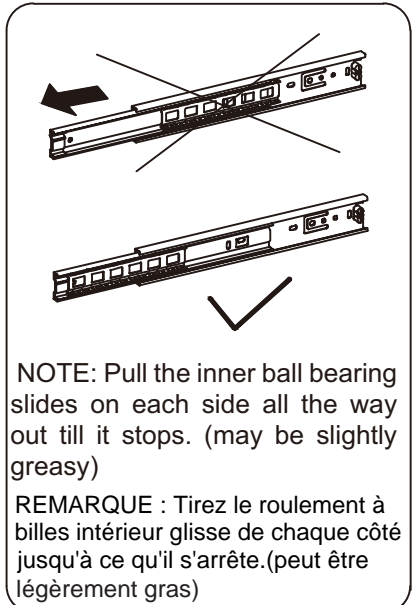
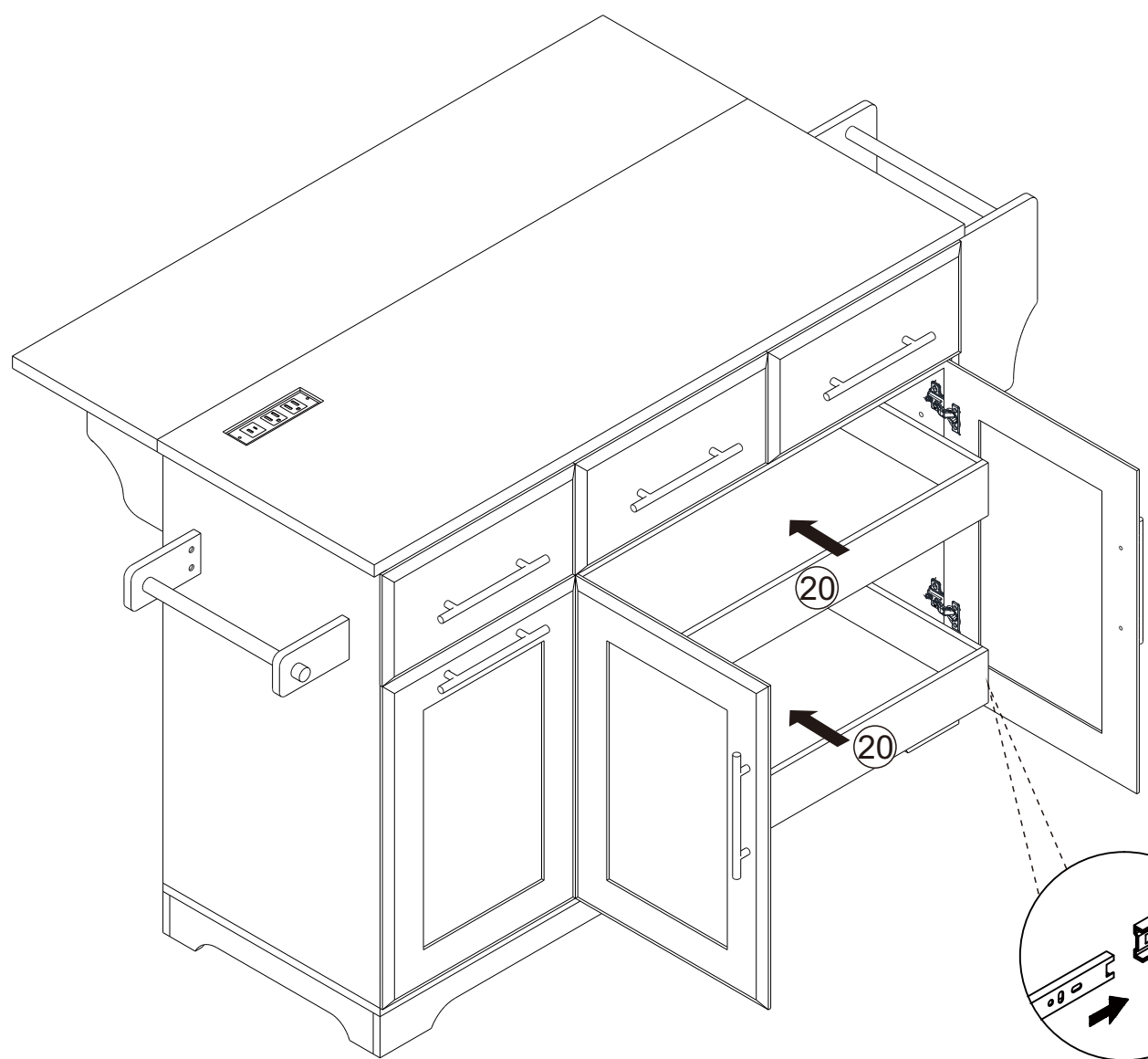

step 29

