

Arched Storage Cabinet / Armoire de rangement arquée

Please keep for future reference
s' il vous plaît garder pour référence future

SKU:N853P387772

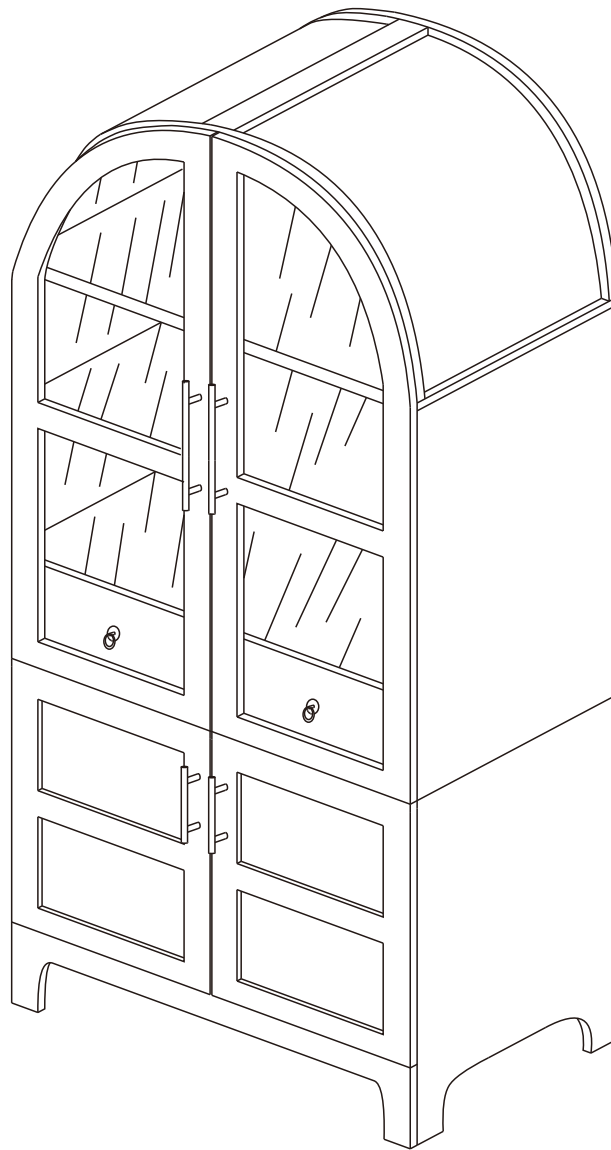

Important - Please read these instructions fully before starting assembly
Important - veuillez lire ces instructions complètement avant de commencer l' assemblage



Safety and Care Advice

Important – Please read these instructions fully before starting assembly

- Check you have all the components and tools listed on the following pages.
- Remove all fittings from the plastic bags and separate them into their groups.
- Keep children and animals away from the work area, small parts could choke if swallowed.
- Make sure you have enough space to layout the parts before starting.

- During assembly do not stand or put weight on the product, this could cause damage.
- Assemble the item as close to its final position (in the same room) as possible.
- Assemble on a soft level surface to avoid damaging the unit or your floor.
- Parts of the assembly will be easier with 2 people.



- To reduce the likelihood of damaging your product please ensure that your power drill is set on a low torque setting.

Care and maintenance

- Only clean using a damp cloth and mild detergent, do not use bleach or abrasive cleaners.
- From time to time check that there are no loose screws on this unit.
- This product should not be discarded with household waste. Take to your local authority waste disposal centre.

Handy Hints

- Assemble all parts and bolts loosely during assembly, only once the product is complete should you fully tighten the bolts
- Regularly check and ensure That all bolts and fittings are tightend properly.

WARNING In order to help prevent overturning – please follow these instructions

To help prevent product toppling over please follow the below steps:-

Use the anti tip stap or wall fixing method provided (if applicable)
Do not allow children to climb or hang on the furniture
Do not open more than one drawer at a time
Do not place heavy items in the top drawers
Do not place heavy items on top of the furniture, unless the furniture has been designed for this purpose

Please note that only the anti tip strap is provided.
You will need to provide wall plugs and screws applicable for your wall type

Conseils de sécurité et d'entretien

Important - veuillez lire ces instructions complètement avant de commencer l'assemblage

- Vérifiez que vous avez tous les composants et outils énumérés sur les pages suivantes.

- Retirez tous les accessoires des sacs en plastique et les séparez

- Gardez les enfants et les animaux de compagnie loin de la zone d'installation, qui peut causer l'étouffement si de petites pièces sont avalées.

- Assurez-vous d'avoir suffisamment d'espace pour mettre en page les pièces avant.

- Ne pas se tenir debout ou appliquer le poids à Le produit pendant l'assemblage. Cela peut causer des dommages.

- Assemblez l'élément le plus près possible de sa position finale (dans la salle de sameroom).

- Assemblez sur un niveau doux Surface pour éviter les dommages À l'unité ou à l'étage.

- Il est plus facile pour deux personnes de se réunir Les parties ensemble.

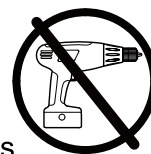

- Pour réduire la probabilité de dommages à votre produit, Assurez-vous que votre perceuse électrique Est réglé sur un réglage de couple faible.

Entretien et entretien

- Nettoyer uniquement à l'aide d'un détergent doux à linge humide, ne pas utiliser d'eau de javel ou de nettoyeurs abrasifs

- Vérifiez les vis desserrées sur Cette unité de temps en temps.

- Ce produit ne doit pas être jeté avec les ordures ménagères emporter au centre d'élimination des déchets de votre collectivité locale

Conseils pratiques

- Assemblez toutes les pièces et boltsloosely pendant l'assemblée, onlyonce que le produit est completeshould vous serrez entièrement les boulons

- Vérifier et assurer régulièrement Que tous les boulons et raccords sont Correctement serré.

Avertissement Afin de prévenir le renversement Veuillez suivre ces instructions

Pour aider à prévenir le renversement du produit, veuillez suivre les étapes suivantes :-

Utilisez la méthode anti-tip stap ou de fixation murale fournie (le cas échéant)
Ne laissez pas les enfants grimper ou accrocher aux meubles
N'ouvrez pas plus d'un tiroir à la fois
Ne placez pas d'objets lourds dans les tiroirs supérieurs
Ne placez pas d'objets lourds sur le dessus des meubles, sauf si les meubles ont été conçus à cet effet

Veuillez noter que seule la courroie anti-pointe est fournie.

Vous devrez fournir des bouchons muraux et des vis applicables pour votre type de mur

Using Camlocks / Utilisation de Camlocks

Step 1 / Étape 1

Connect the male camlock as directed in the assembly instructions using a screwdriver.

Connecter les hommes
Le verrou à came est endommagé
Écrivez des instructions de montage avec screwdriver.

1 DO NOT OVER TIGHTEN.

Ne pas trop serrer.
NE PAS SERRER EXCESSIVEMENT.

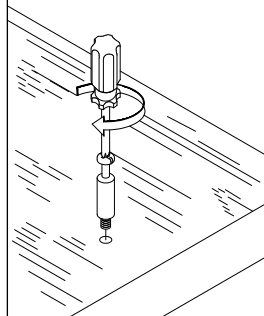

Step 2 / Étape 2

Push the male camlock into the entry hole.

Poussez le verrou à came convexe dans l'orifice d'entrée.

2

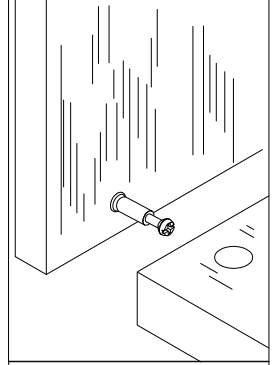

Step 3 / Étape 3

Insert the female camlock as shown in the instruction.
Note: ensure that the arrow on the top of the camlock points towards the entry hole for the male camlock.

Insérer le femle Camlock comme indiqué dans l'Instruction.
Note: assurez-vous que le

3

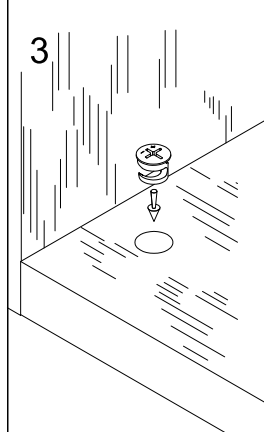

Step 4 / Étape 4

Turn the female camlock clockwise with a screwdriver.
You should feel a click when the camlock is locked in place.
The joint is now secure.

Tournez la femle camlock dans le sens horaire avec un tournevis.
Vous devriez sentir un clic lorsque le camlock est verrouillé en place.
Le joint est maintenant sécurisé.

4

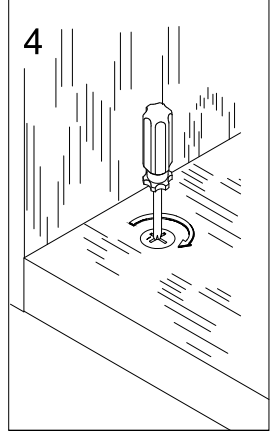

Tools required / Outils nécessaires

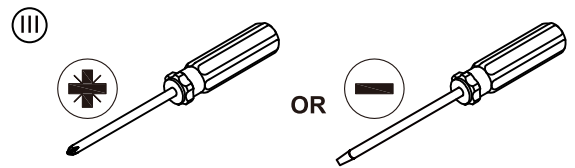
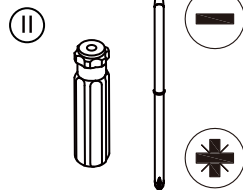
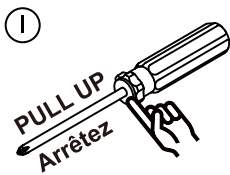

Screwdrivers can be converted to Phillips and Slotted.
Les tournevis peuvent être convertis en Phillips et Slotted.

Ruler - Use this ruler to help correctly identify the screws

Règle - Utilisez cette règle pour aider à identifier correctement les vis

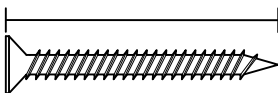
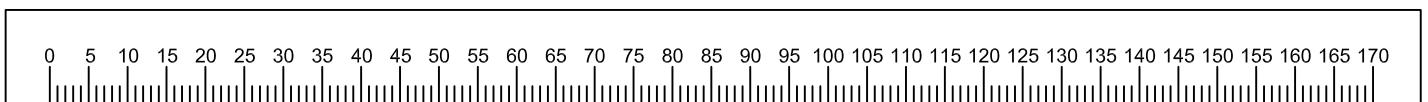

The screws length is measured from the head to the point (35mm screw shown)

La longueur de la vis est mesurée de la tête à la pointe (la vis de 35 mm est représentée)

WARNING:Risk of Shatter Associated with Glass Furniture←

Please note that in rare instances;glass furniture that is damaged by chips or scratches may break.seemingly of its own accord.Damage to the glass(not always visible)can get worse overtime until it reaches a critical point when it may shatter:In the event of damage,this product is designed to shatter into lots of small granular pieces rather than large shards.This is a safety feature to reduce the risk of injury.

To reduce the risk of damage,we recommend the following.

- During assembly do not lay the glass directly onto hard or rough surfaces.Lay the glass on a blanket or cardboard.
- When lifting or moving the product;ask for someone to lend a hand.Trying to move a product on your own can lead to accidents.
- Do not use the furniture if any parts are missing or broken.
- Do not place very hot or very cold items directly on the glass surface;we recommend using a trivet.Extreme temperature differences over small areas can cause damage;which could in turn lead to shattering.
- Do not sit or stand on the glass surface.
- Do not strike the glass with hard or pointed items;or use the glass as a chopping surface.←
- Do not drag rough or heavy objects over the top of the glass.

AVERTISSEMENT: Risque d'éclatement associé aux meubles en verre

Veillez noter que dans de rares cas, les meubles en verre endommagés par des éclats ou des rayures peuvent se briser, apparemment de leur propre gré. Les dommages au verre (pas toujours visibles)

peuvent s'aggraver avec le temps jusqu'à ce qu'ils atteignent un point critique où ils peuvent se briser. En cas de dommages, ce produit est conçu pour se briser en lots de petits morceaux granuleux plutôt qu'en gros éclats, ce qui est un dispositif de sécurité pour réduire les risques de blessures.

Pour réduire le risque de dommages, nous recommandons ce qui suit:

- Lors du montage, ne posez pas le verre directement sur des surfaces dures ou rugueuses, posez le verre sur une couverture ou un carton.
- Lorsque vous soulevez ou déplacez le produit, demandez à quelqu'un de vous aider car essayer de déplacer un produit par vous-même peut entraîner des accidents.
- N'utilisez pas les meubles si des pièces sont manquantes ou cassées.
- Ne placez pas d'objets très chauds ou très froids directement sur la surface en verre, nous vous recommandons d'utiliser un dessous de plat.
- Ne vous asseyez pas et ne vous tenez pas debout sur la surface en verre.
- Ne heurtez pas le verre avec des objets durs ou pointus, et n'utilisez pas le verre comme surface de coupe.
- Ne faites pas glisser d'objets rugueux ou lourds sur le dessus de la vitre.

Assembly Instructions / Instructions de montage

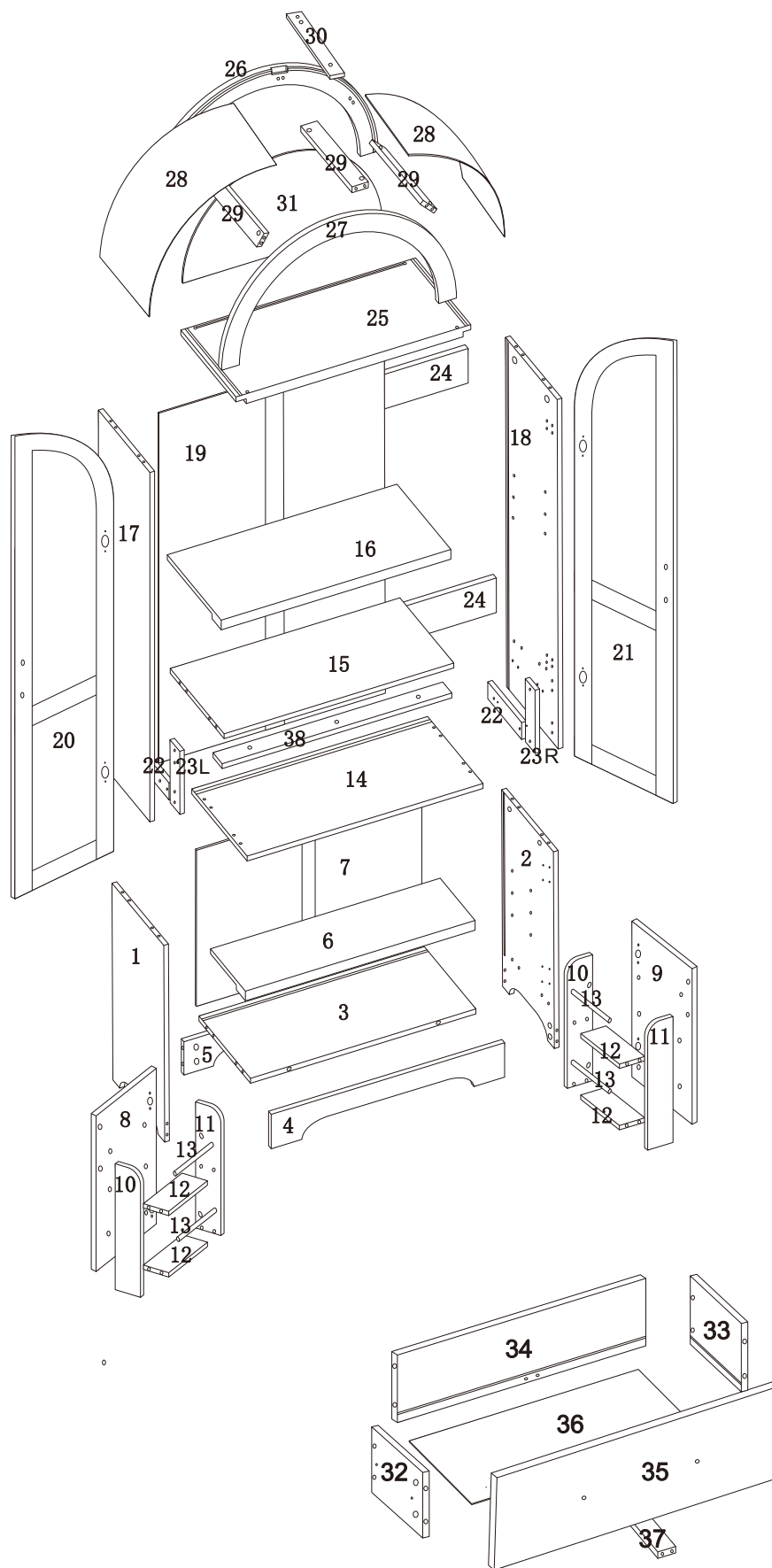











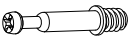

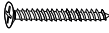







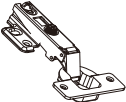

Components - Composants

Please check you have all the panels listed below













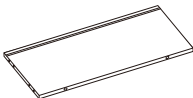
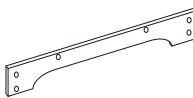
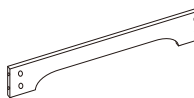
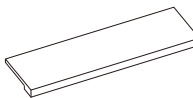
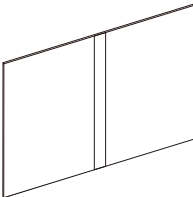

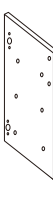

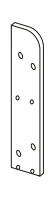

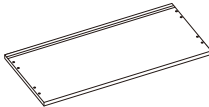
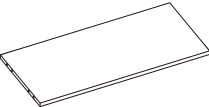
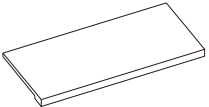

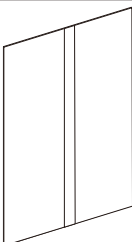

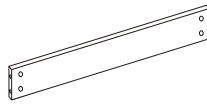

Veuillez vérifier que vous avez tous les panneaux énumérés ci - dessous

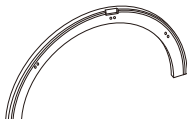
Note: The quantitie below are the correct amount to complete the assembly. In some cases more fittings may be supplied than are required.

Remarque: les quantités suivantes sont les quantités correctes pour l'assemblage terminé. Dans certains cas, plus d'accessoires que nécessaire peuvent être fournis.

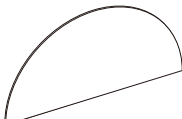
 A: 69pcs	 B: 69pcs	 $\varnothing 5 \times 40 \text{mm}$ C: 8pcs	 $\varnothing 3 \times 12 \text{mm}$ D: 10pcs	 E: 2pcs	 $\varnothing 4 \times 15 \text{mm}$ F: 2pcs	
 G: 2pcs	 $\varnothing 4 \times 25 \text{mm}$ H: 8pcs	 I: 8pcs	 $\varnothing 3 \times 16 \text{mm}$ J: 8pcs	 $\varnothing 6 \times 30 \text{mm}$ K: 31pcs	 $\varnothing 4 \times 30 \text{mm}$ L: 6pcs	 M: 8pcs
 $\varnothing 4 \times 14 \text{mm}$ N: 48pcs	 O: 8pcs	 P: 2pcs	 Q: 1pc	 R: 2pcs	 $\varnothing 6 \times 20 \text{mm}$ S: 8pcs	 $\varnothing 4 \times 18 \text{mm}$ T: 11pcs
 U: 1pc	 $\varnothing 4 \times 25 \text{mm}$ V: 2pcs					

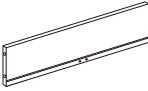
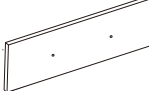
Assembly Instructions / Instructions de montage

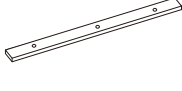
						
1: 1pc	2: 1pc	3: 1pc	4: 1pc	5: 1pc	6: 1pc	
						
7: 1pc	8: 1pc	9: 1pc	10: 2pcs	11: 2pcs	12: 4pcs	
						
13: 4pcs	14: 1pc	15: 1pcs	16: 1pc	17: 1pc	18: 1pc	
						
19: 1pc	20: 1pc	21: 1pc	22: 2pcs	23: 2pcs	24: 2pcs	
						
25: 1pc	26: 1pc	27: 1pc	28: 2pcs	29: 3pcs	30: 1pc	31: 1pc
						
32: 1pc	33: 1pc	34: 1pc	35: 1pc	36: 1pc	37: 1pc	38: 1pc

Step 1
Étape 1

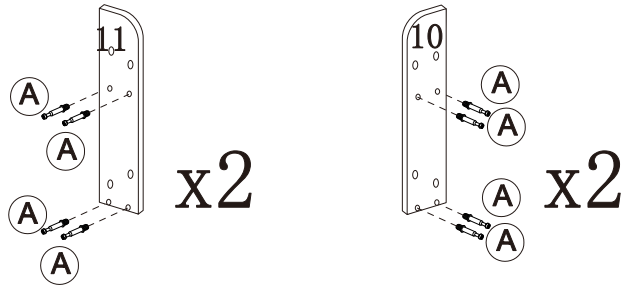
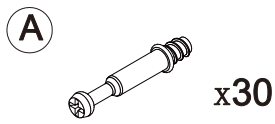
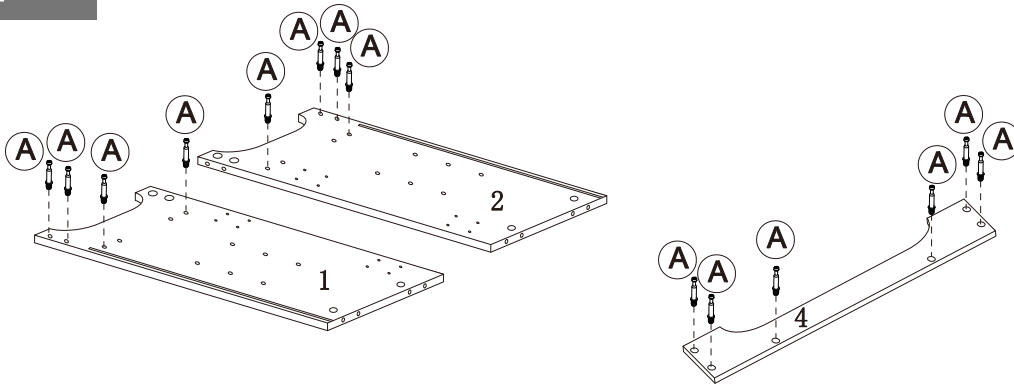

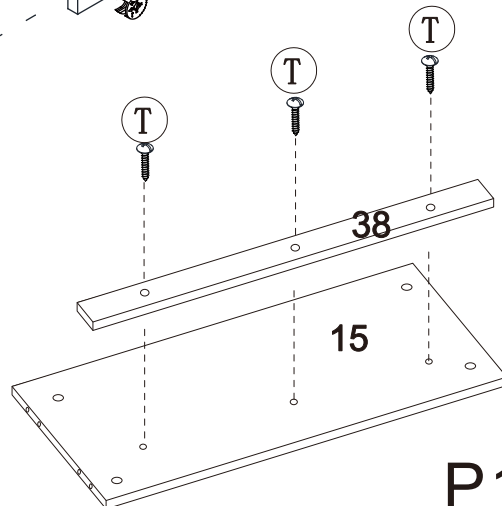
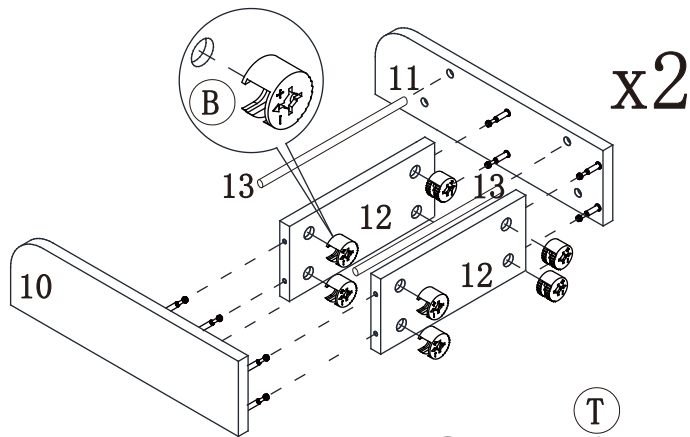

Step 2
Étape 2



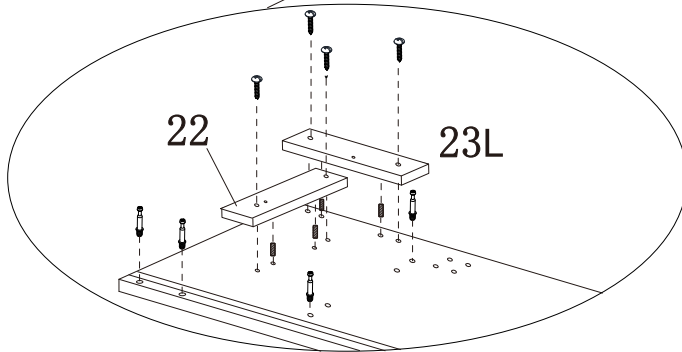
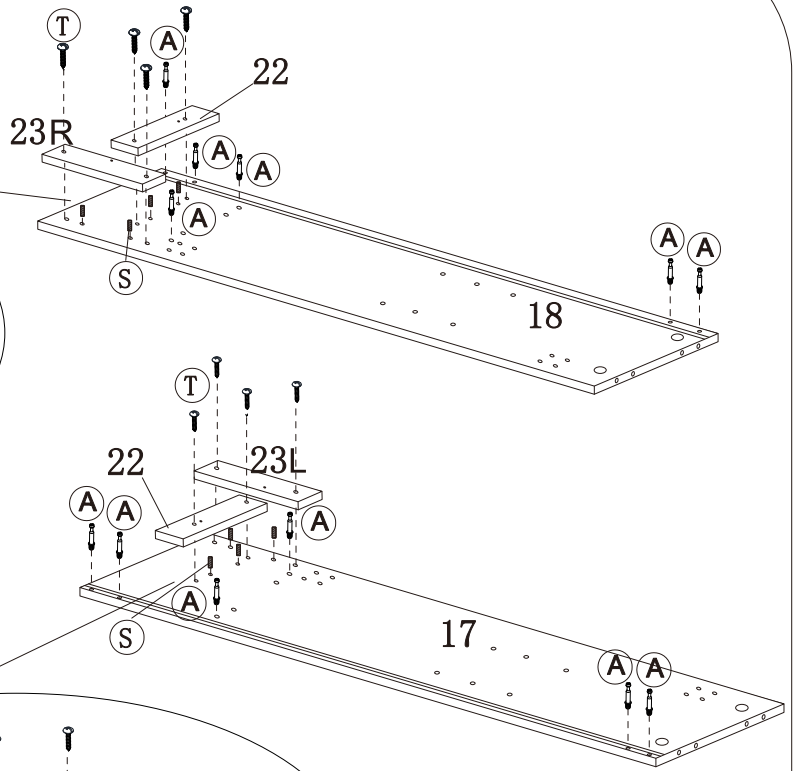
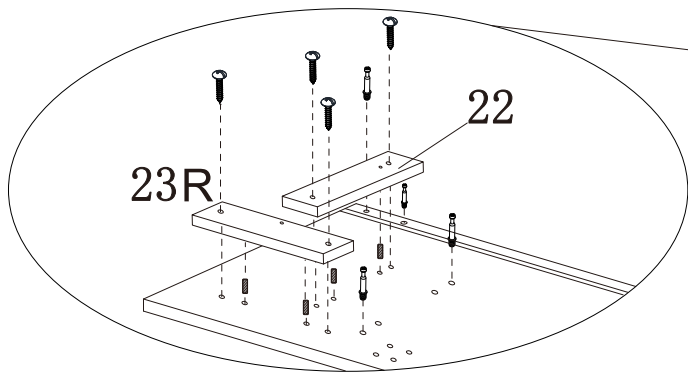

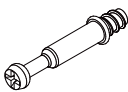
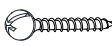
Step 3
Étape 3



- (A)**  x12
- (T)**  x8
Ø4x18mm
- (S)**  x8

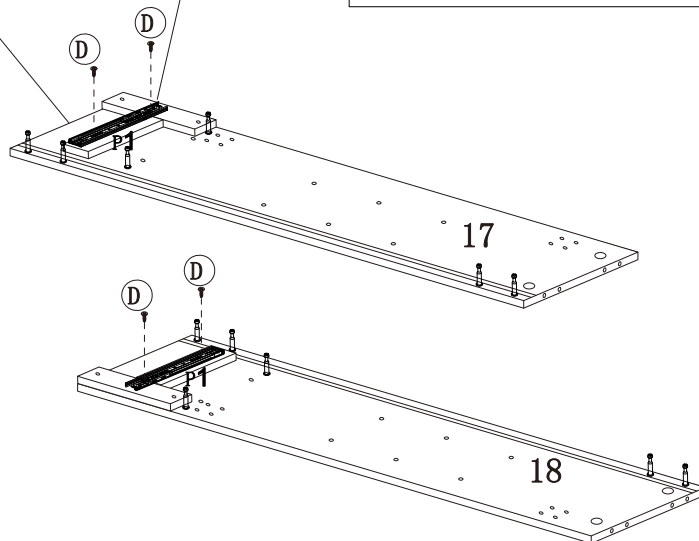
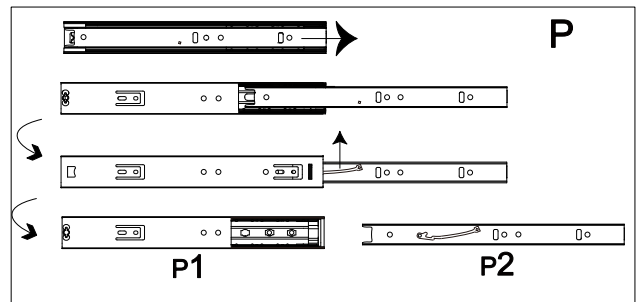
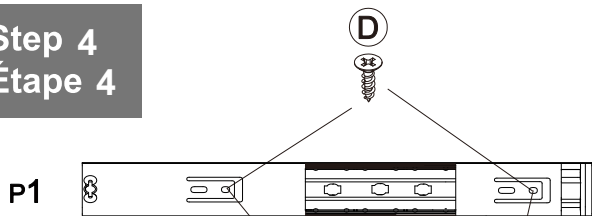

Step 4
Étape 4

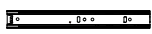

- (D)**  x4
Ø3x12mm
- (P)**  x2

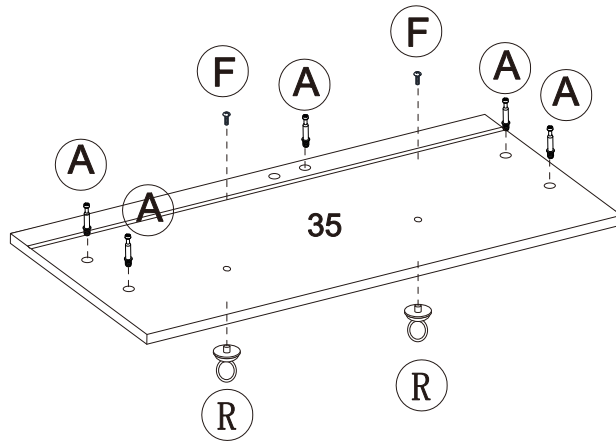
Step 5
Étape 5

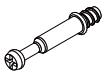

(A)		x5
(F)	 $\varnothing 4 \times 15 \text{mm}$	x2
(R)		x2

Step 6
Étape 6

P₂

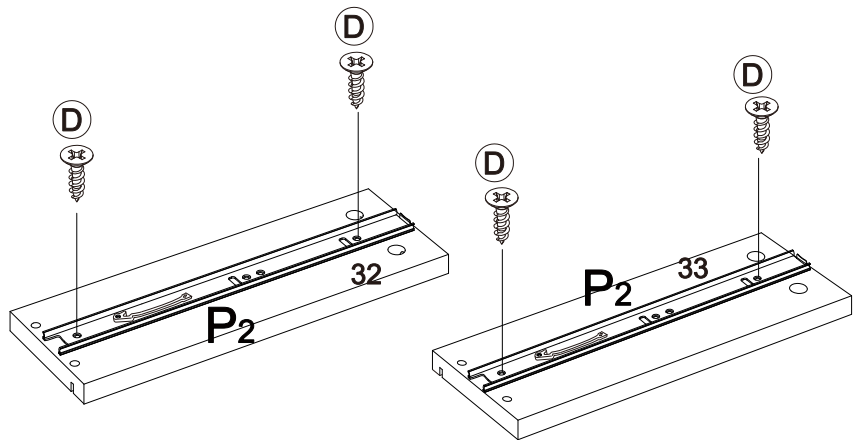
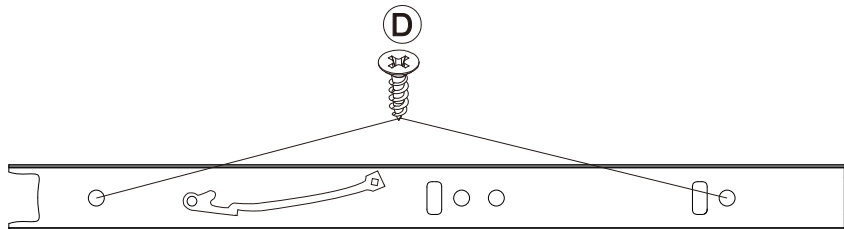

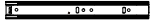

(D)	 $\varnothing 3 \times 12 \text{mm}$	x4
(P)		x2

P₁₂

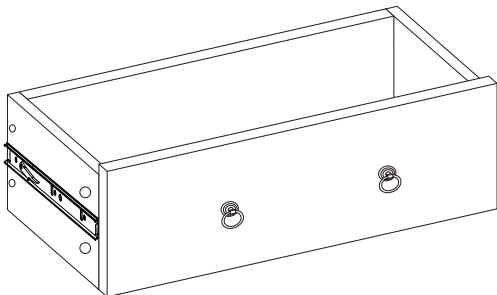
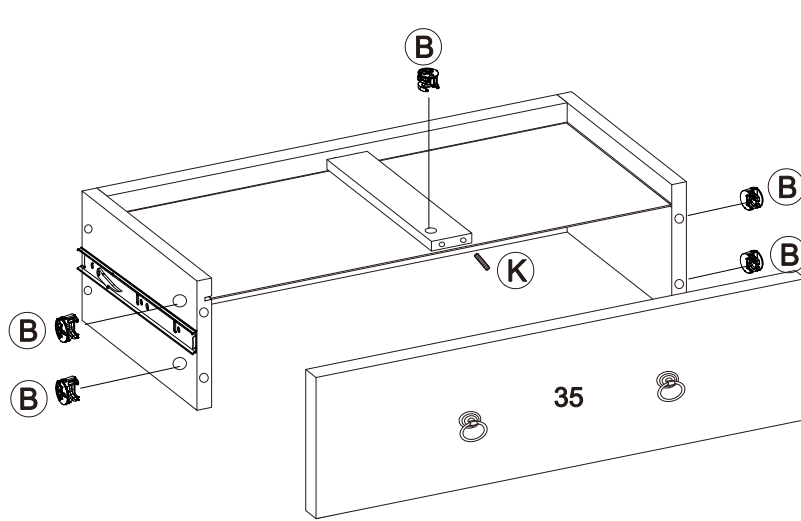
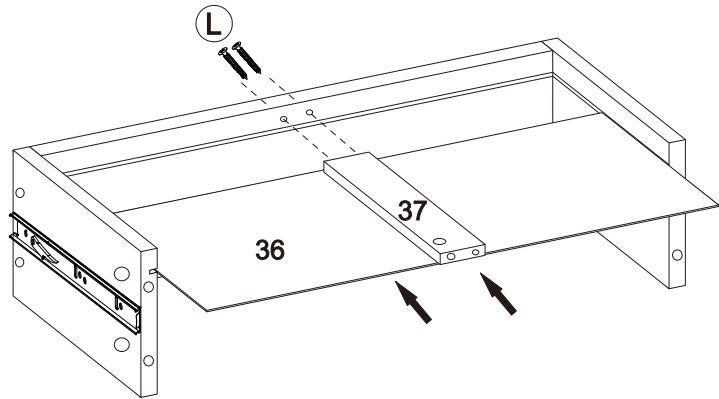
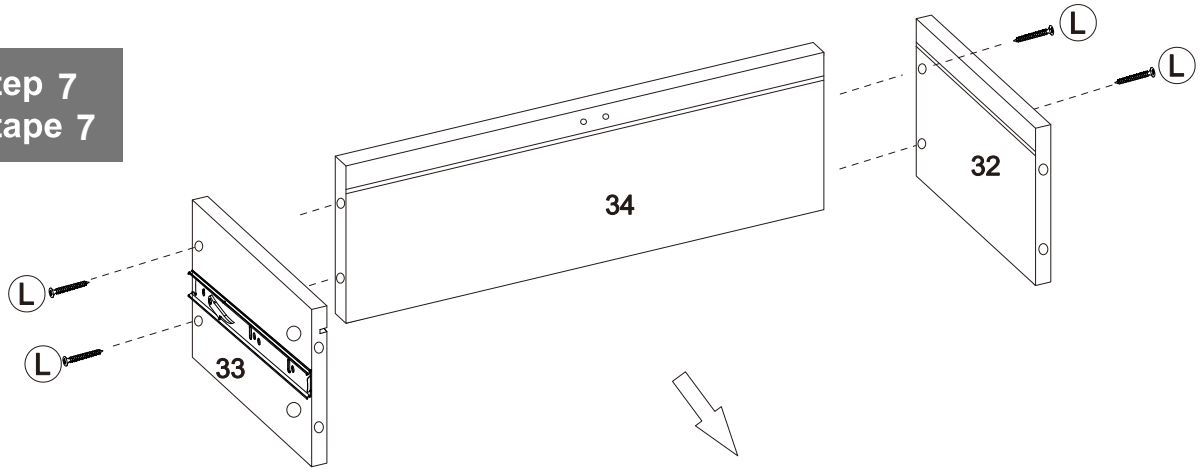

Step 7
Étape 7

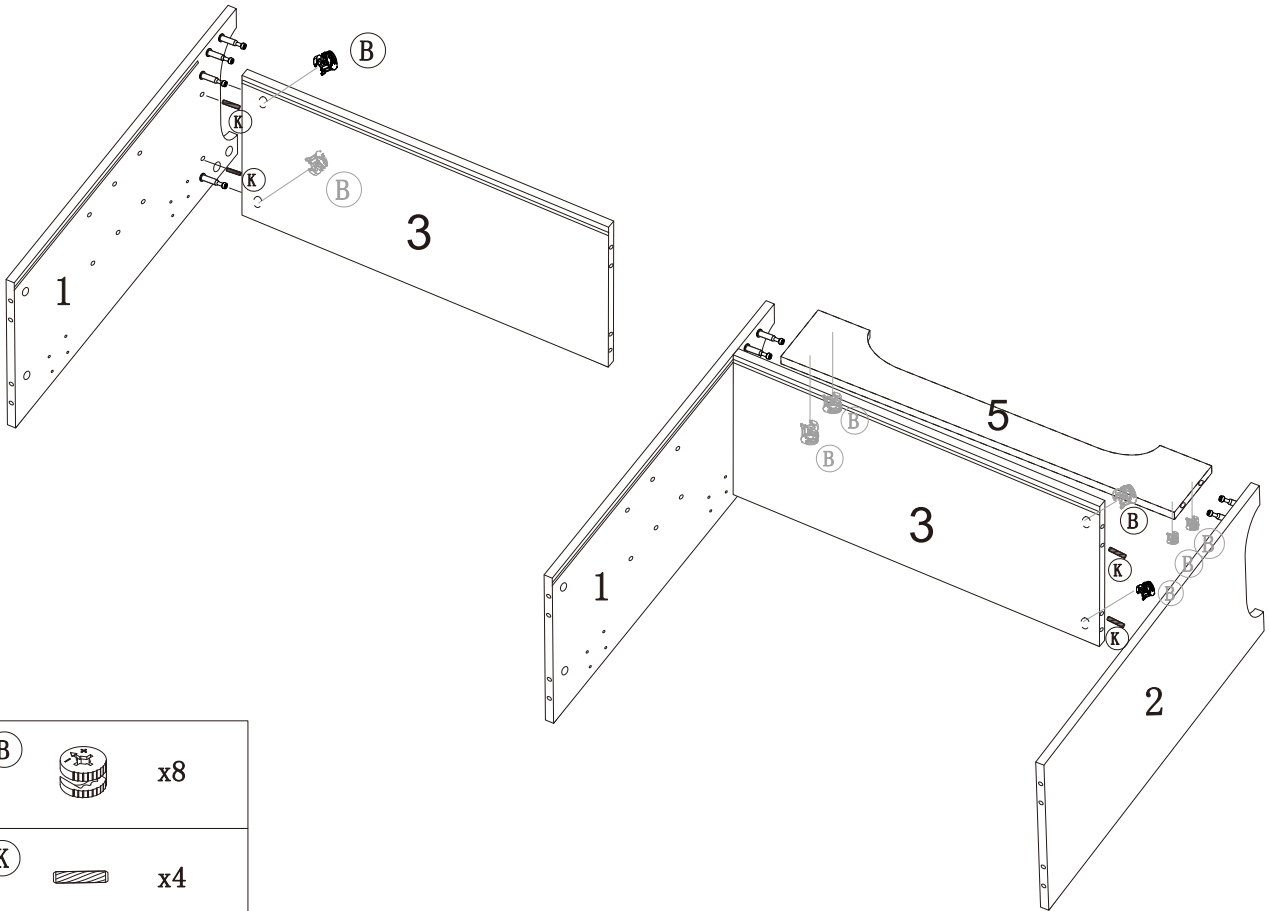

(B)		x5
(K)		x1
(L)	 ∅4x30mm	x6

Step 8
Étape 8



(B)		x8
(K)		x4



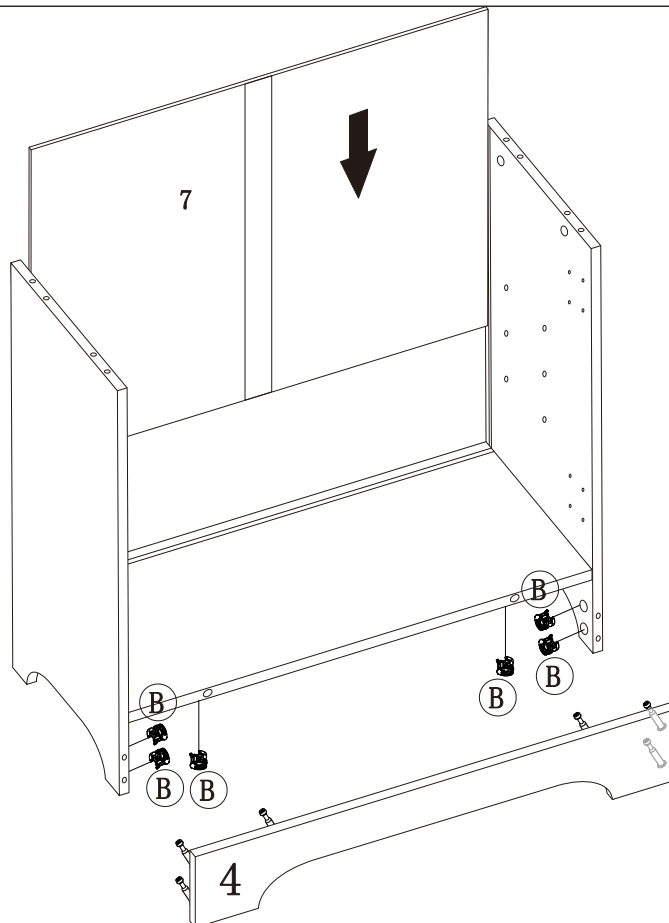

Step 9
Étape 9

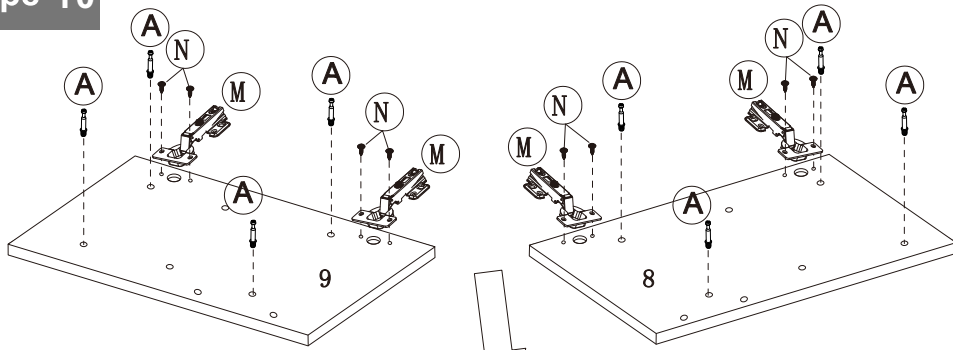

(B)		x6
-----	---	----

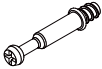
Step 10
Étape 10





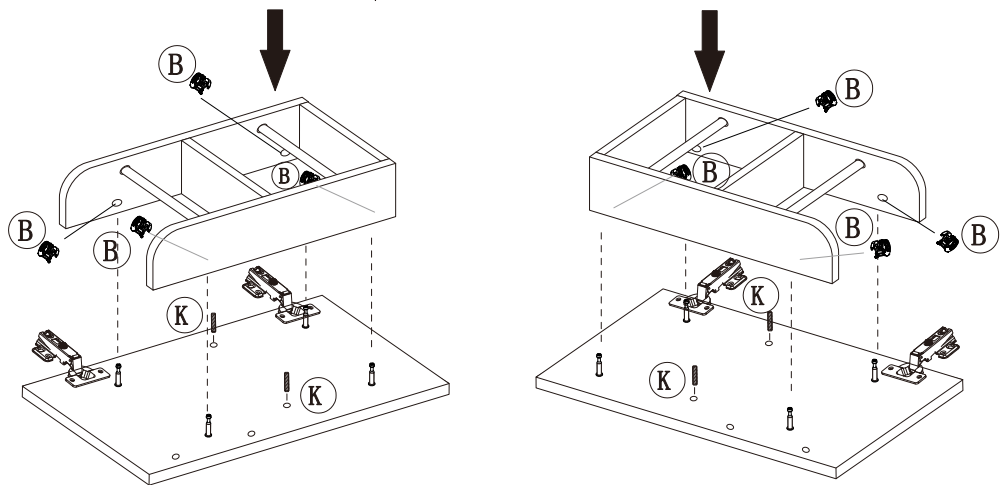

A		x8
B		x8
K		x4
M		x4
N		x8 Ø4x14mm

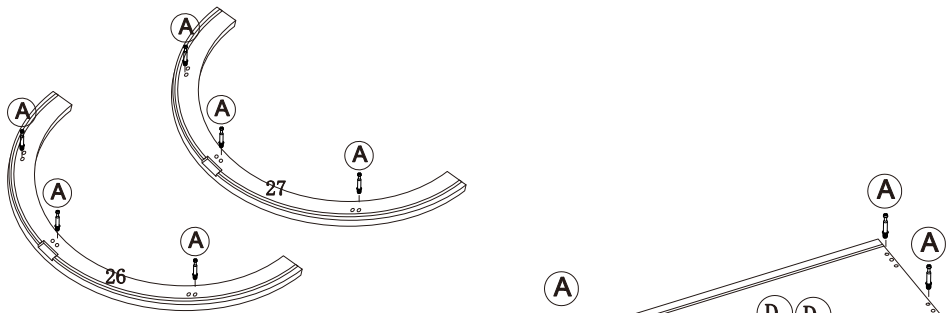

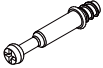
Step 11
Étape 11



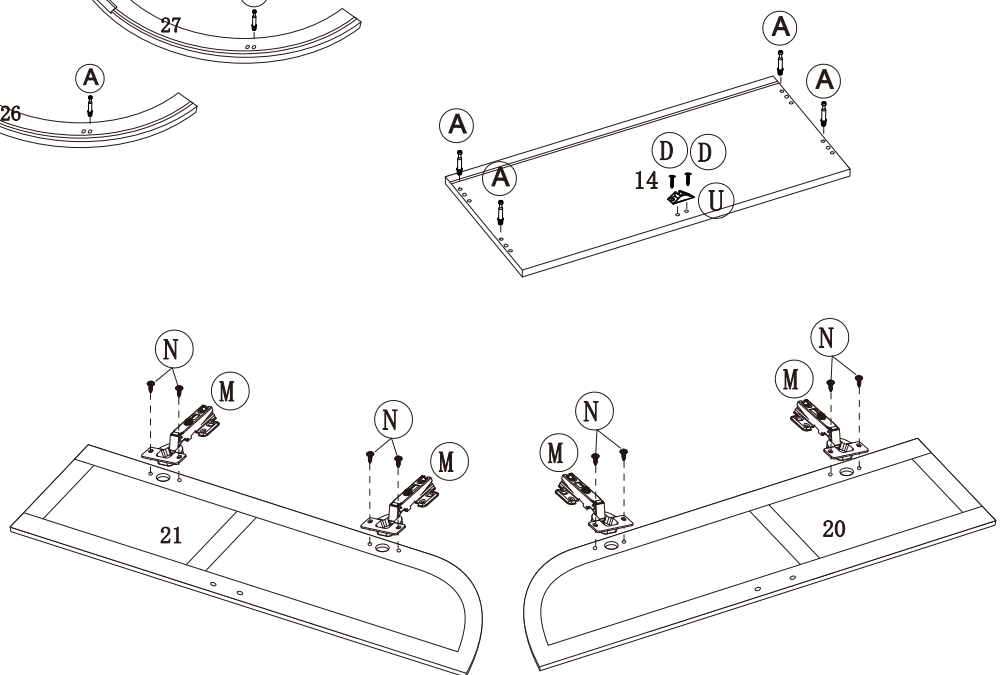

A		x10
D		x2 Ø3x12mm
M		x4
N		x8 Ø4x14mm
U		x1

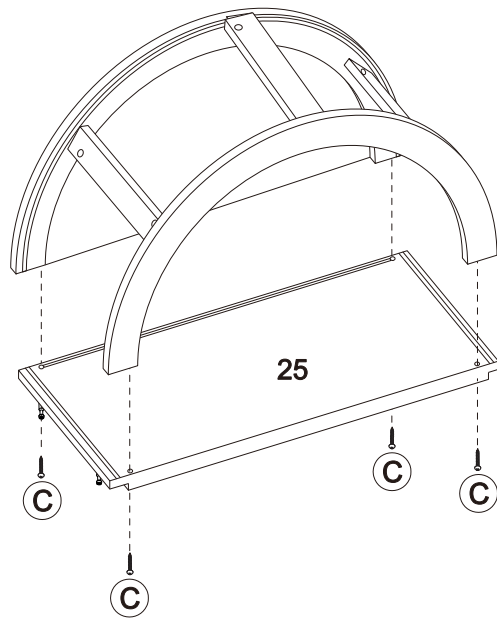
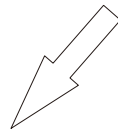
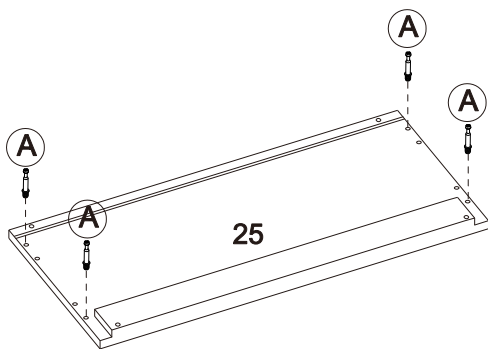
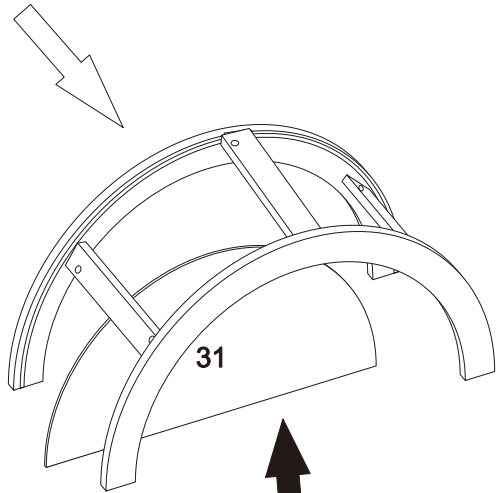
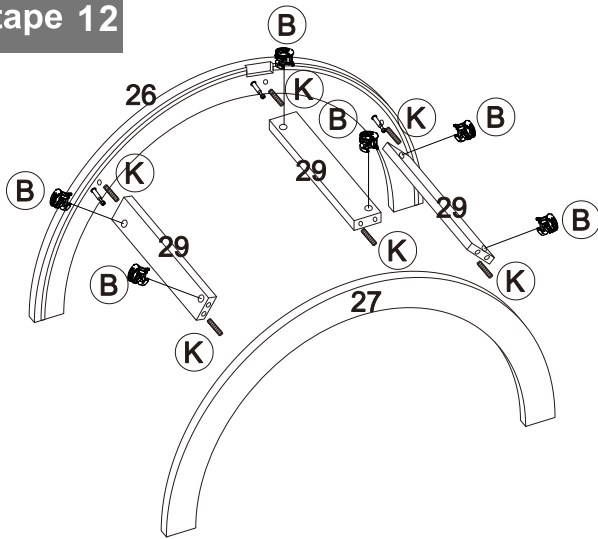

Step 12
Étape 12

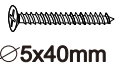

(A)		x4
(C)	 Ø5x40mm	x4
(B)		x6
(K)		x6

Step 13
Étape 13

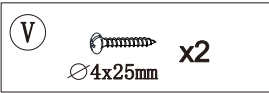
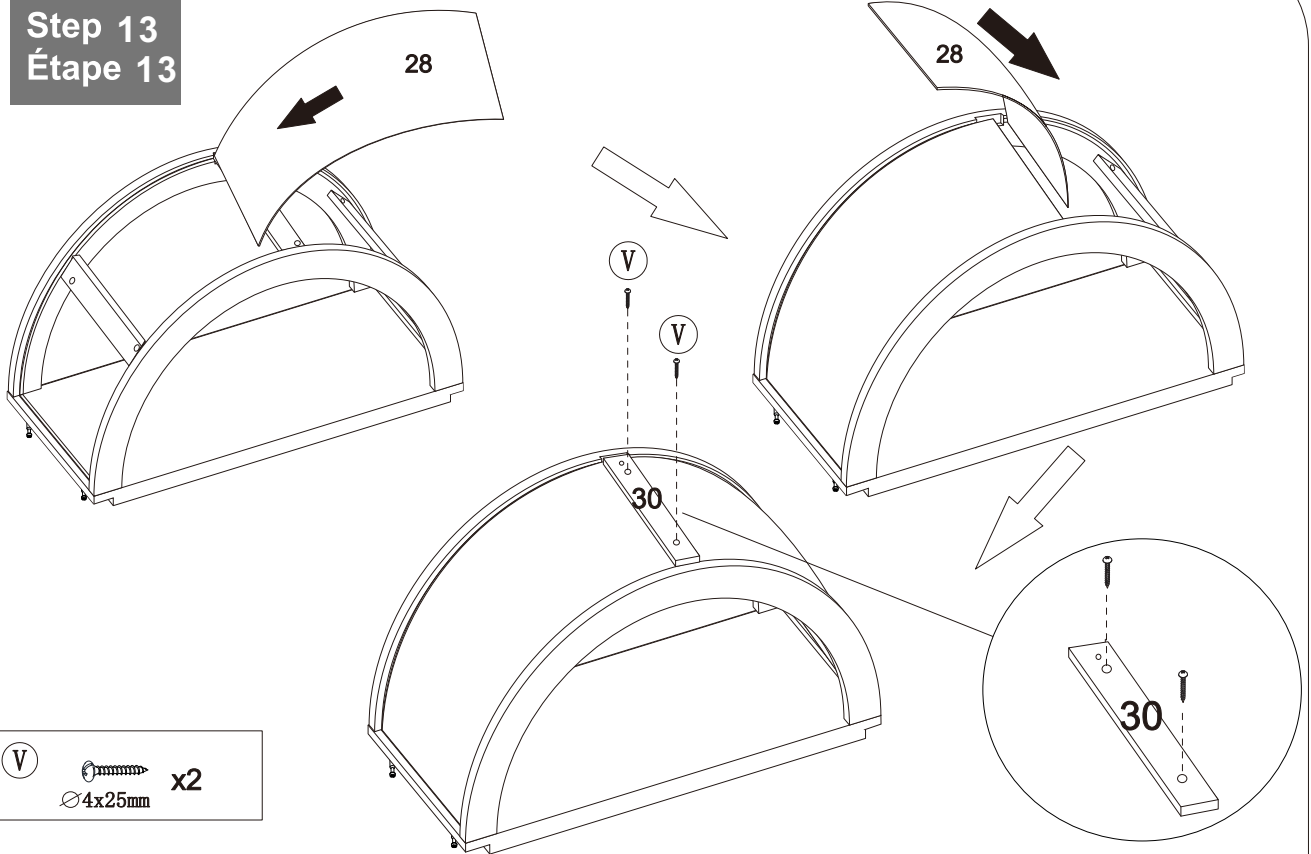

Step 14
Étape 14

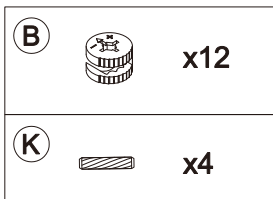
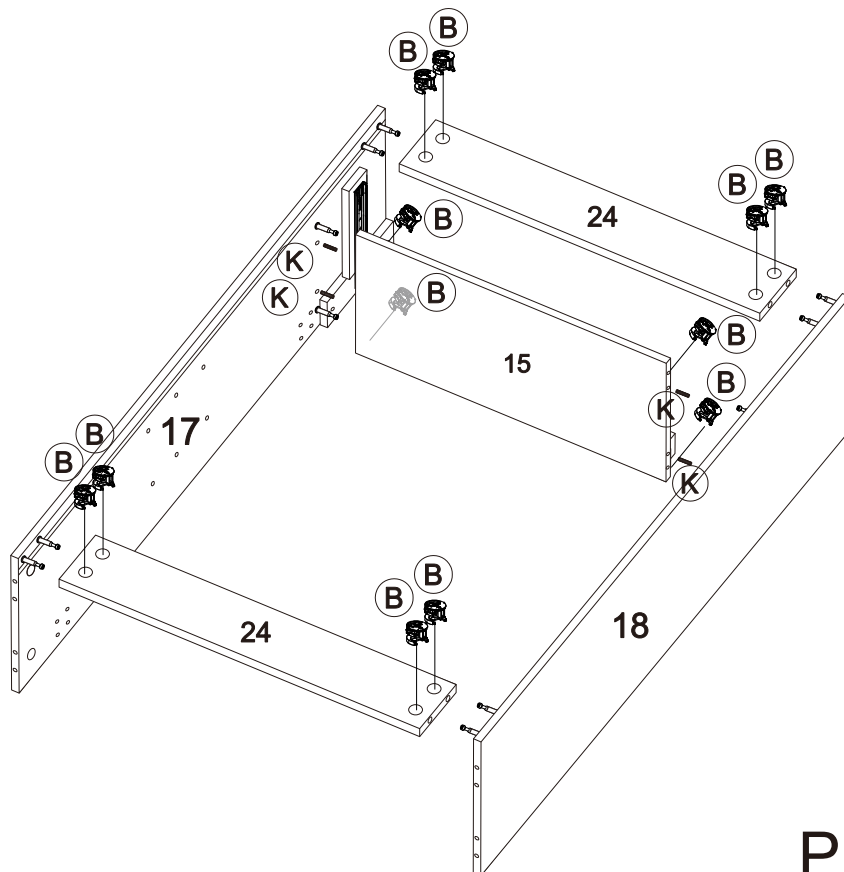

Step 15
Étape 15

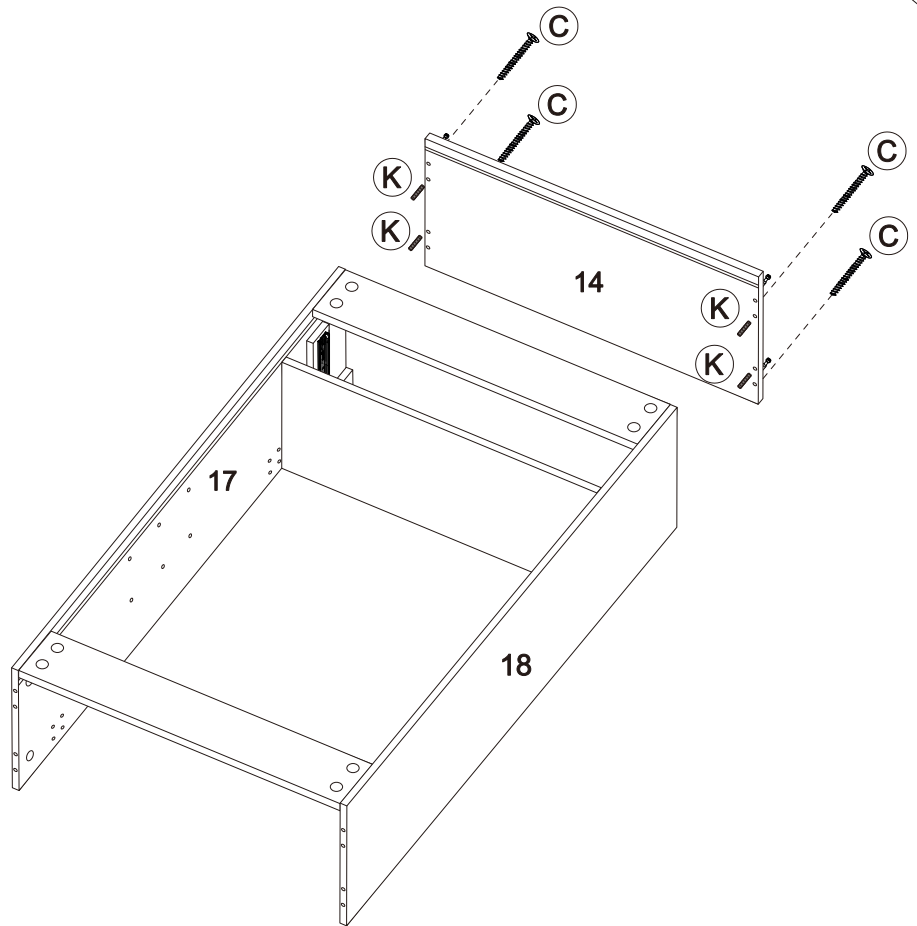

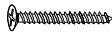
(C)  x4
Ø5x40mm

(K)  x4

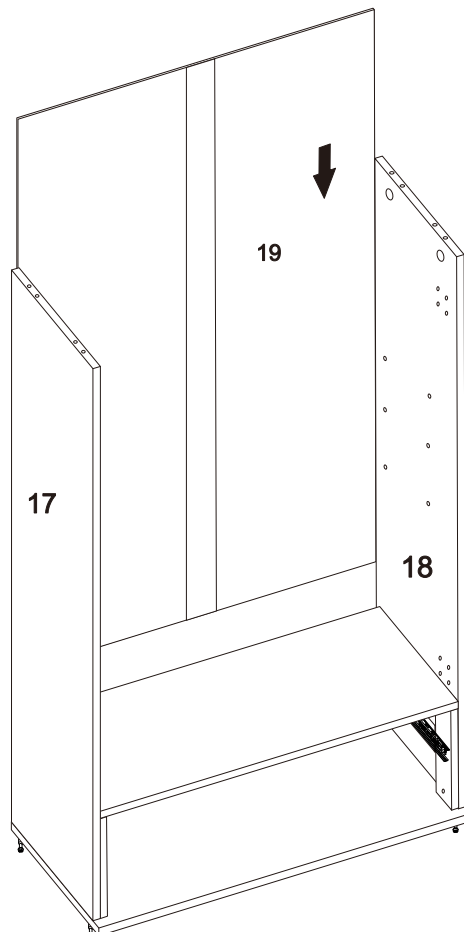

Step 16
Étape 16



P18

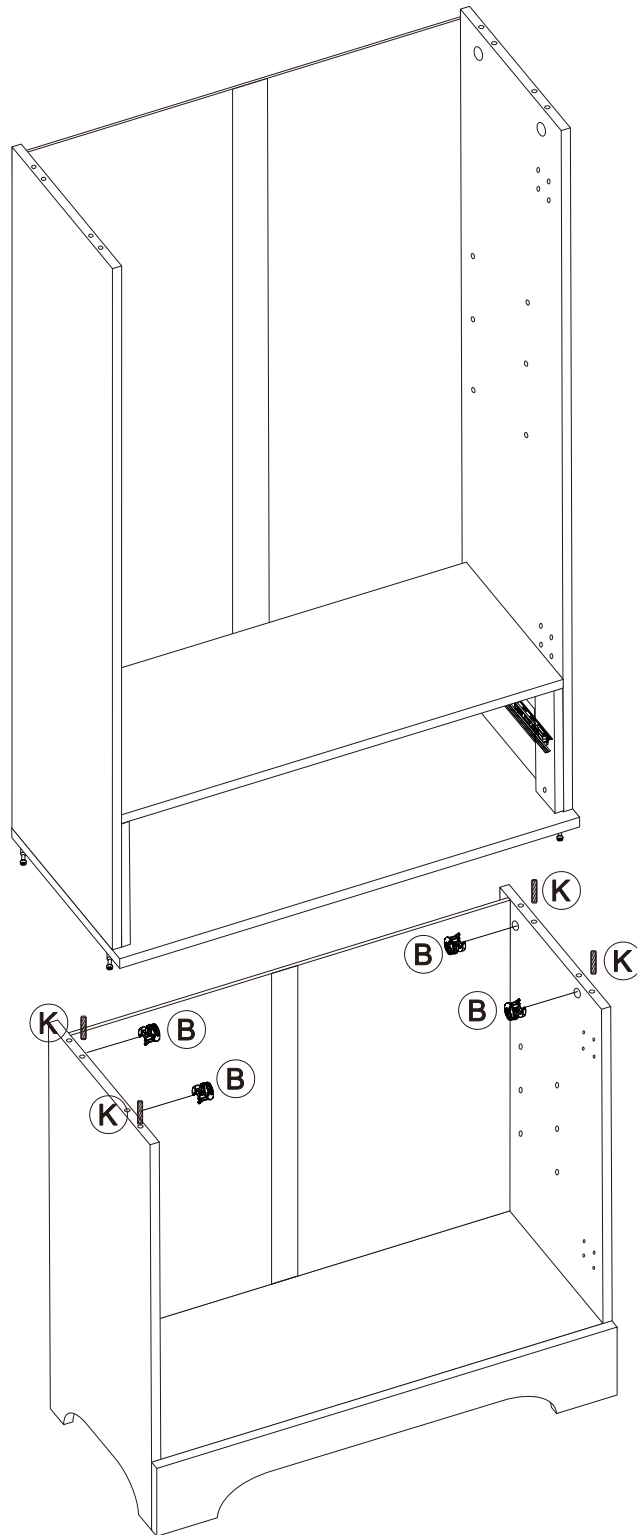

Step 17
Étape 17

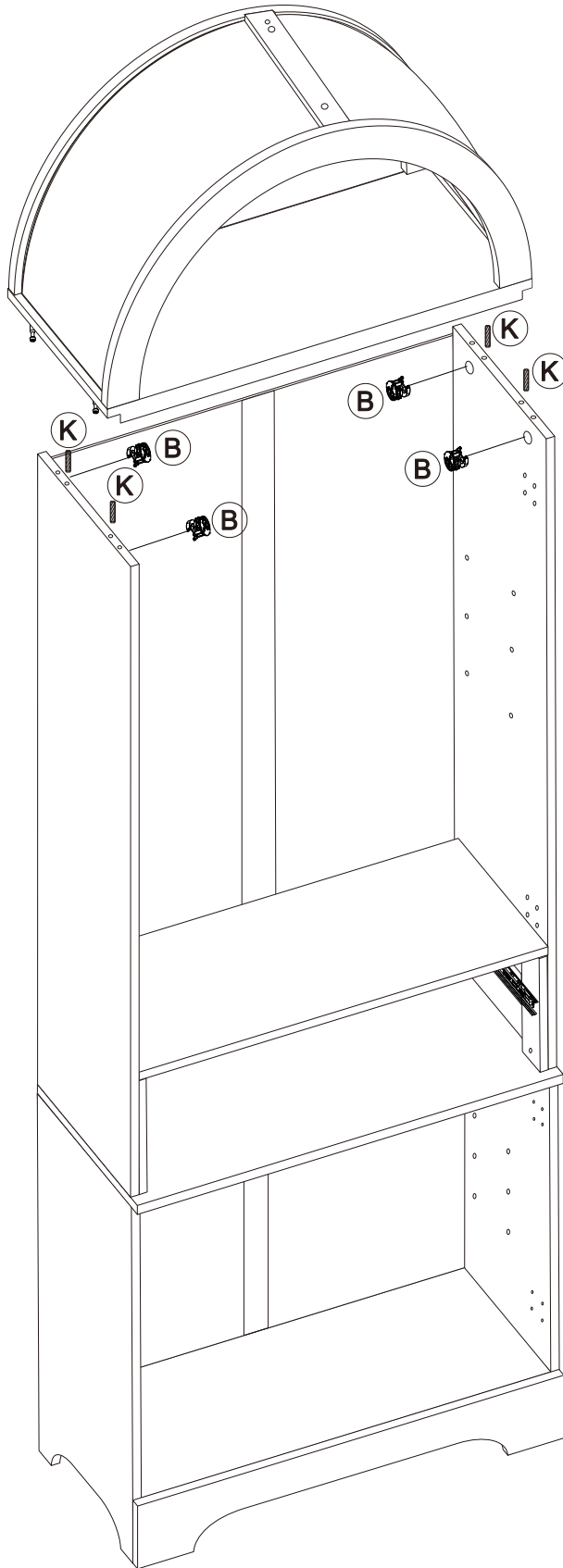

B		x4
K		x4

Step 18
Étape 18



B		x4
K		x4

Step 19
Étape 19

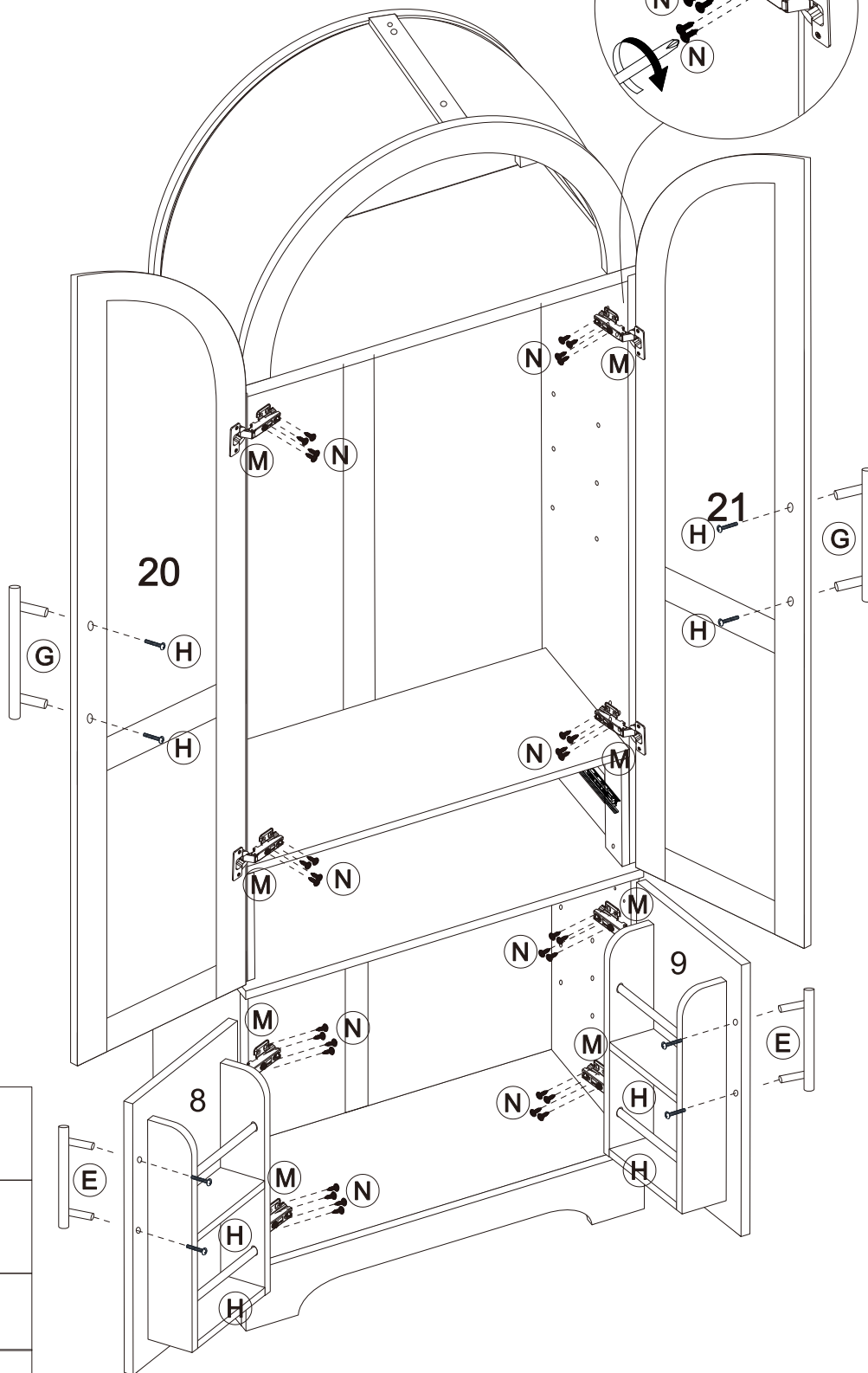
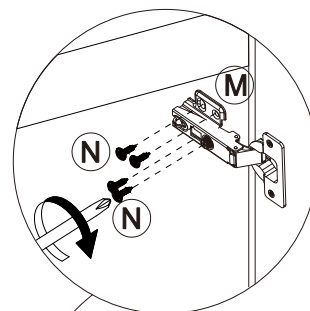
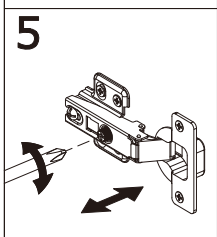
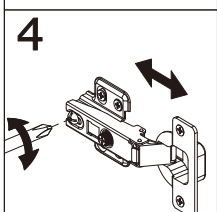
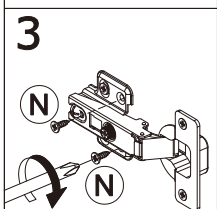
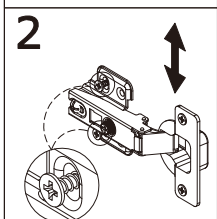
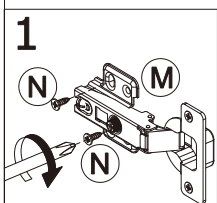

(E)  x2

(G)  x2

(H)  $\varnothing 4 \times 25 \text{mm}$ x8

(N)  $\varnothing 4 \times 14 \text{mm}$ x32

P21

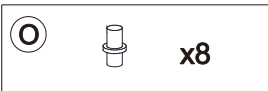
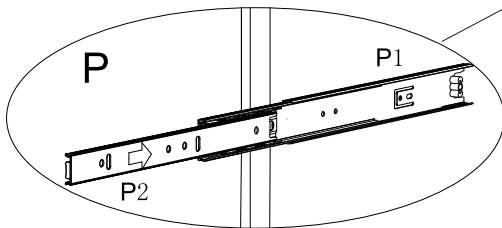
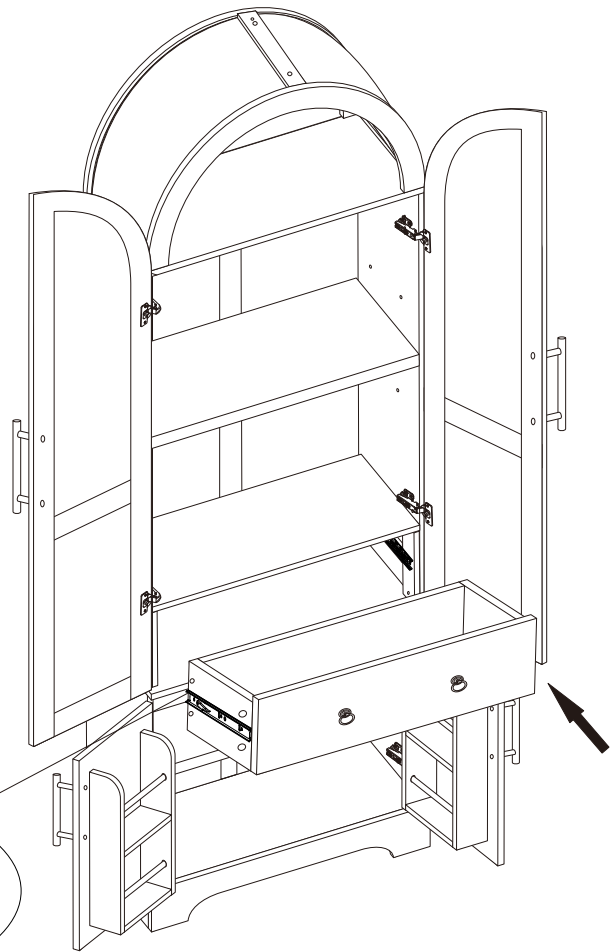
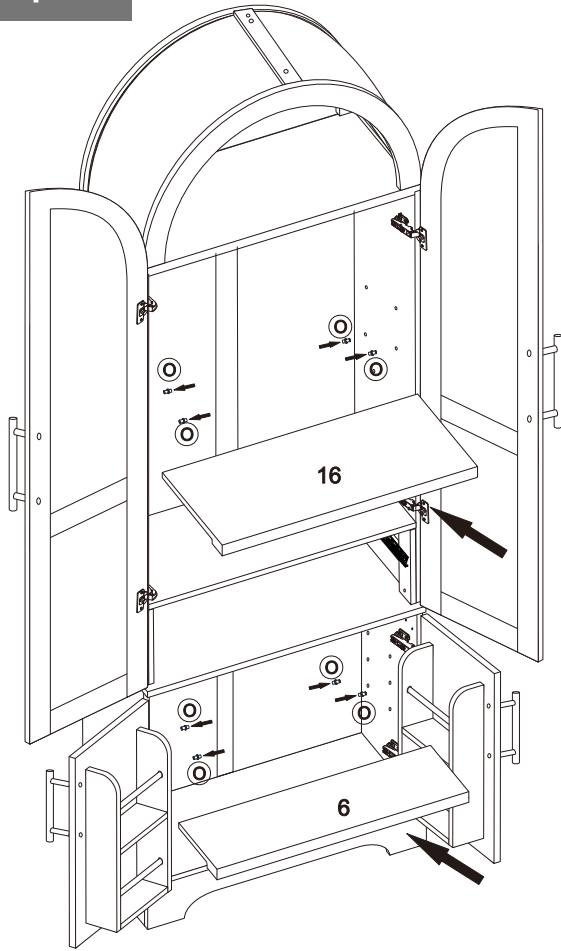

Step 20
Étape 20

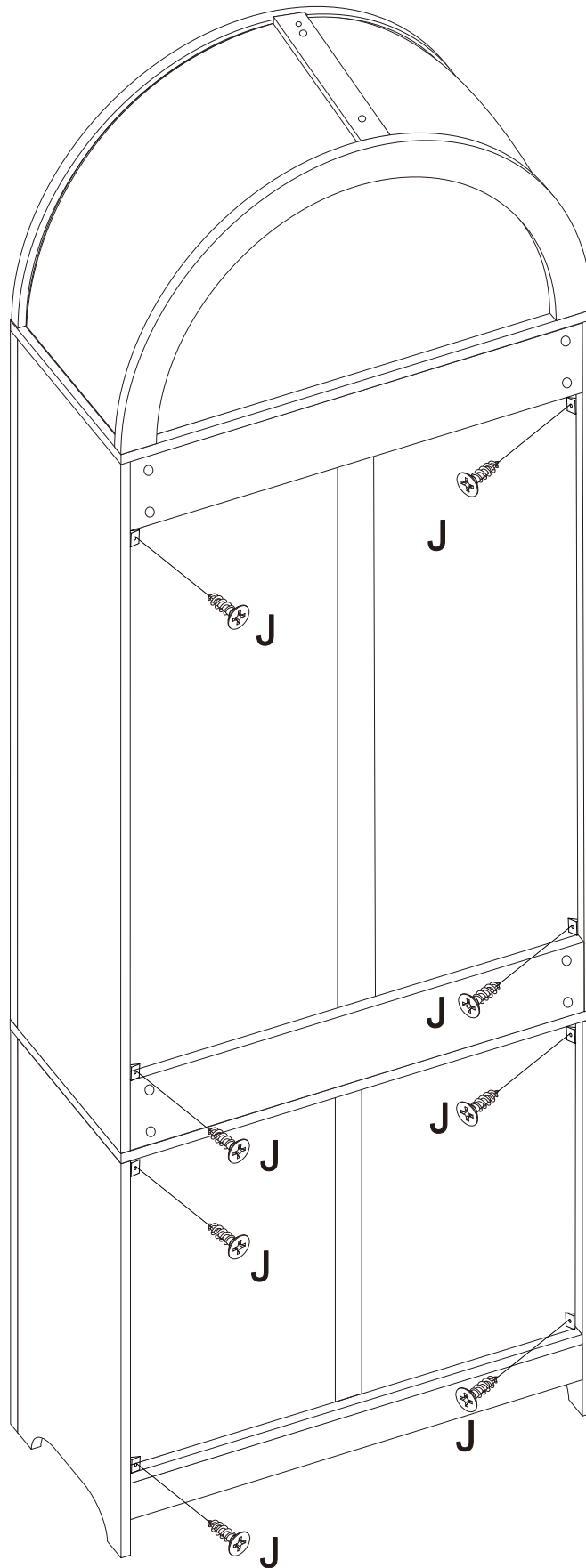

P22

Step 21
Étape 21



I	 x8
J	 $\varnothing 3 \times 16 \text{mm}$ x8

Step 22
Étape 22

