

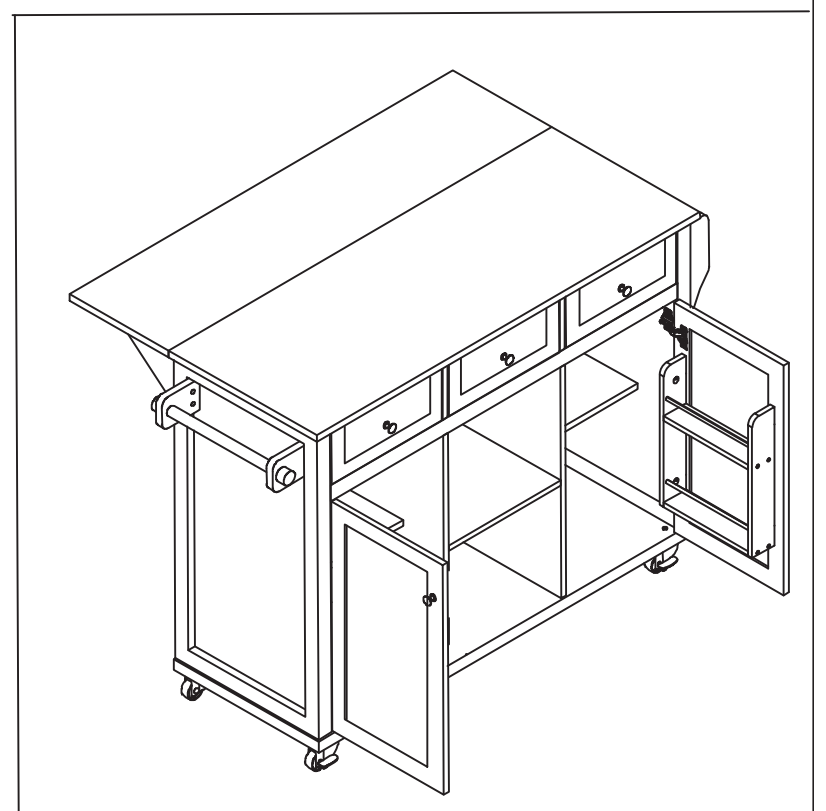

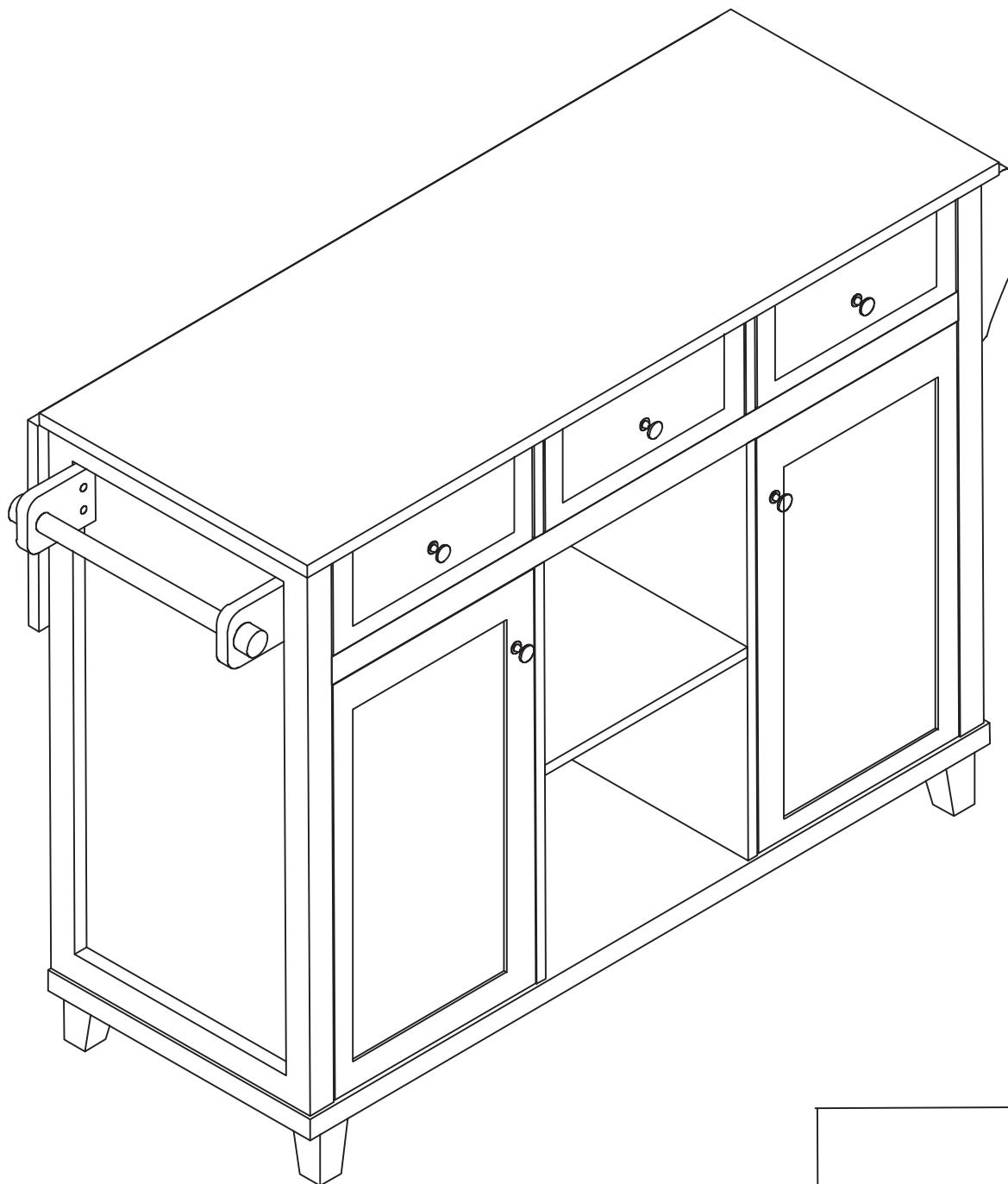

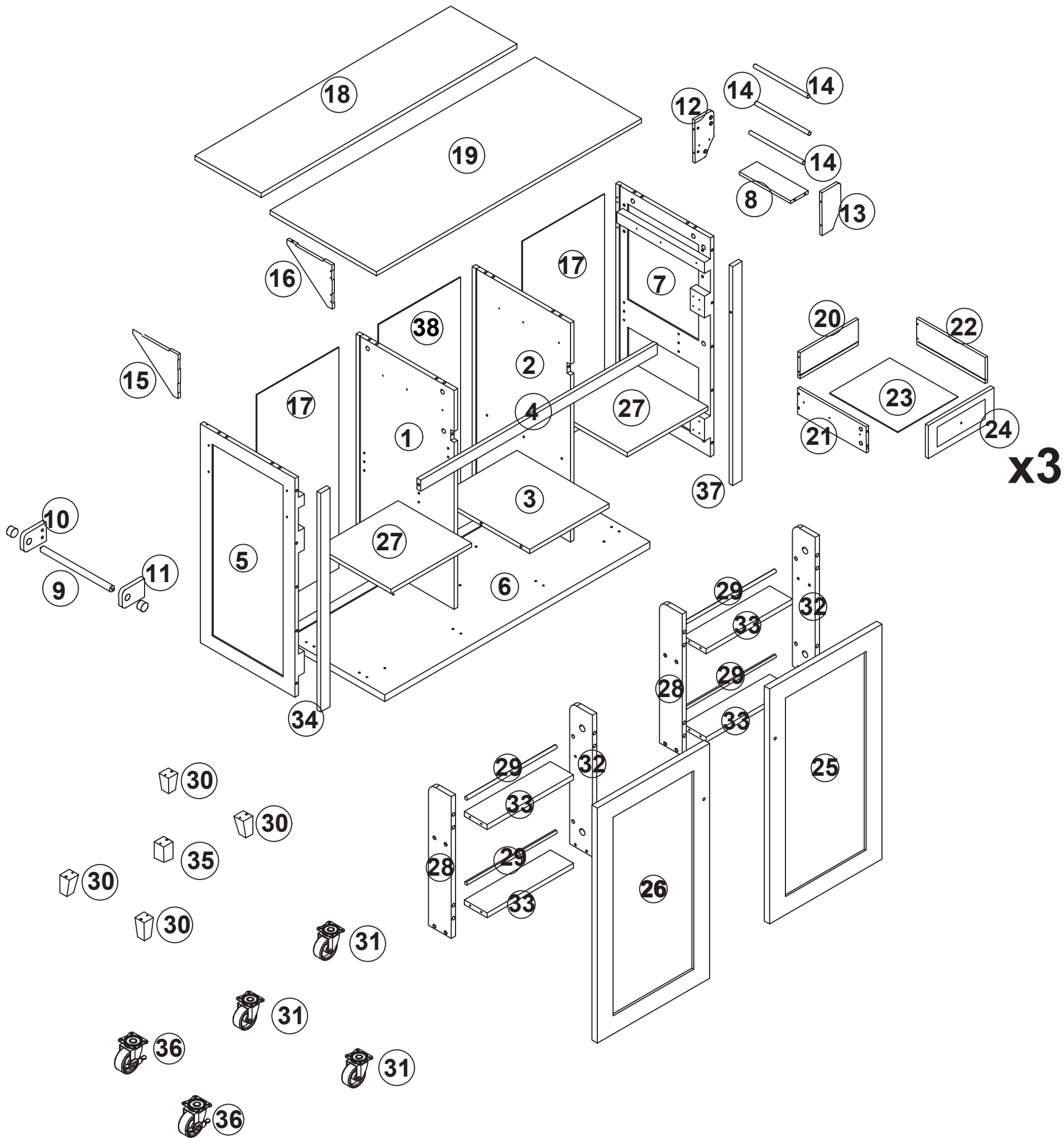

Assembly Instruction /Montageanleitung

N853P266189 + N853P266190

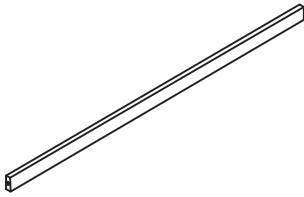
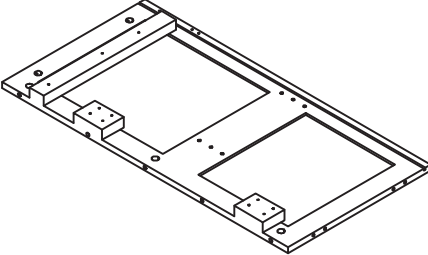
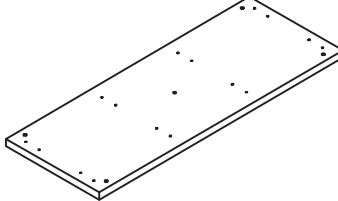
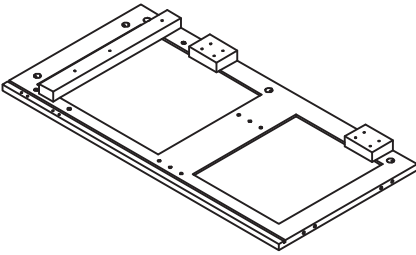
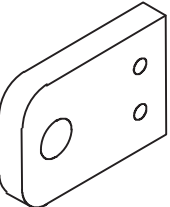
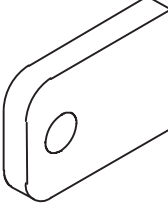

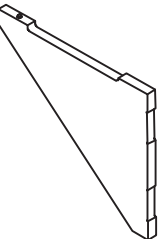
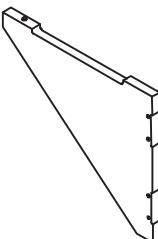

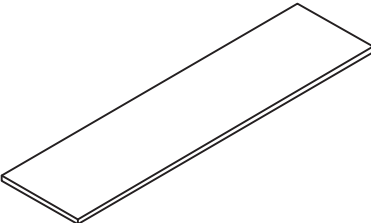
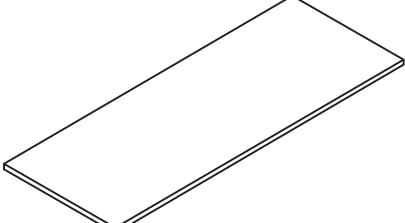
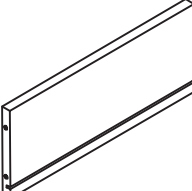
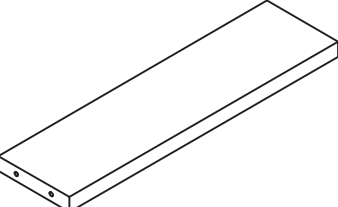

N853P266189

| | | | |
|---|---|---|---|
|  ④ x 1 |  ⑤ x 1 |  ⑥ x 1 |  ⑦ x 1 |
|  ⑩ x 1 |  ⑪ x 1 |  ⑫ x 1 |  ⑬ x 1 |
|  ⑮ x 1 |  ⑯ x 1 |  ⑰ x 2 |  ⑱ x 1 |
|  ⑲ x 1 |  ⑳ x 3 |  ⑳ x 4 |  ㉔ x 1 |

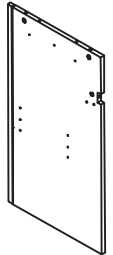
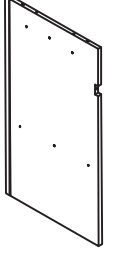
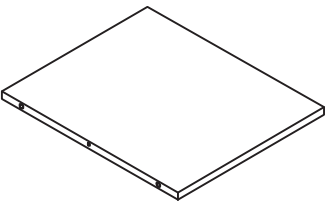
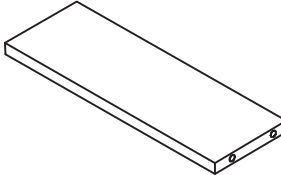
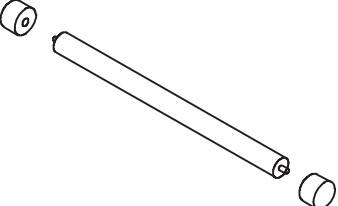
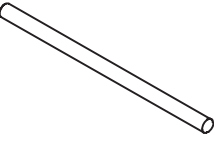
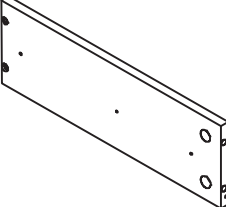
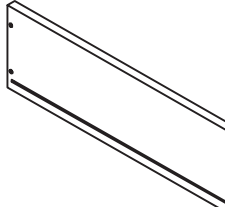
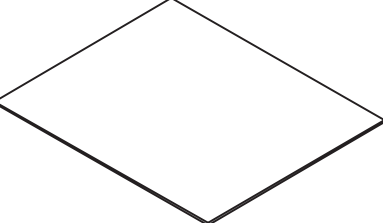
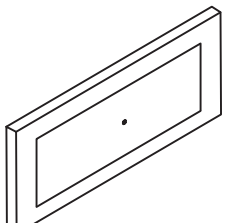
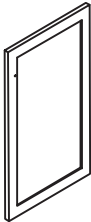
N853P266190

| | | | |
|---|---|---|---|
|  ① x 1 |  ② x 1 |  ③ x 1 |  ⑧ x 1 |
|  ⑨ x 1 |  ⑭ x 3 |  ⑰ x 3 |  ⑱ x 3 |
|  ⑳ x 3 |  ㉑ x 3 |  ㉒ x 1 |  ㉓ x 1 |

step 1 / étape 1

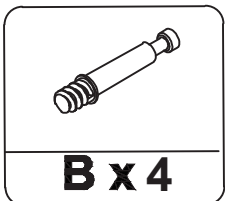
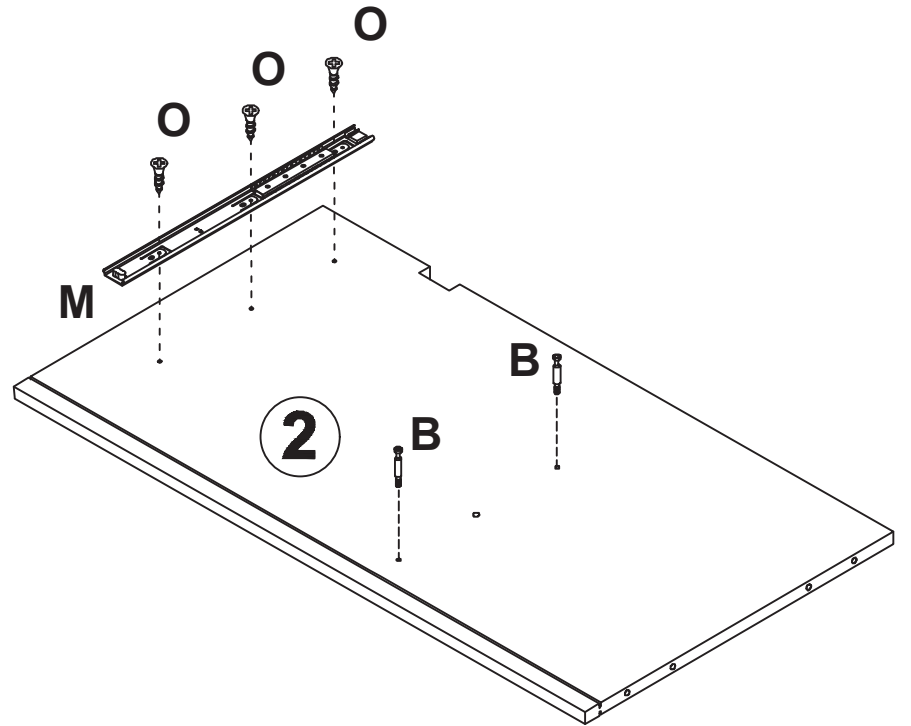
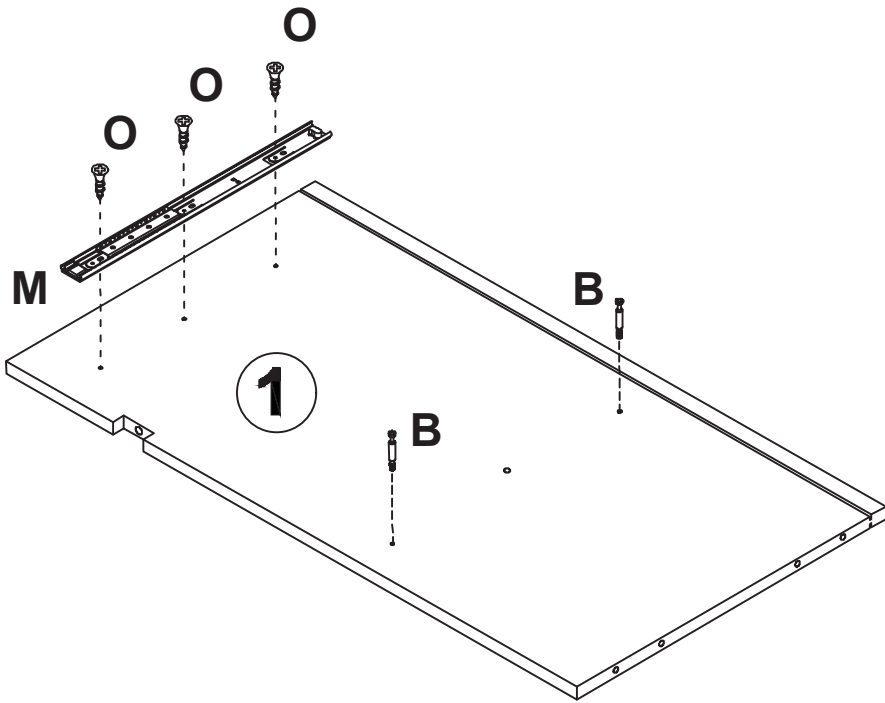
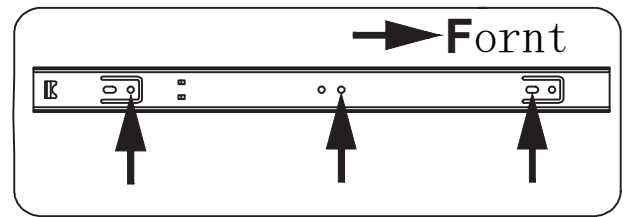

B x 4

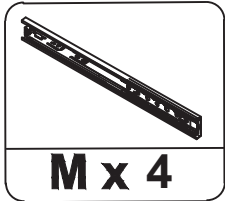

M x 4



**Φ3x12mm
O x 12**

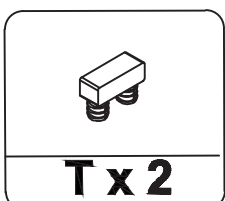

T x 2

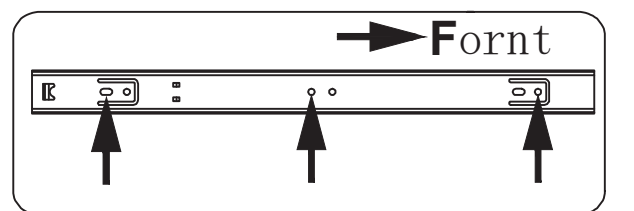
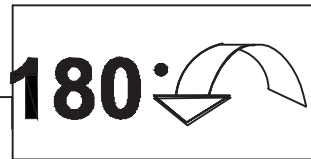

x 2

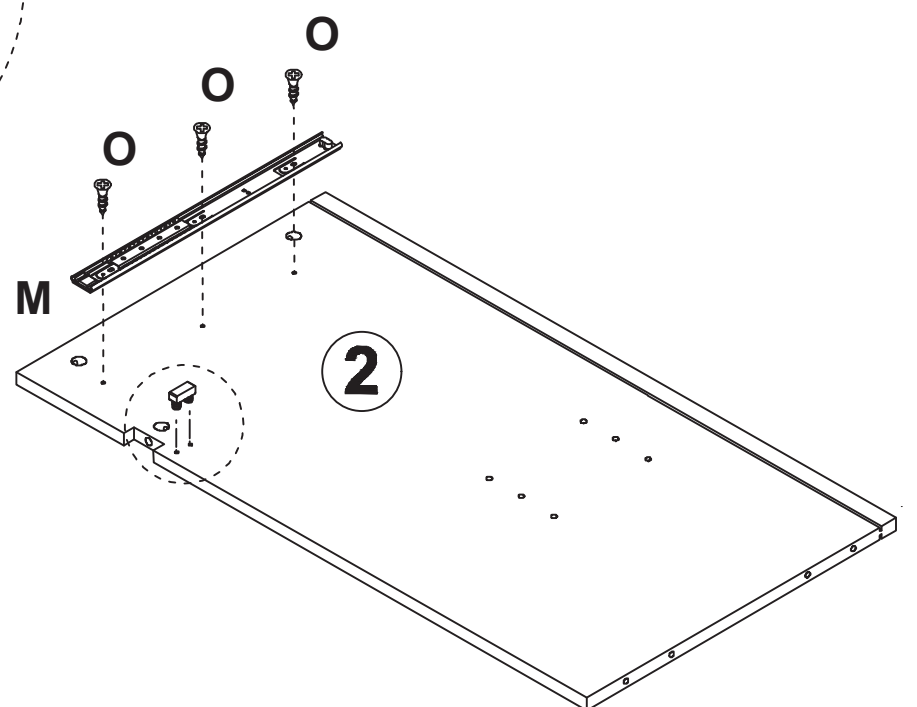
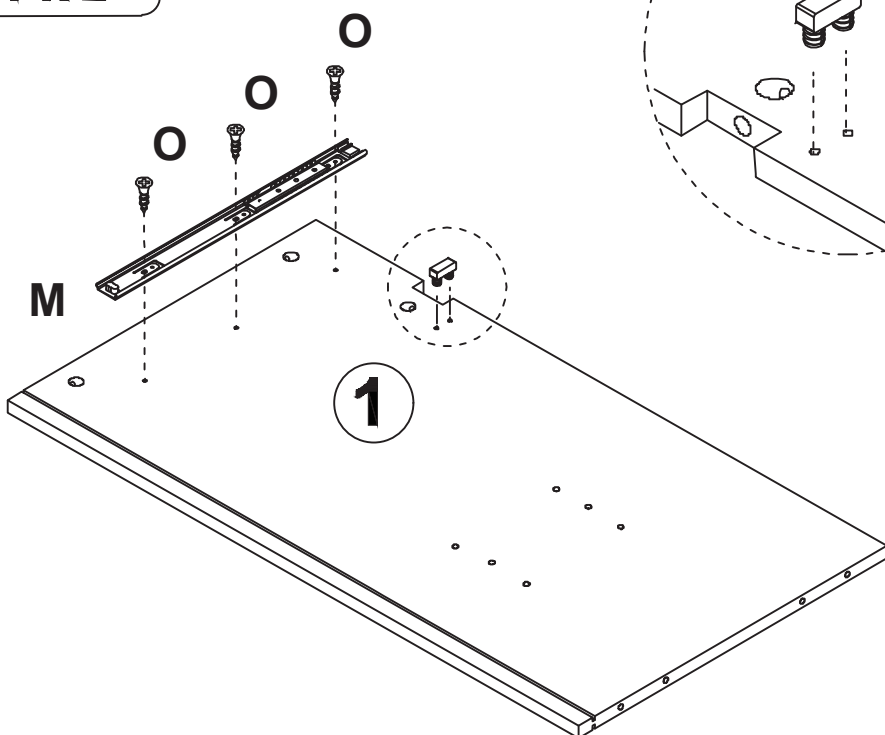
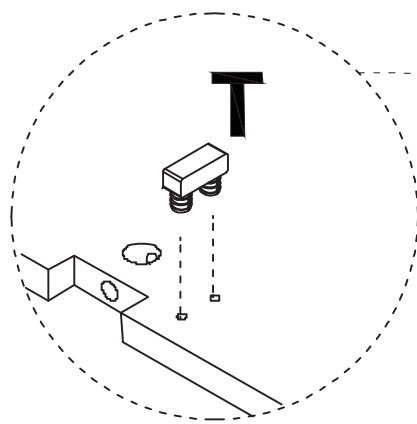

step 2 / étape 2

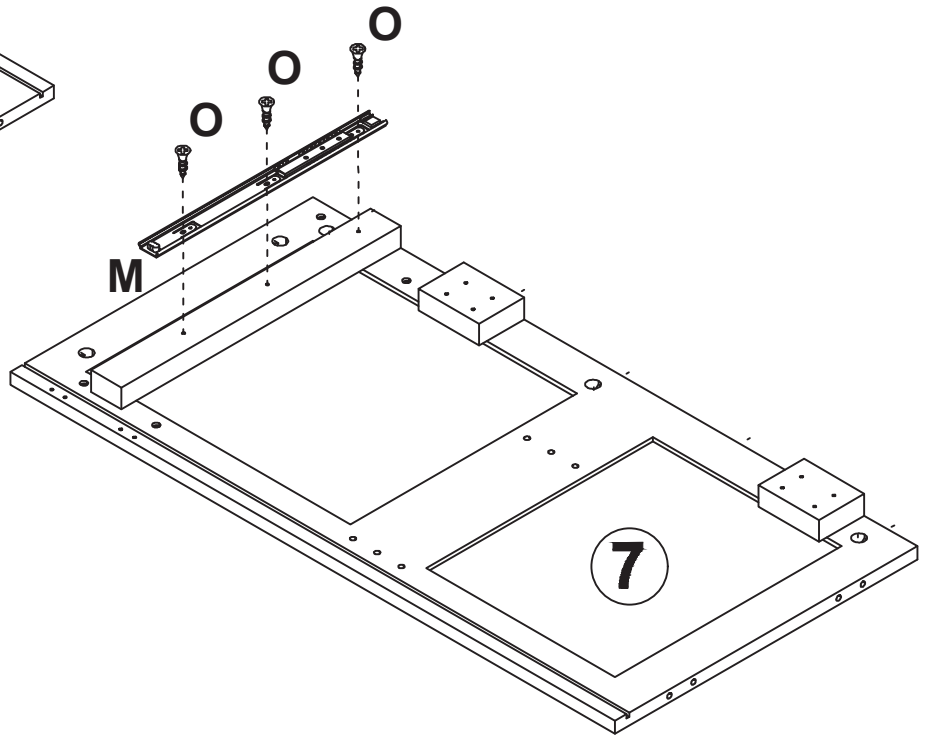
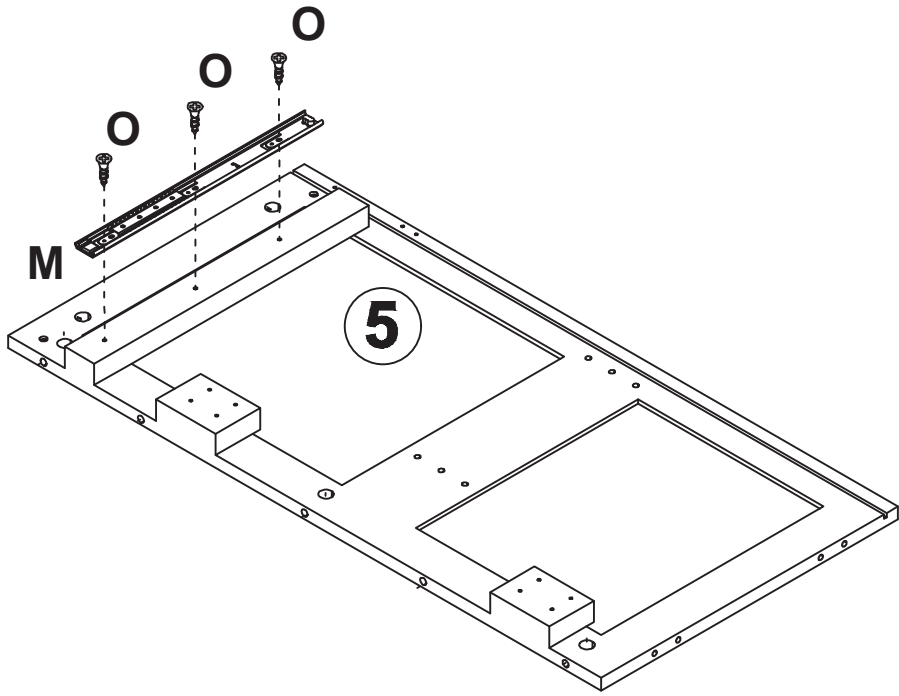
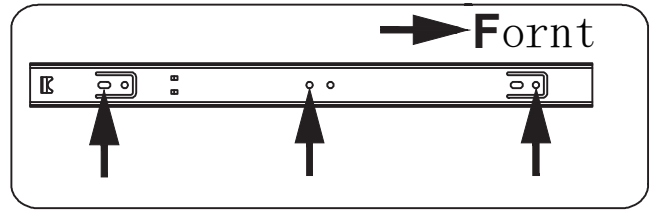

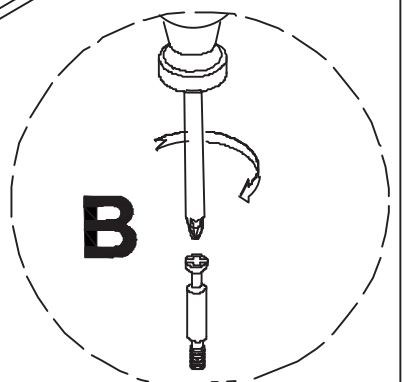
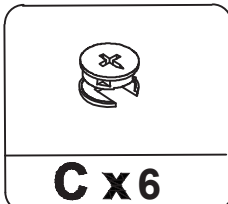
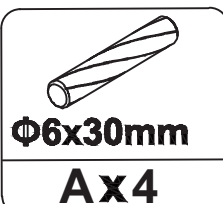
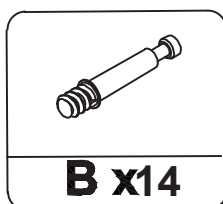
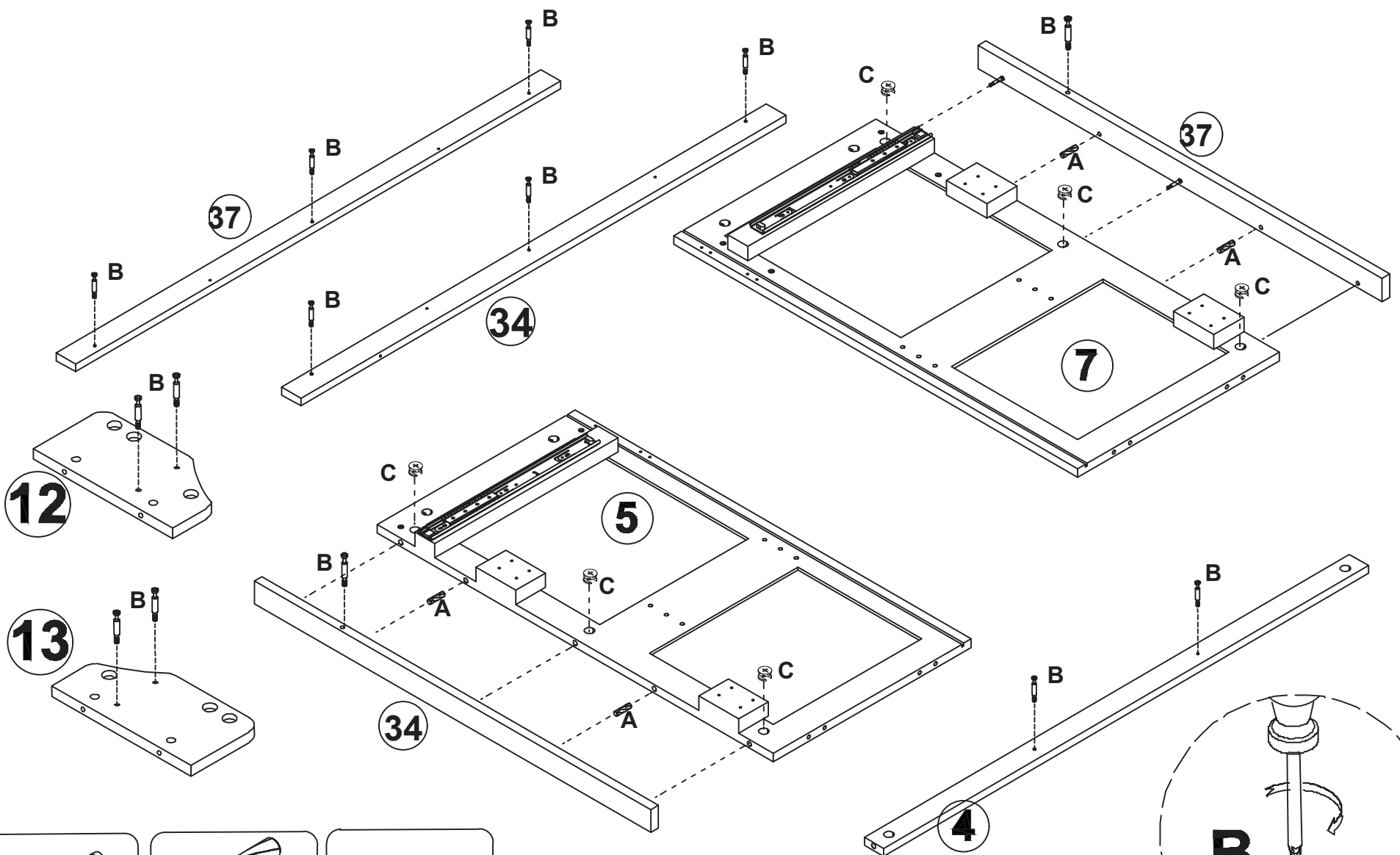

step 3 / étape 3



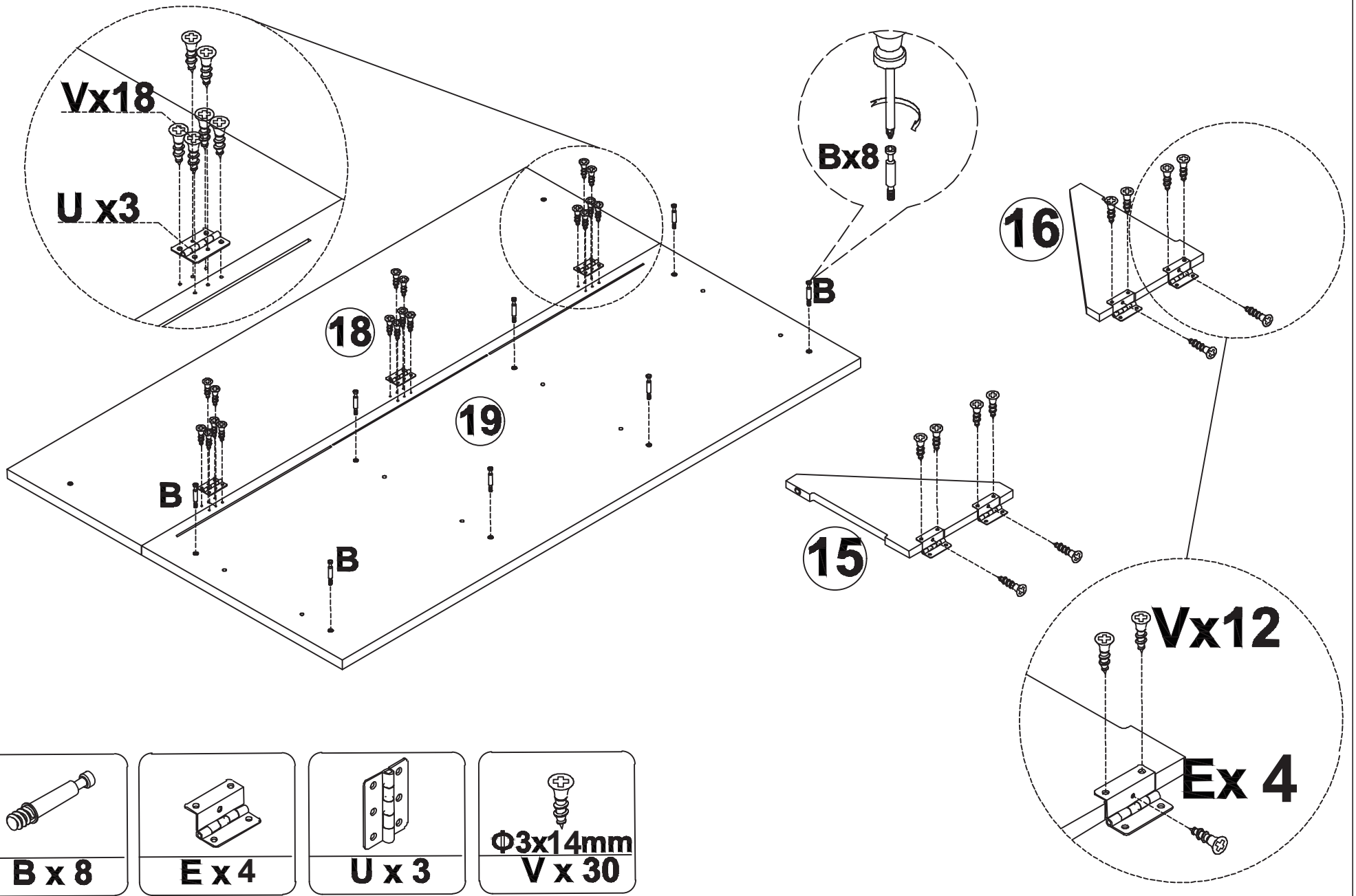

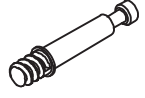
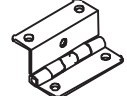
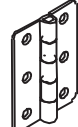
step 4 / étape 4

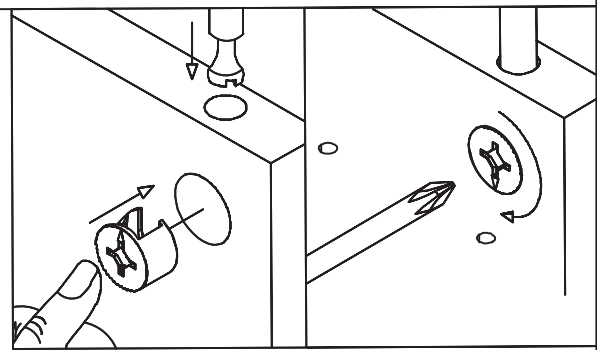
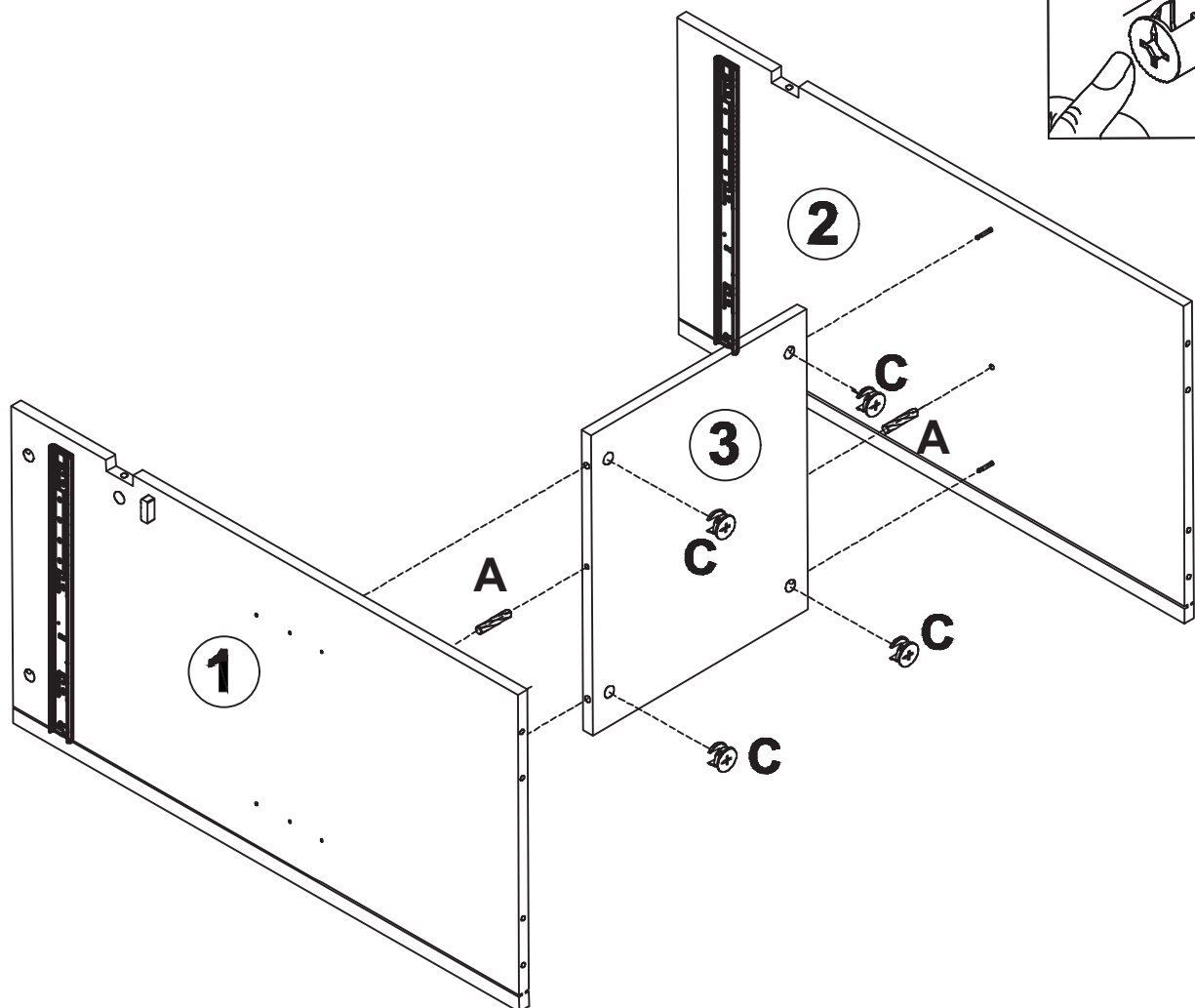

| | | | |
|---|---|---|---|
|  |  |  |  |
| B x 8 | E x 4 | U x 3 | Φ3x14mm V x 30 |

step 5 / étape 5



| | |
|---|---|
|  |  |
| Φ6x30mm A x 2 | C x 4 |

step 6 / étape 6

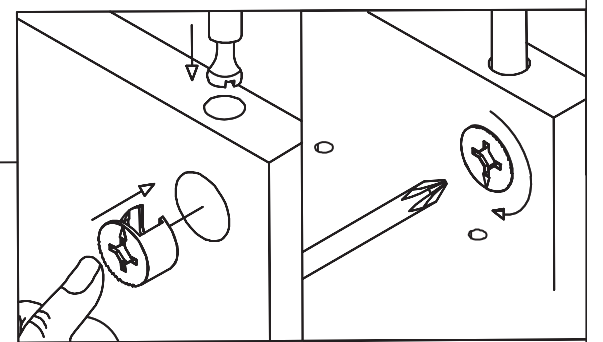
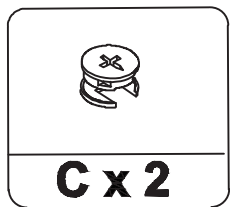
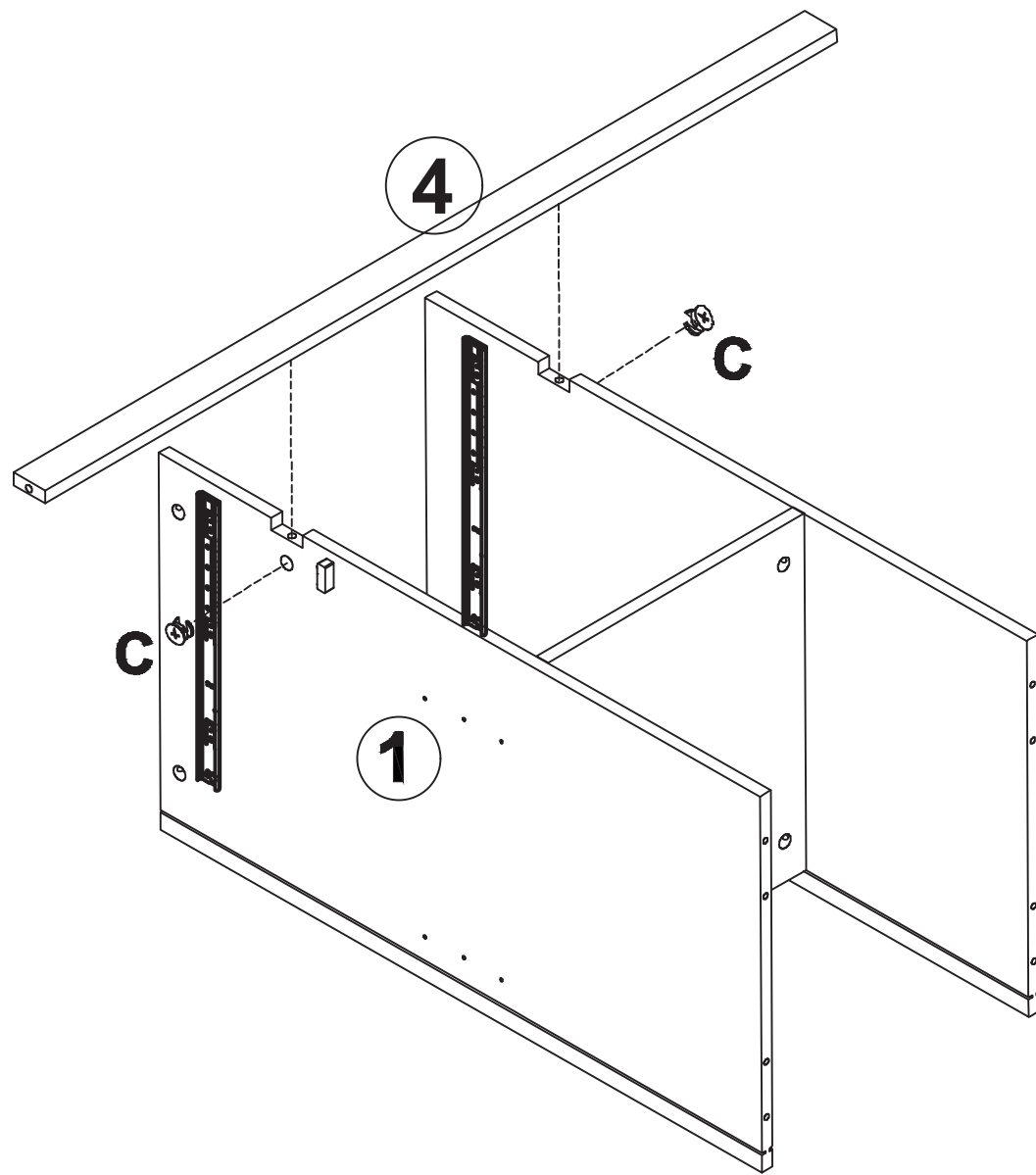



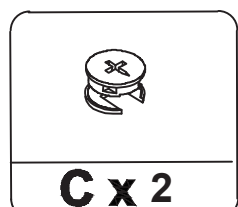
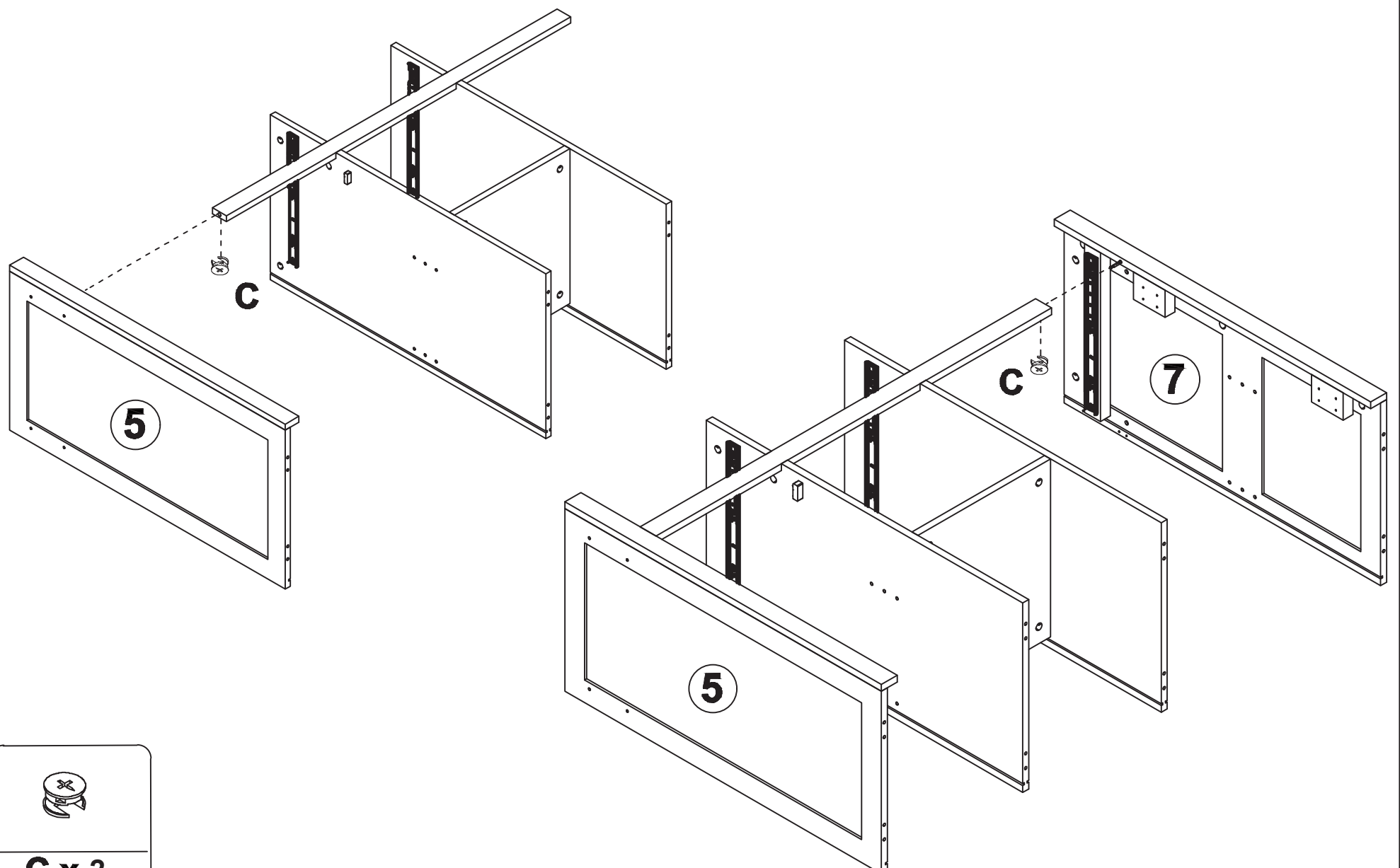

step 7 / étape 7

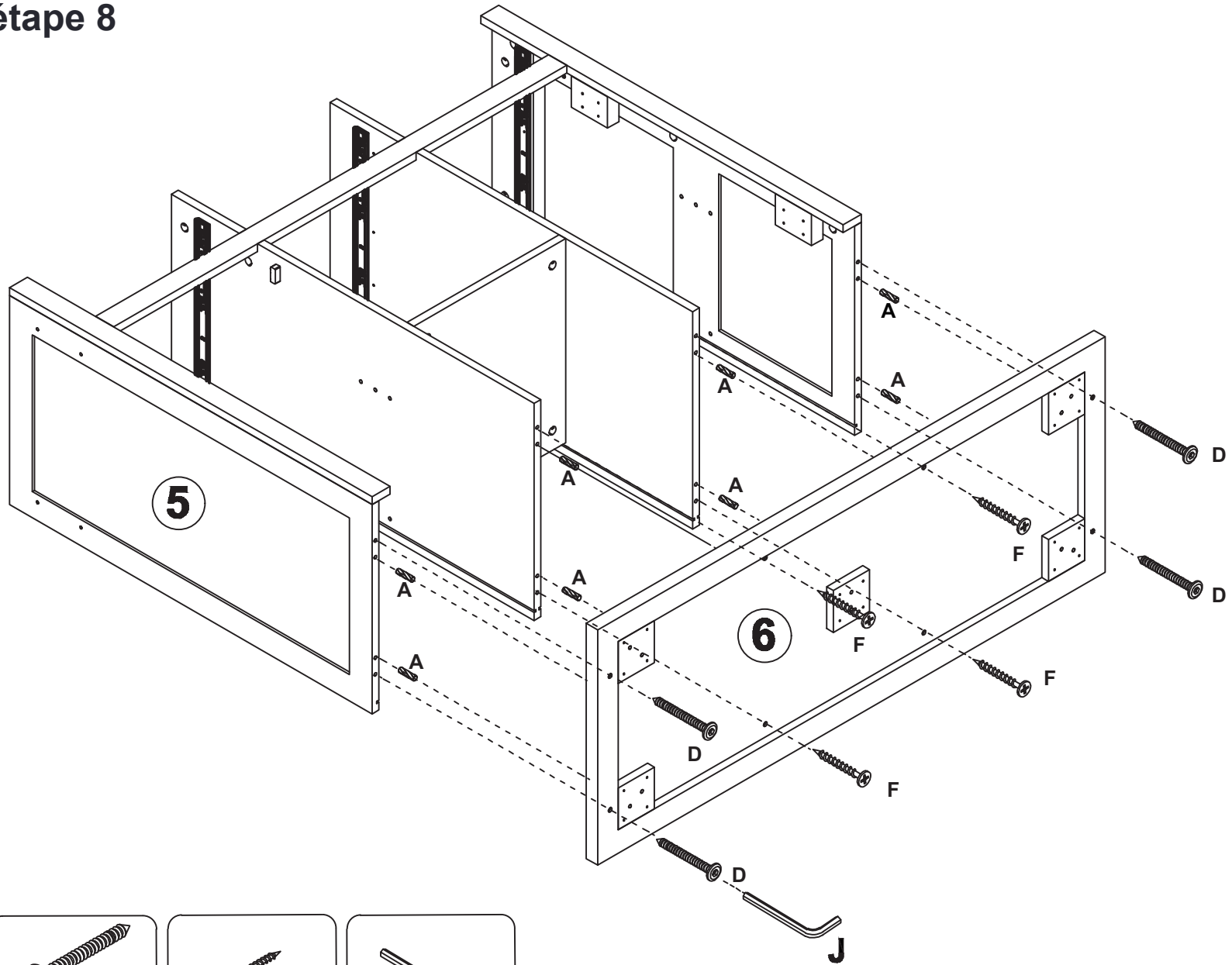

step 8 / étape 8



| | | | |
|--|--|--|---|
|  Φ6x30mm A x 8 |  Φ5x50mm D x 4 |  M4x40mm F x 4 |  J x 1 |
|--|--|--|---|



step 9 / étape 9

Plan 1

or

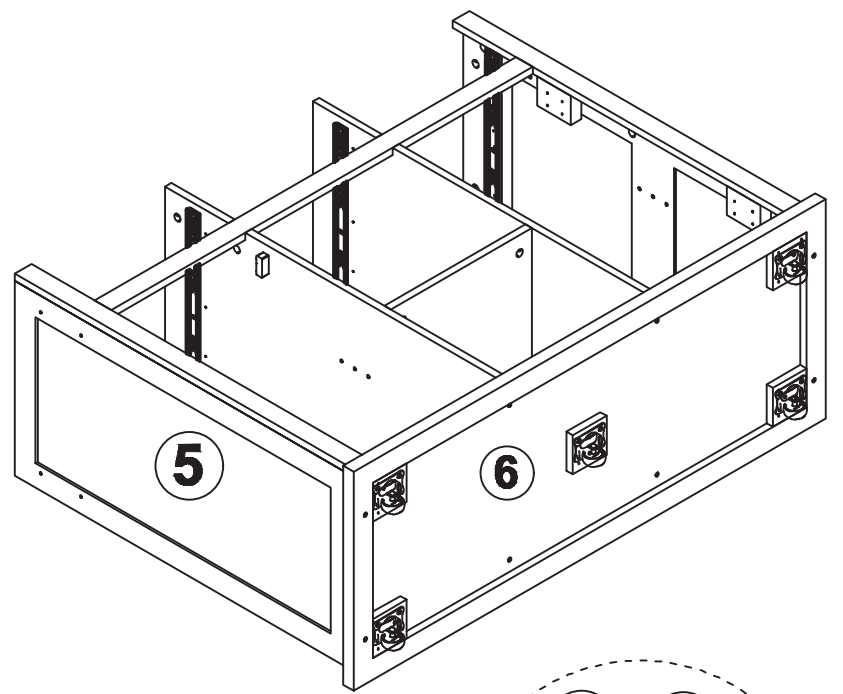
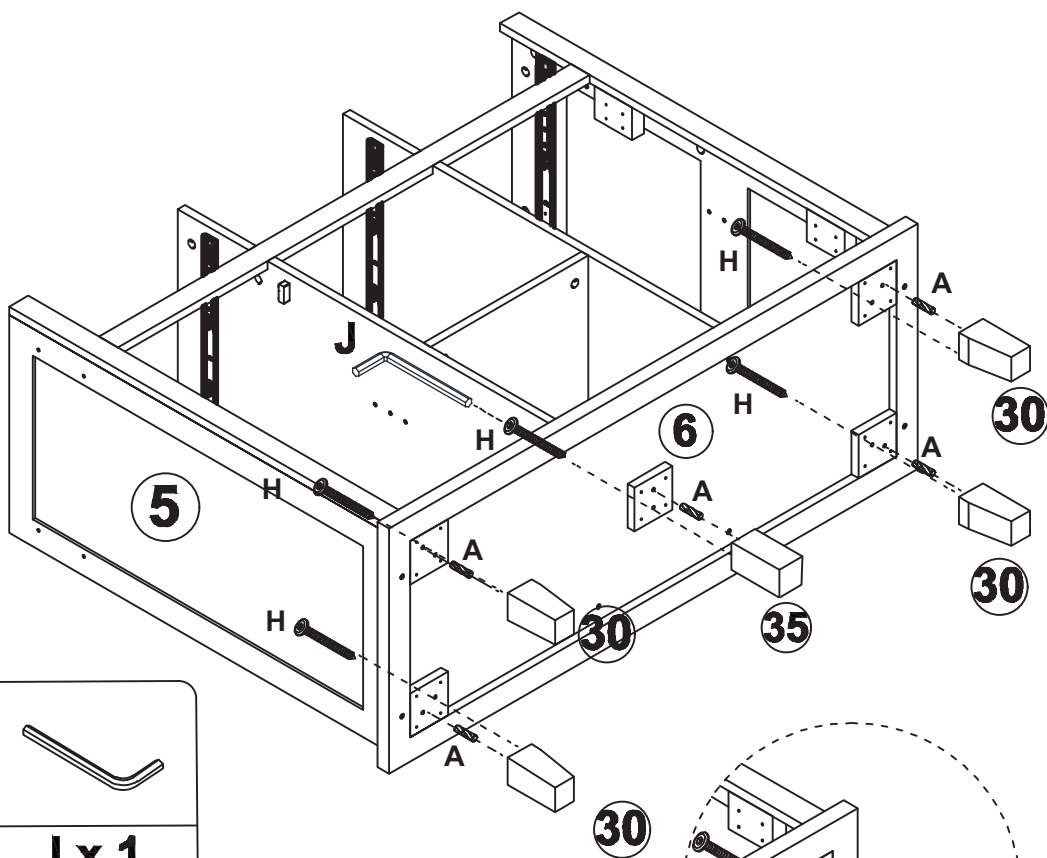

Plan 2

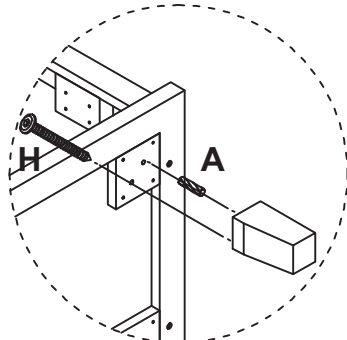

| | |
|--|--|
|  J x 1 |  M5x40mm H x 5 |
|  Φ6x30mm A x 5 | |



| |
|---|
|  Φ5x16mm G x 20 |
|---|

| |
|---|
|  31&36 |
|  G x 20 |

step 10 / étape 10

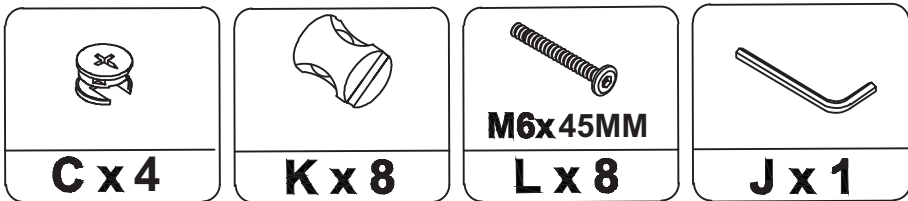
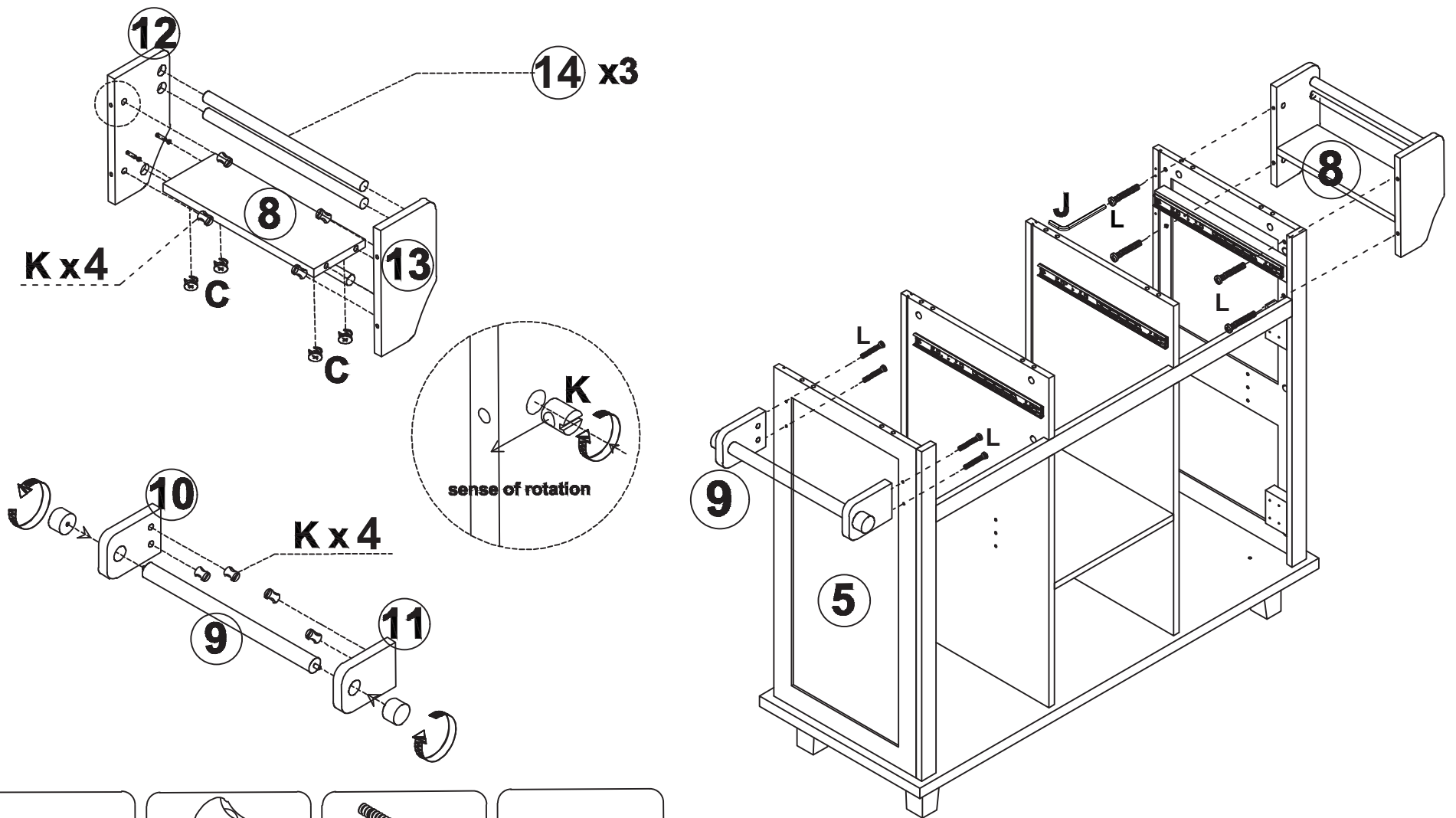

step 11 / étape 11

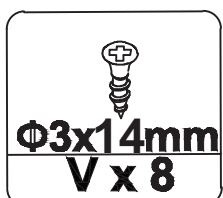
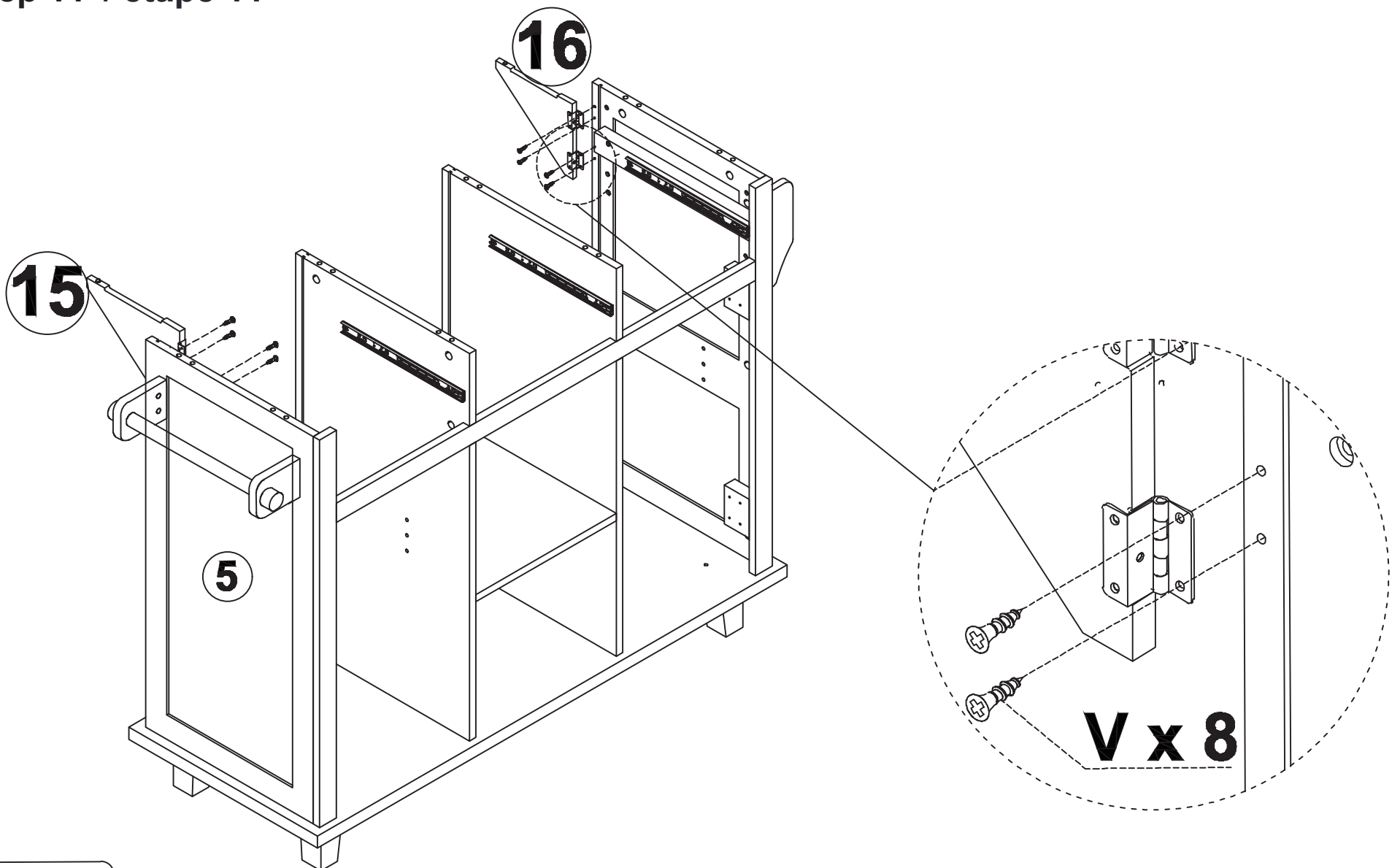

step 12 / étape 12

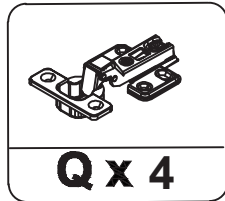
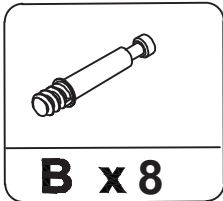
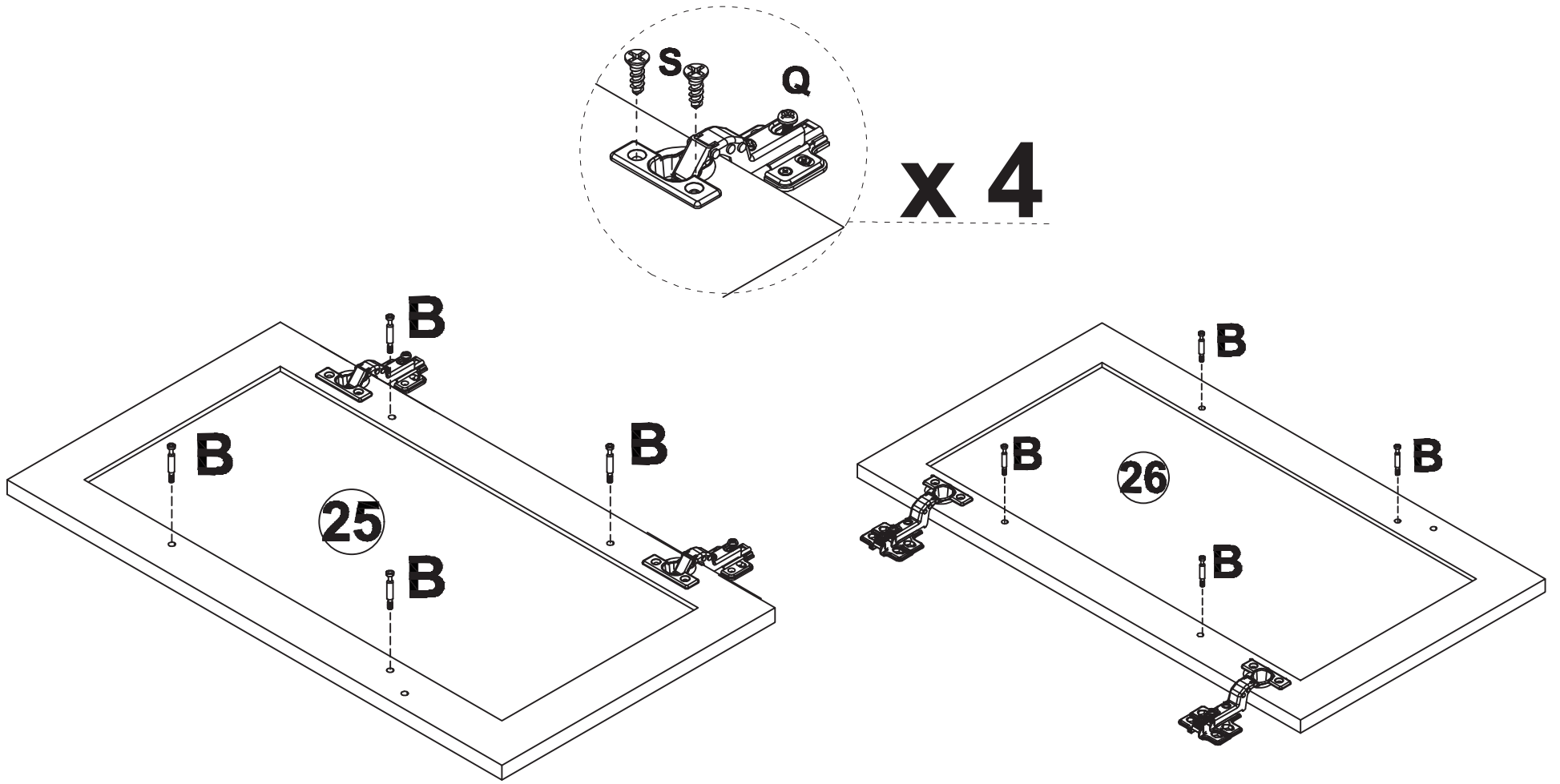

step 13 / étape 13

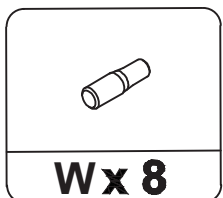
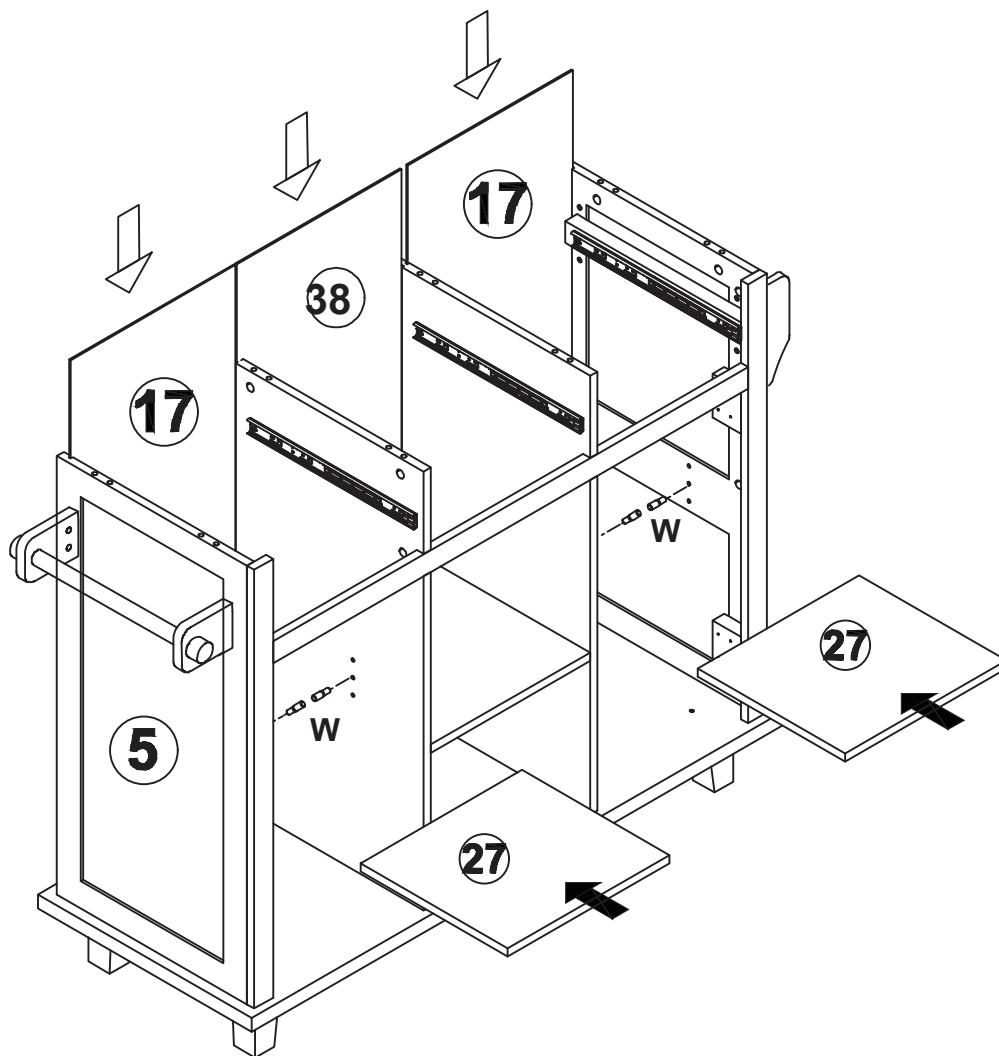

step 14 / étape 14

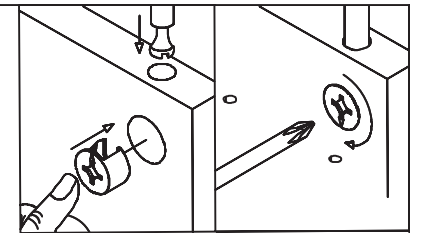
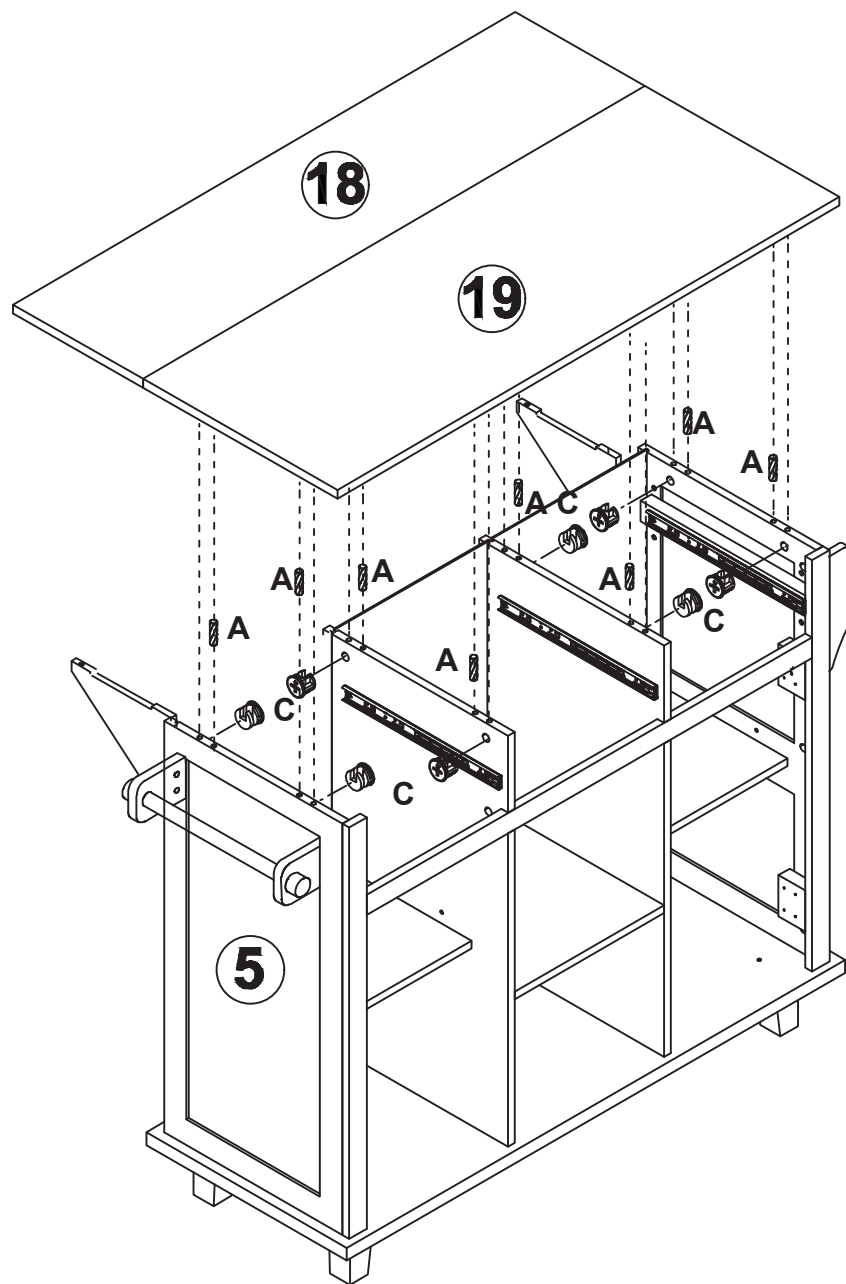

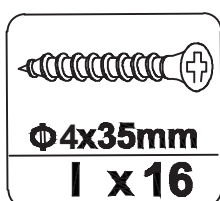
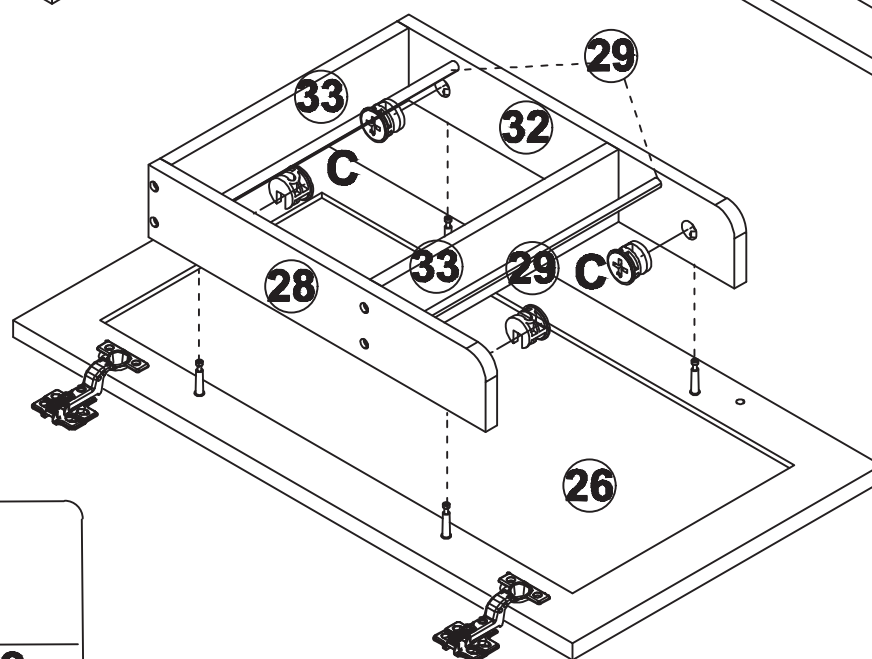
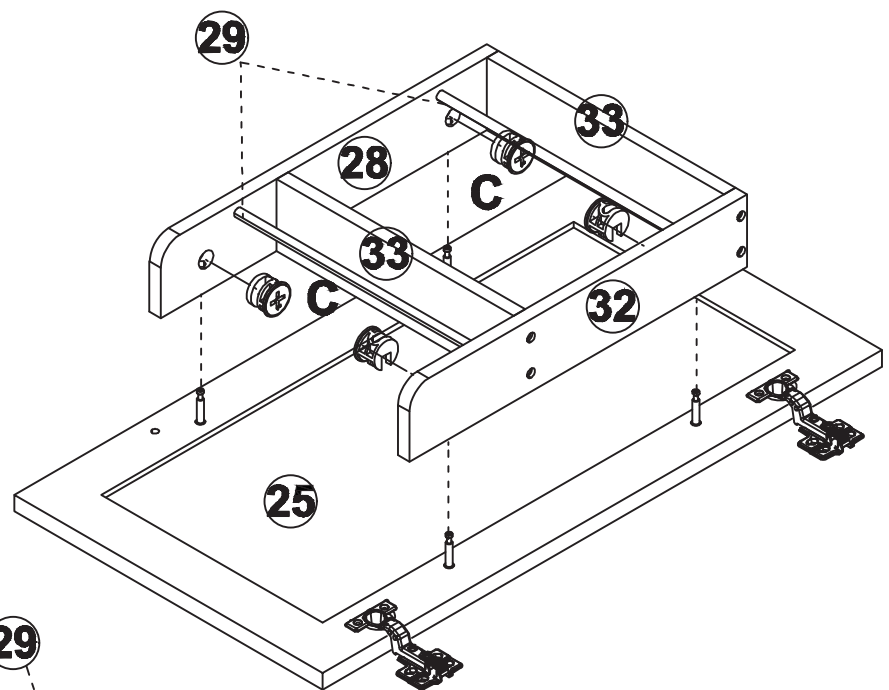
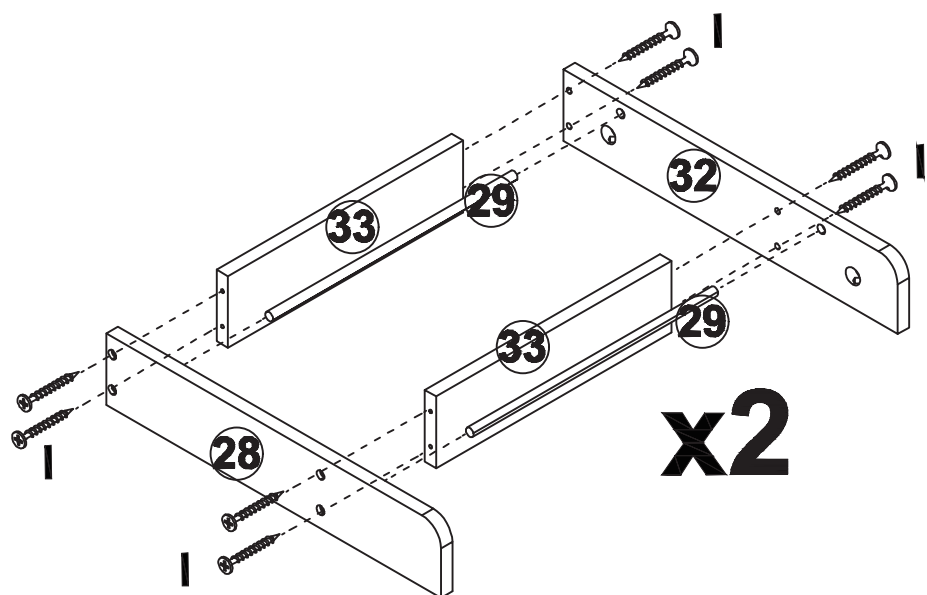

step 15 / étape 15



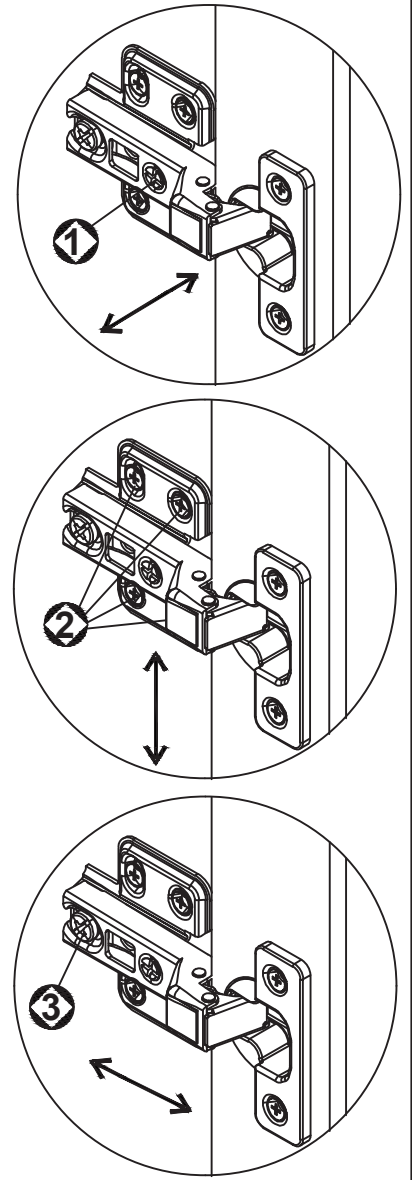
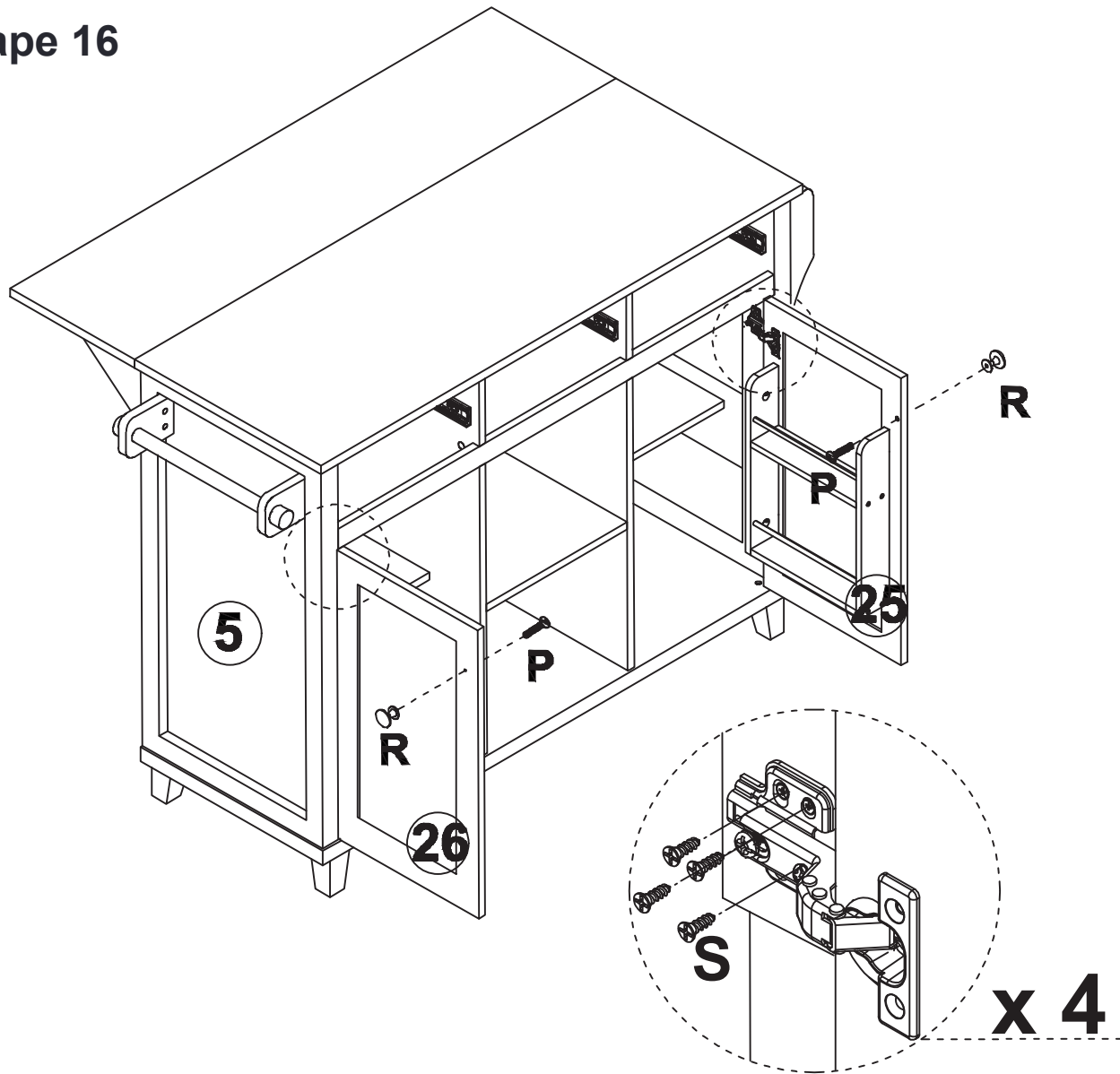





step 16 / étape 16

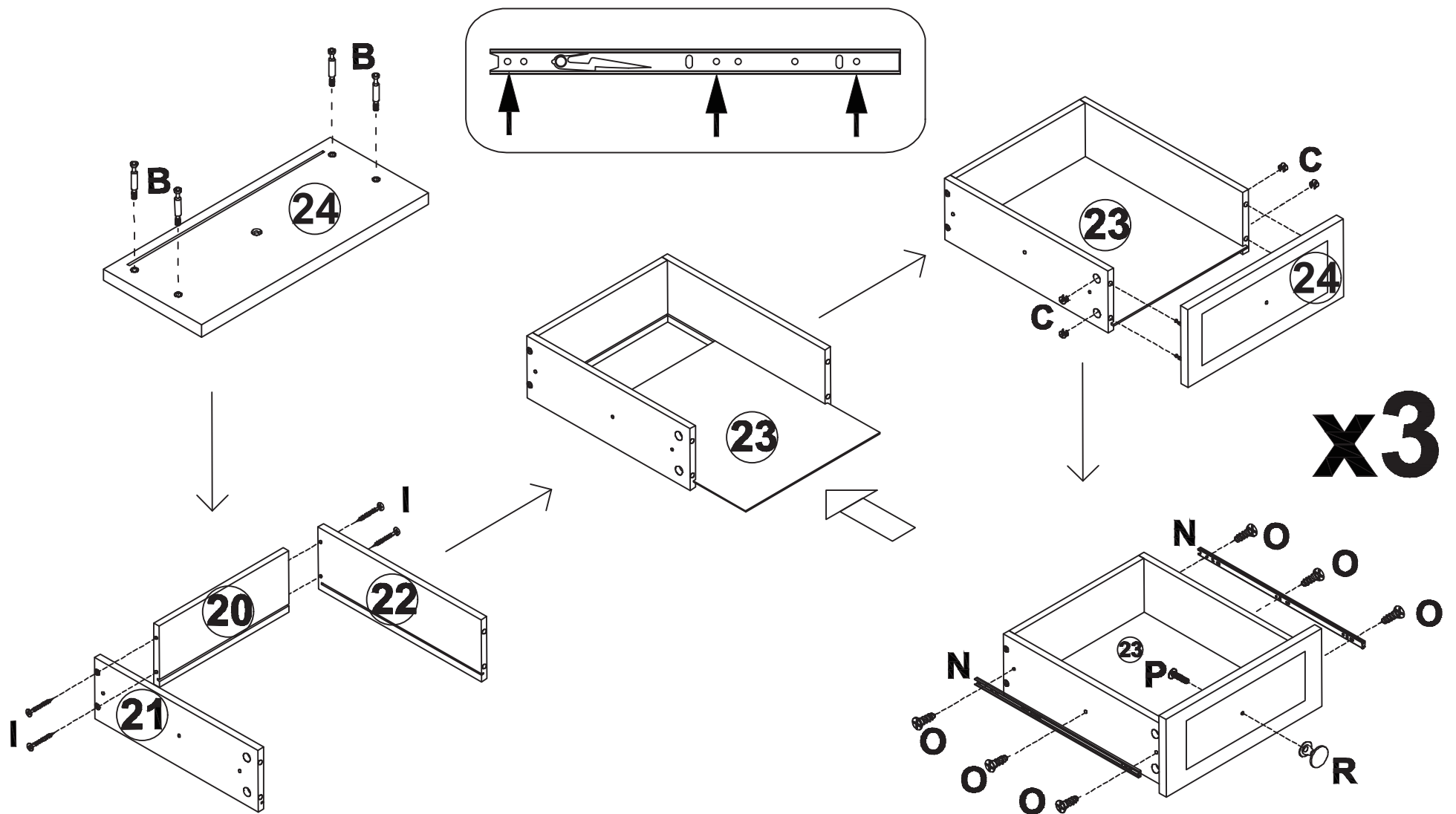

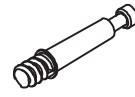
- 
 $\Phi 4 \times 14 \text{mm}$
S x 16
- 
 $\Phi 4 \times 14 \text{mm}$
P x 2
- 
R x 2

step 17 / étape 17



- 
B x 12
- 
C x 12
- 
 $\Phi 4 \times 35 \text{mm}$
I x 12
- 
N x 6
- 
 $\Phi 3 \times 12 \text{mm}$
O x 18
- 
 $\Phi 4 \times 14 \text{mm}$
P x 3
- 
R x 3

step 18 / étape 18

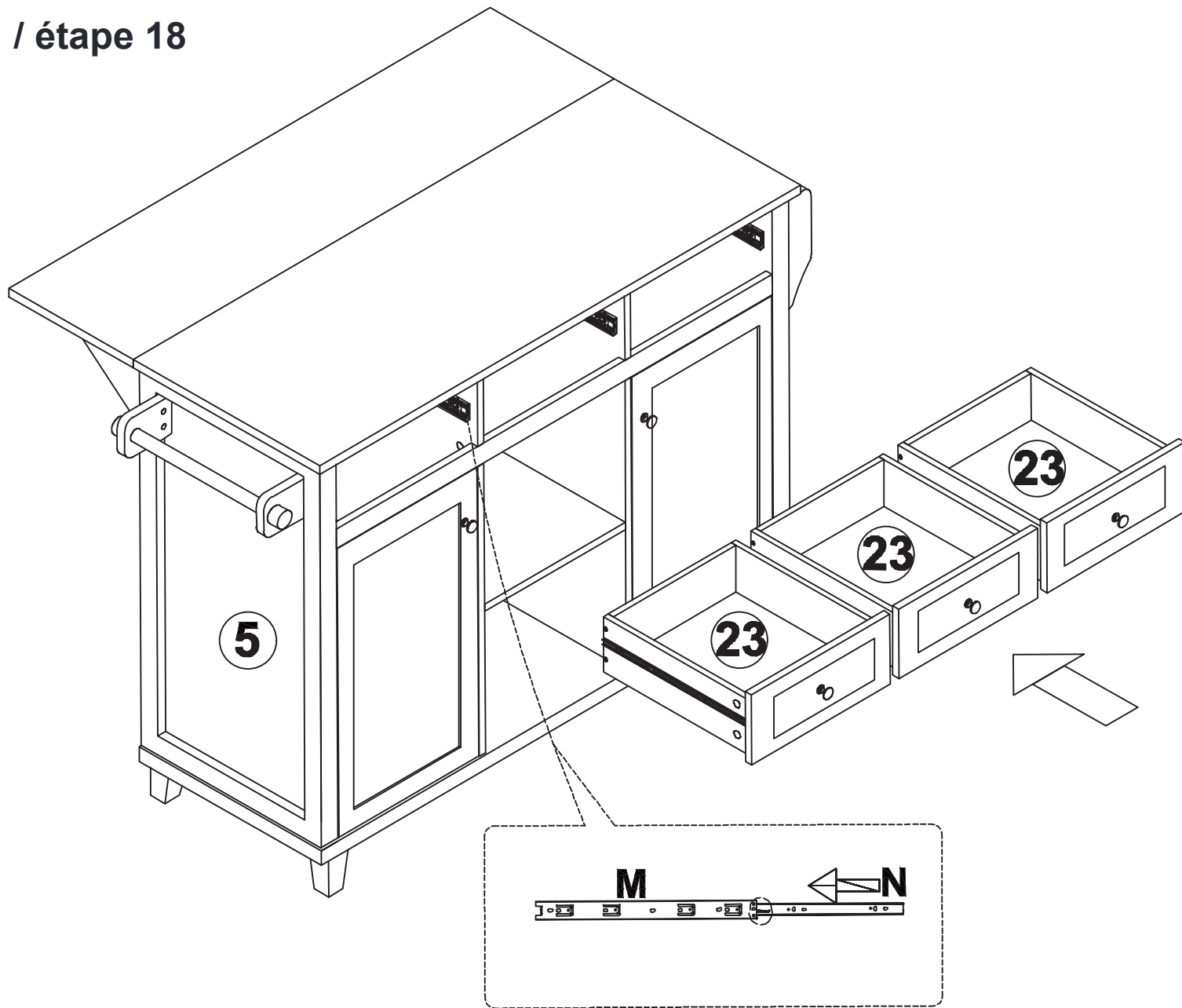

step 19 / étape 19

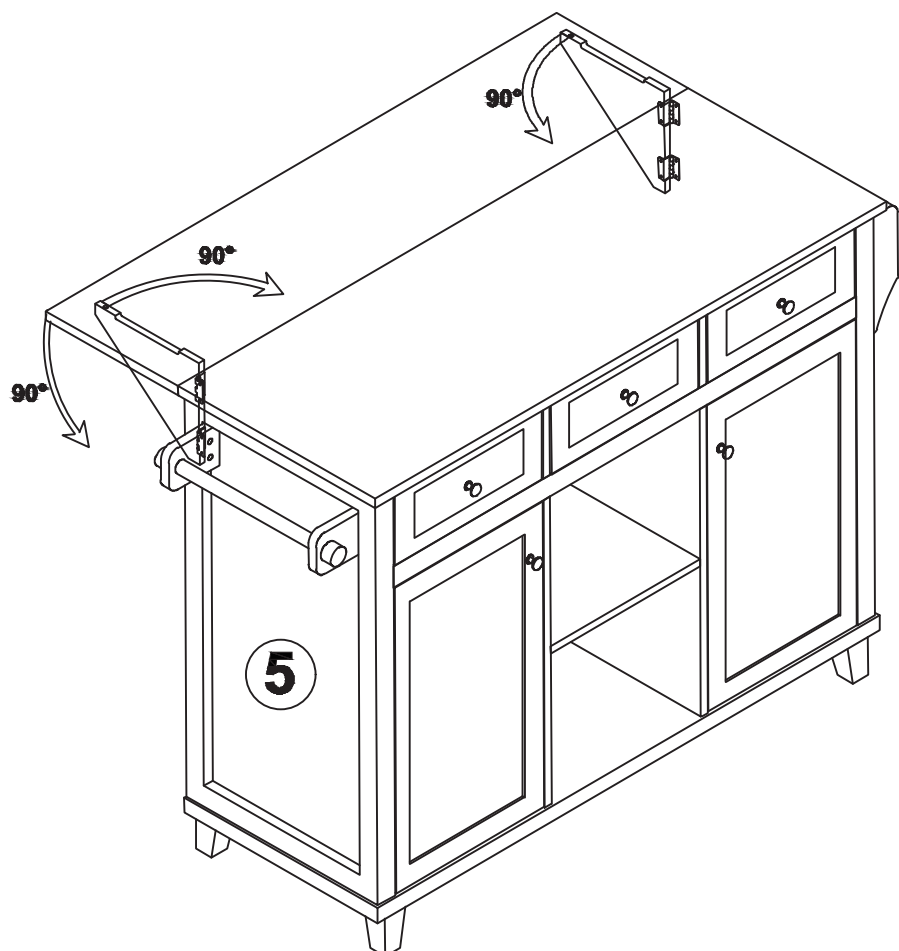

step 20 / étape 20

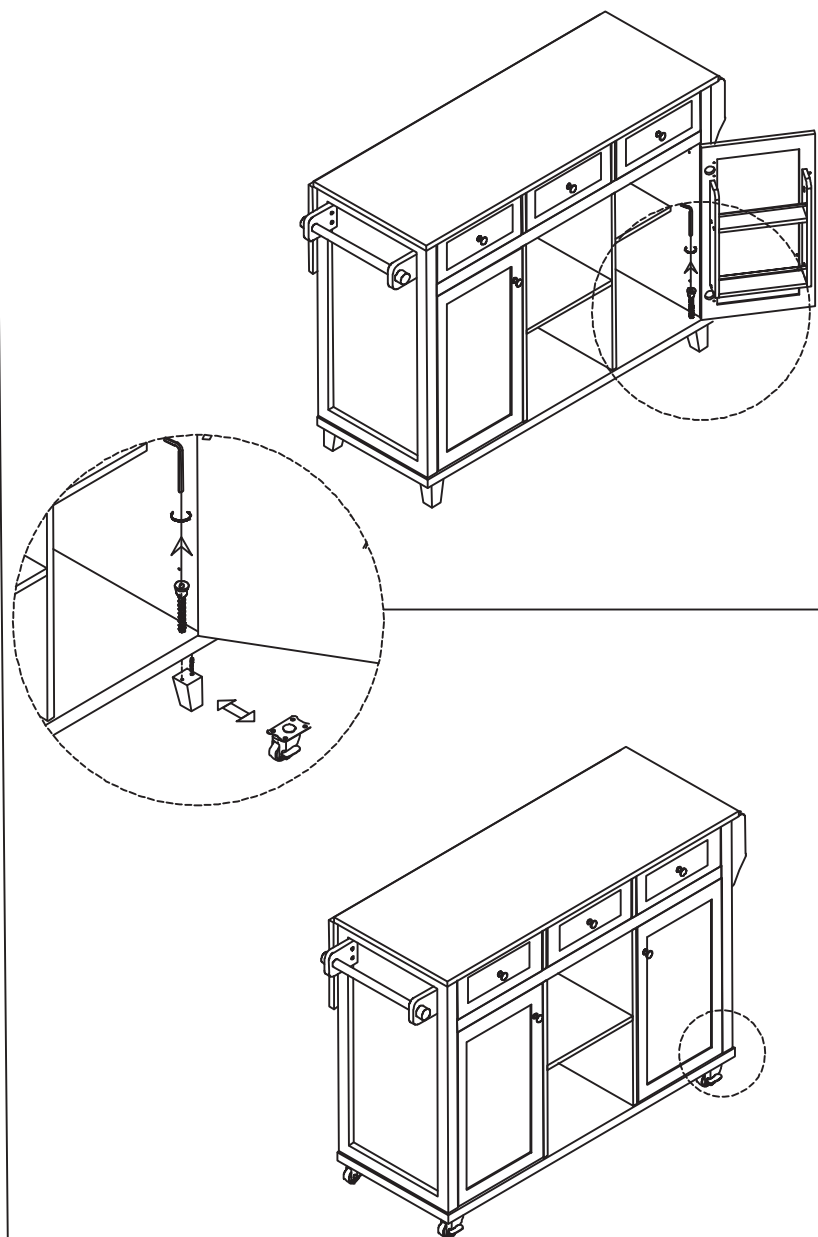

interchangeable

step 21 / étape 21

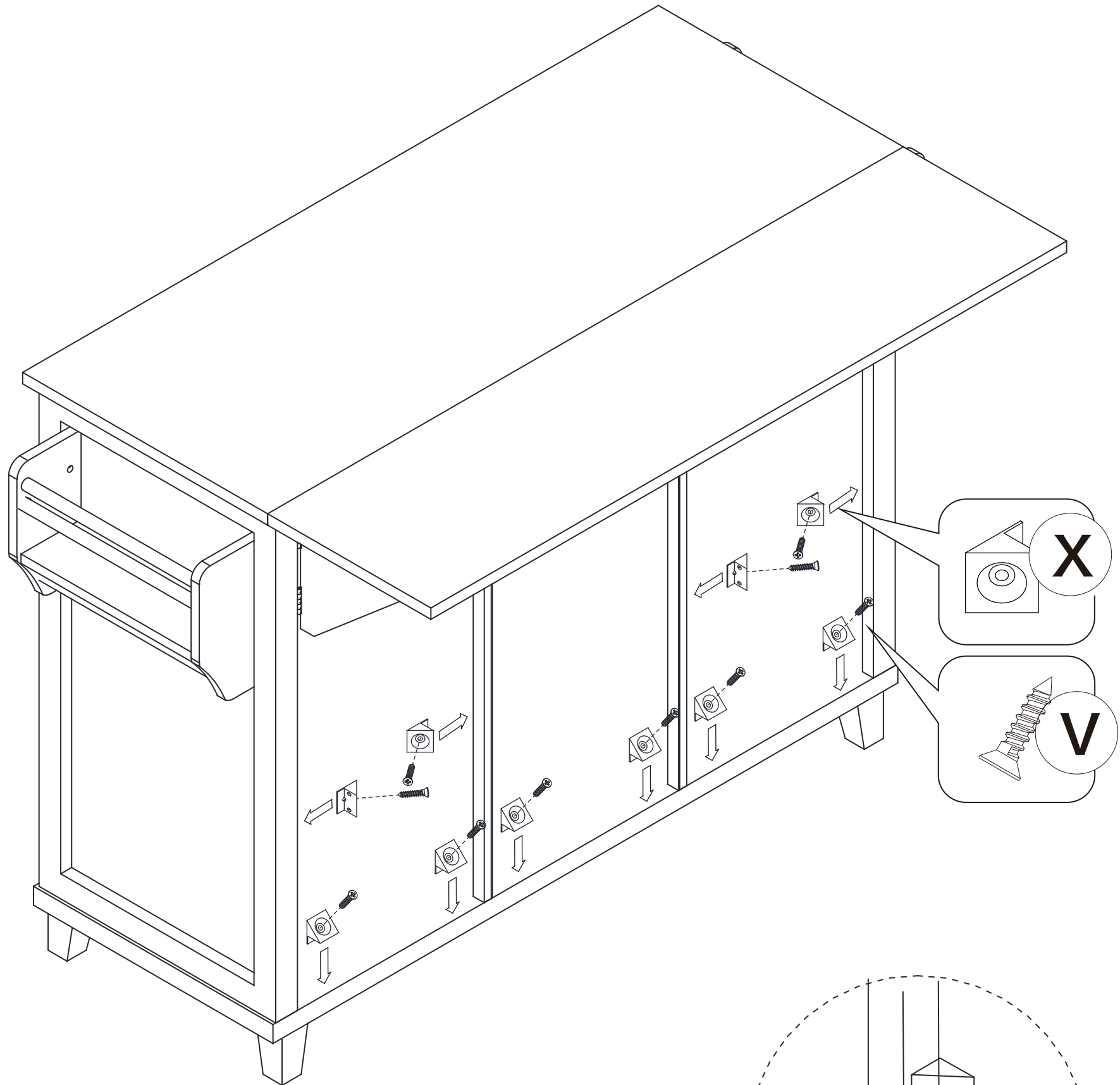

The Backboard Buckle K serves to assist in stabilizing the backboard structure. You can choose to install or not to install at will. This product can be used normally. When you choose to install it, you can directly screw in the screw V at the gap of the backboard.

La boucle K du dos sert à stabiliser la structure du dos. Vous pouvez choisir d'installer ou de ne pas installer à volonté. Ce produit peut être utilisé normalement. Lorsque vous choisissez de l'installer, vous pouvez visser directement la vis V à l'interstice du dos.

