

# ASSEMBLY INSTRUCTION

## ITEM: N852P425927W

**Important note:**

1. Place all wooden parts on a clean and smooth surface such as a rug or carpet to avoid scratching the parts.
2. Kindly follow the assembly instructions step by step.
3. Do not tighten all screws and bolts until the table is fully assembled.
4. Unscrew the protective plastique supports from the metal insert of the legs before assembly.

### PARTS IDENTIFICATION

**A** Chair Back

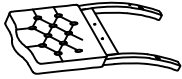

1pc

**B** Seat cushion

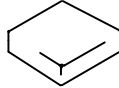

1pc

**C** Left Leg

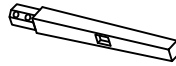

1pc

**D** Right Leg

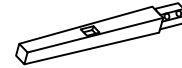

1pc

**E** Left Stretcher

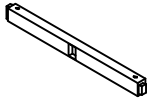

1pc

**F** Right Stretcher

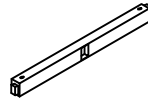

1pc

**G** Center Stretcher

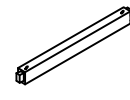



1pc

### HARDWARE IDENTIFICATION

- 1** Bolt  
Ø5/16"X38mm  
 2pcs

- 2** Long Bolt  
Ø5/16"X50mm  
 4pcs

- 3** Bolt  
Ø5/16"X80mm  
 4pcs

- 4** Spring Washer  
Ø5/16"X11mm  
 10 pcs

- 5** Flat Washer  
Ø5/16"X19mm  
 10 pcs

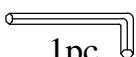
- 6** Allen Key  
M4  
 1pc

- 7** Wood screw  
#8X38mm  
 6pcs

### STEP 1

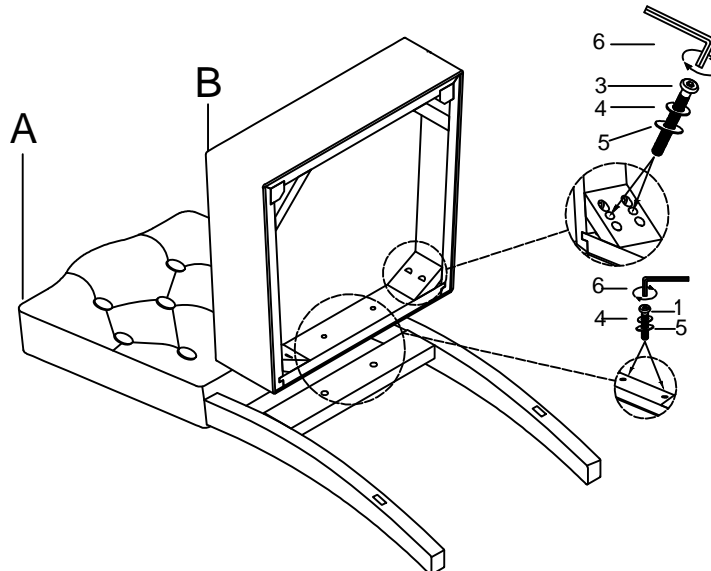

# ASSEMBLY INSTRUCTION

## ITEM: N852P425927W

### STEP 2

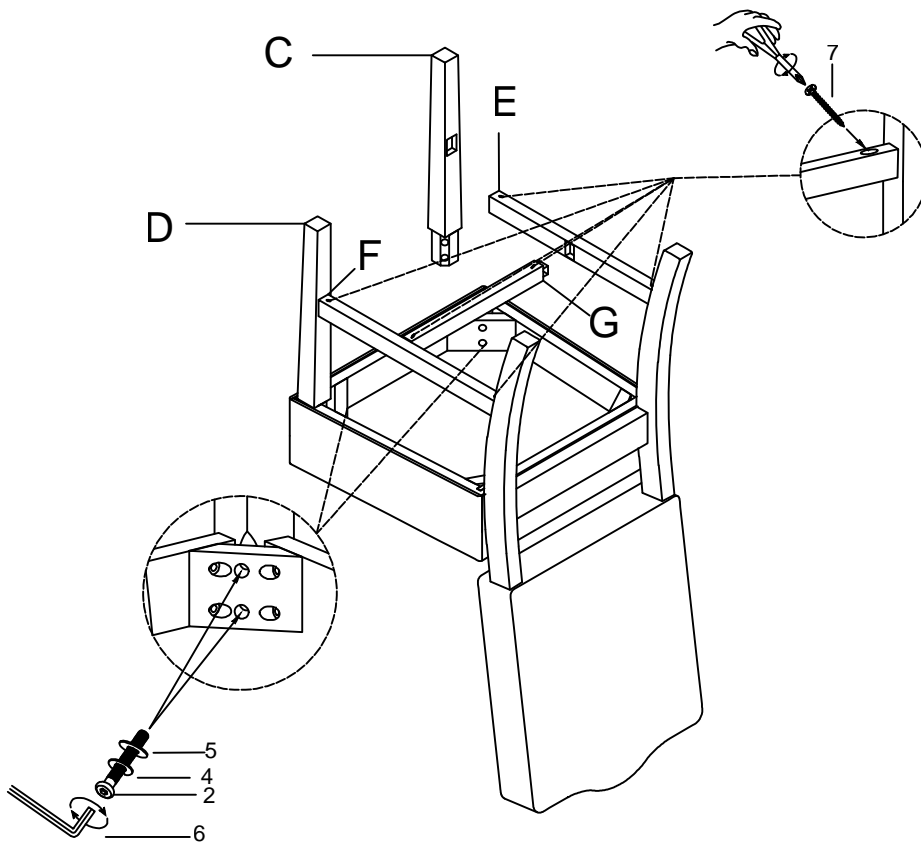

### COMPLETE

