

Installation Instruction

Instruction d'installation

N854P404592



PARTS LIST/ LISTE DES PIÈCES

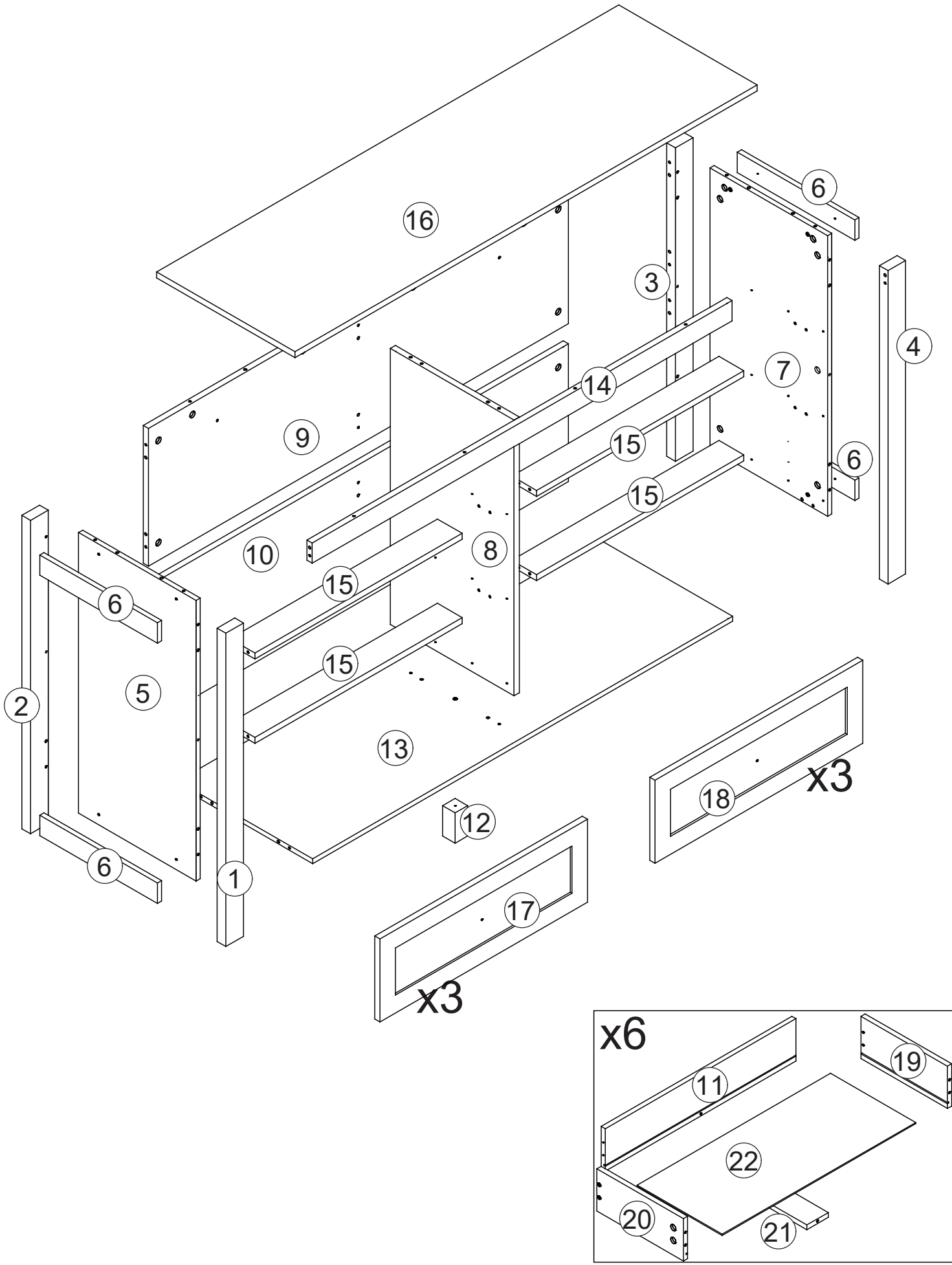

PARTS LIST/ LISTE DES PIÈCES

① X1

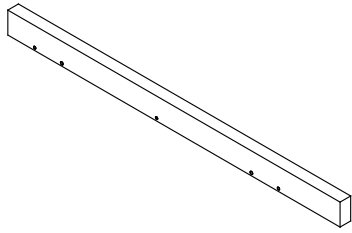

Left front foot
Pied avant gauche

② X1

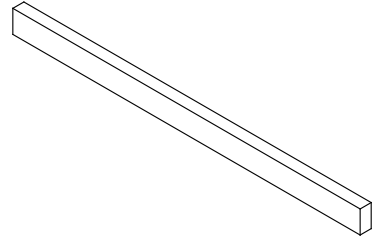

Left hind foot
Pied arrière gauche

③ X1

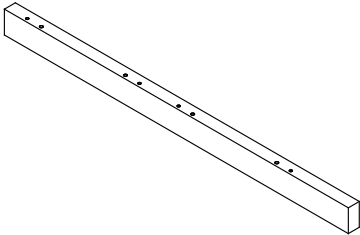

Right hind foot
Pied arrière droit

④ X1

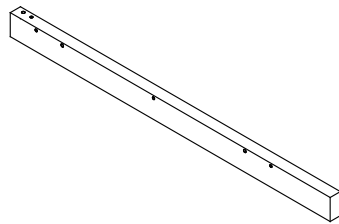

Right front foot
Pied avant droit

⑤ X1

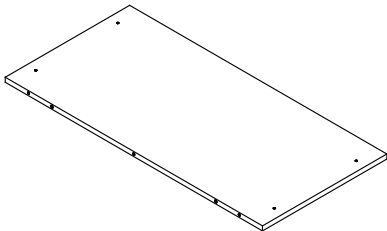

Left side panel
Panneau latéral gauche

⑥ X4

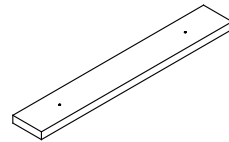

Side panel strip
Lanière de panneau latéral

⑦ X1

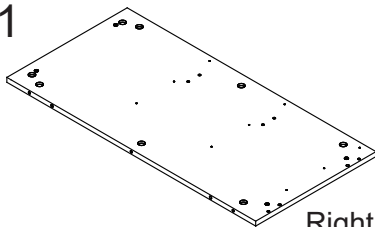

Right side panel
Panneau latéral droit

⑧ X1

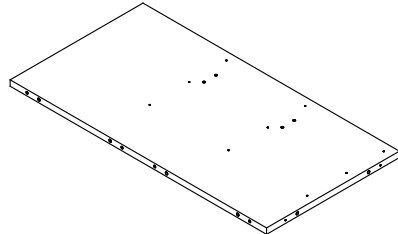

Middle vertical panel
Panneau vertical central

⑨ X1

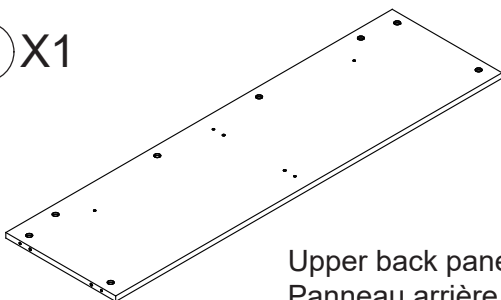

Upper back panel
Panneau arrière supérieur

⑩ X1

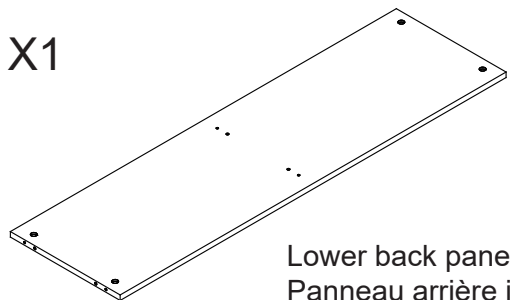

Lower back panel
Panneau arrière inférieur

⑪ X6

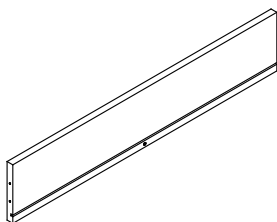

Drawer back panel
Panneau arrière du tiroir

⑫ X1

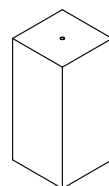

Middle foot
Pied central

13 X1

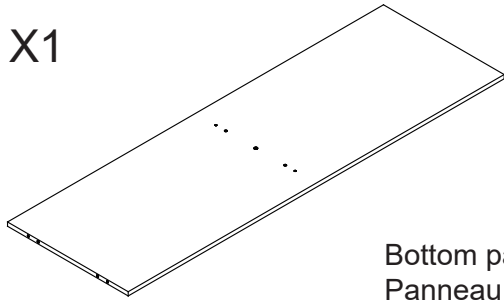

Bottom panel
Panneau de fond

14 X1

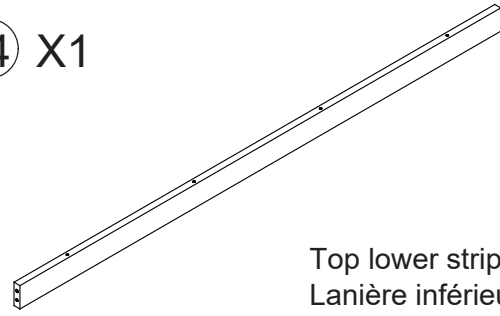

Top lower strip
Lanière inférieure du toit

15 X4

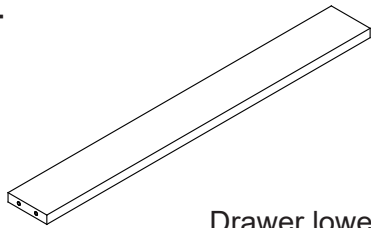

Drawer lower strip
Lanière inférieure du tiroir

16 X1

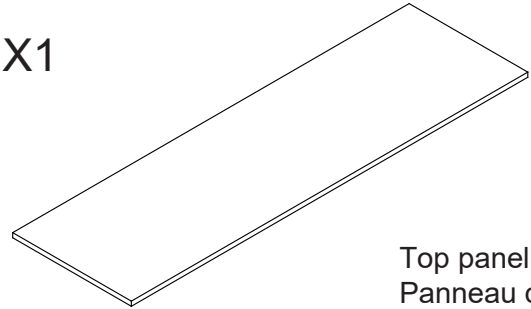

Top panel
Panneau de toit

17 X3

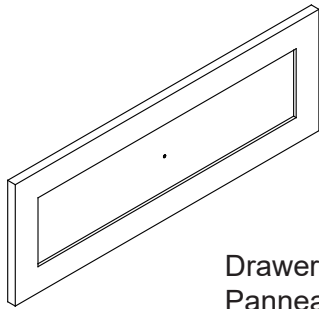

Drawer front panel
Panneau avant du tiroir

18 X3

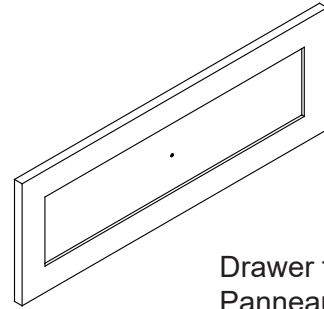

Drawer front panel
Panneau avant du tiroir

19 X6

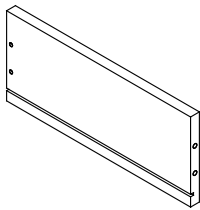

Drawer side panel
Panneau latéral du tiroir

20 X6

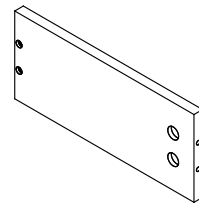

Drawer side panel
Panneau latéral du tiroir

21 X6

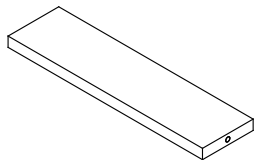

Drawer bottom strip
Lanière de fond du tiroir



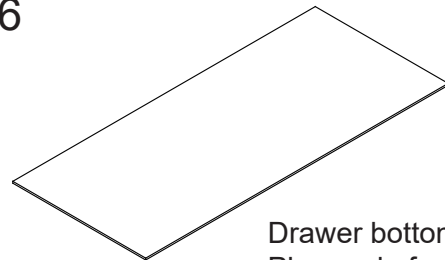





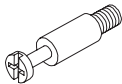

22 X6

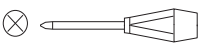
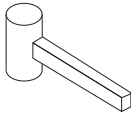

Drawer bottom panel
Plaque de fond du tiroir

Hardware:/Matériel:

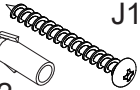
ASSEMBLY TOOLS REQUIRED (NOT INCLUDED)
 OUTILS D'ASSEMBLAGE REQUIS (NON INCLUS)

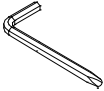
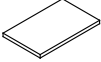
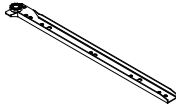
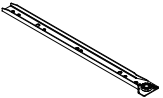
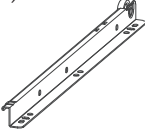
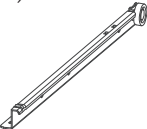
<p>A 6*35 mm</p>  <p>x86+2</p>	<p>B 15*10 mm</p>  <p>x86+2</p>	<p>C 6*30 mm</p>  <p>x36+2</p>	<p>Screwdriver</p>  <p>Hammer</p> 	
<p>D 4*8 mm</p>  <p>x6</p>	<p>E 3.5*12 mm</p>  <p>x60+2</p>	<p>F 4*40 mm</p>  <p>x7+1</p>	<p>G</p>  <p>x1</p>	<p>H 4*20 mm</p>  <p>x8+1</p>
<p>I M4*30mm</p>  <p>x30+2</p>	<p>J M4*50mm</p> <p>J1</p>  <p>J2</p>  <p>x2</p>	<p>K</p>  <p>x1</p>	<p>L</p>  <p>x4</p>	<p>(CL)</p>  <p>x6</p>
<p>(CR)</p>  <p>x6</p>	<p>(DL)</p>  <p>x6</p>	<p>(DR)</p>  <p>x6</p>		

Step 1/Étapes 1

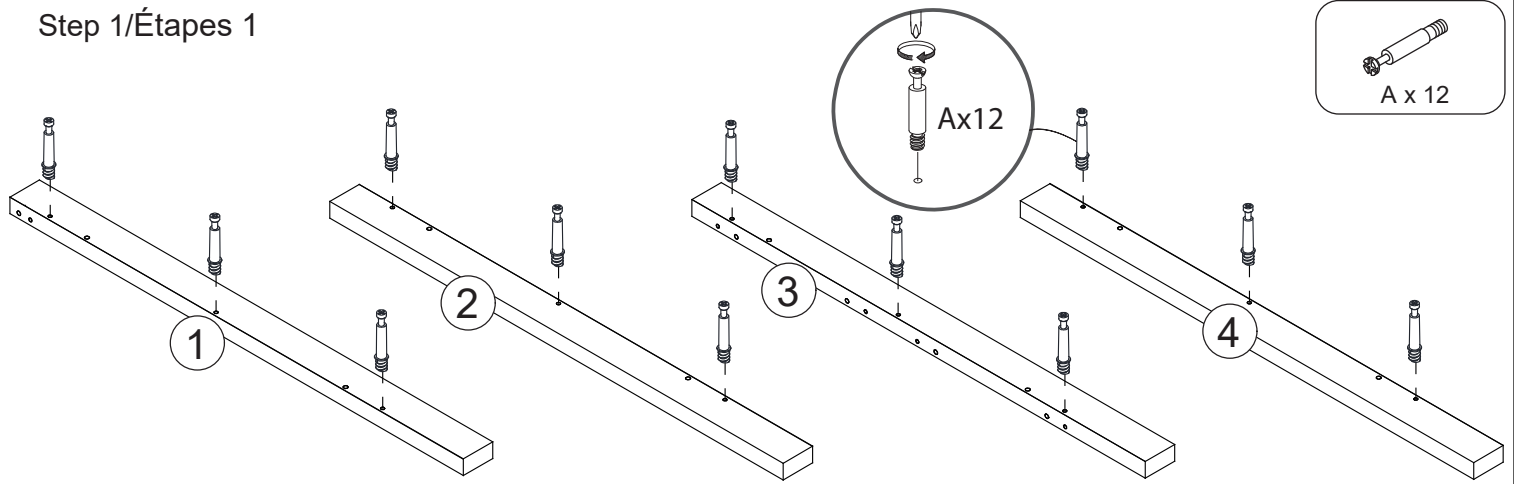

Step 2/Étapes 2

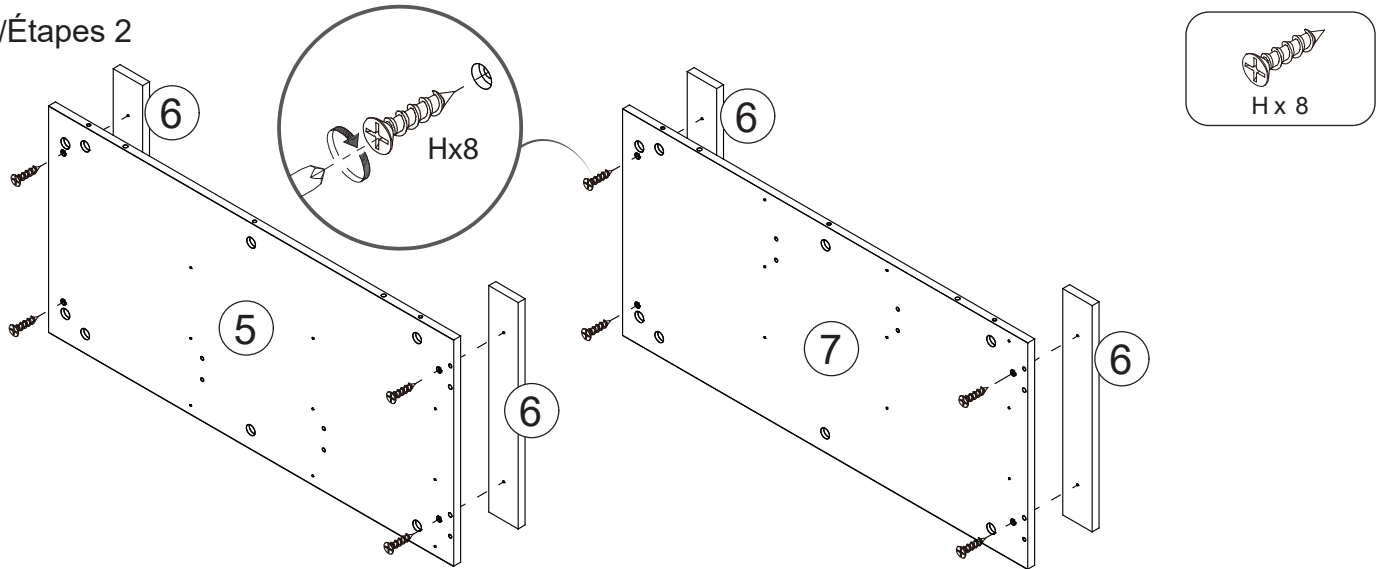

Step 3/Étapes 3

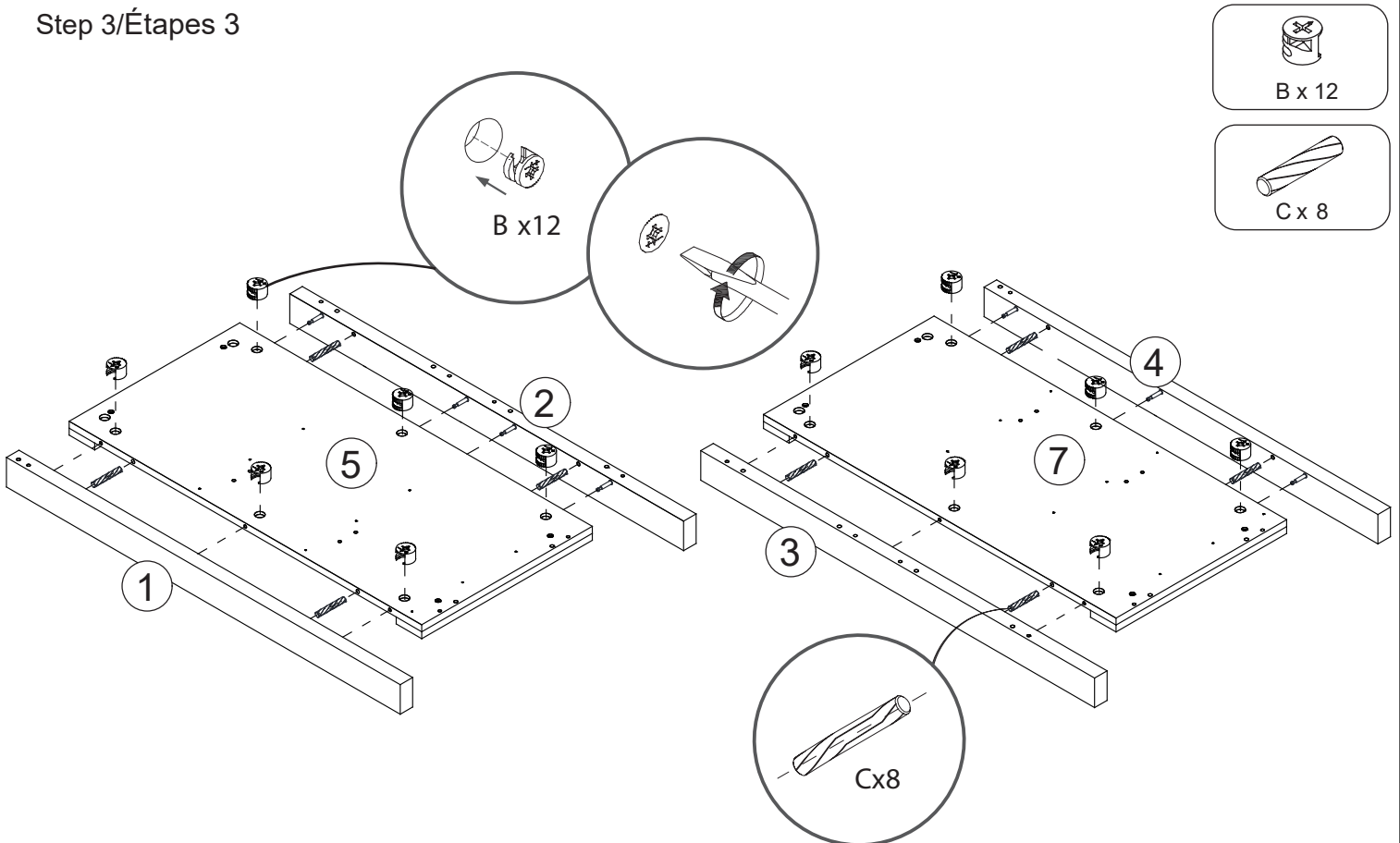

Step 4/Étapes 4

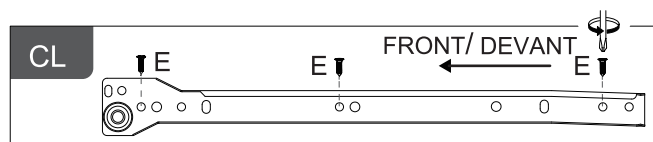
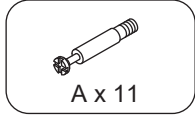
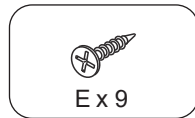
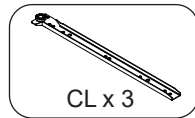
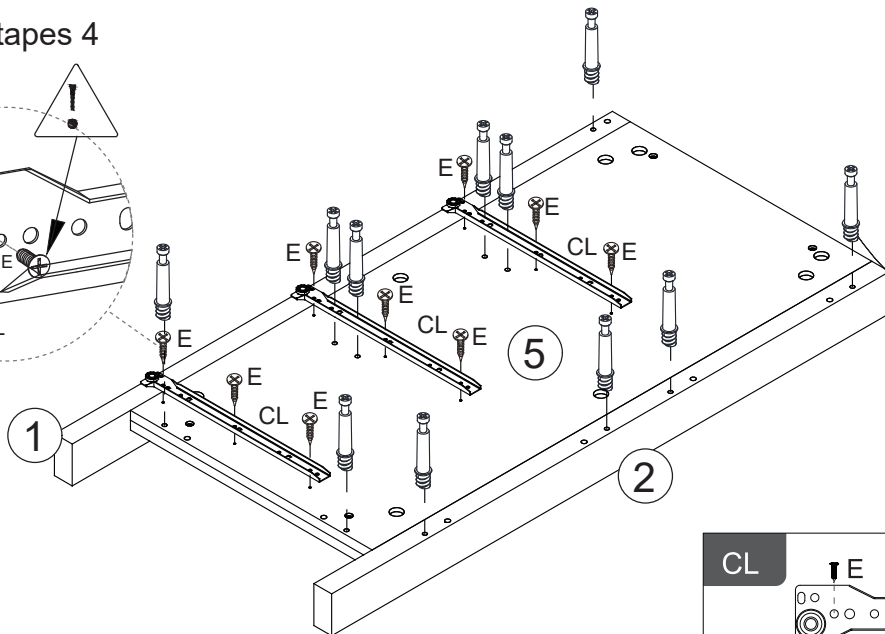
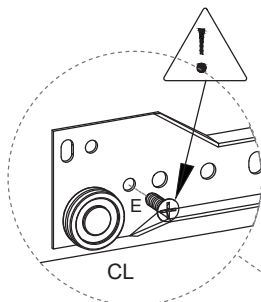

Step 5/Étapes 5

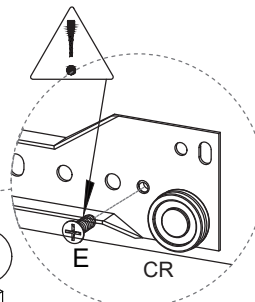
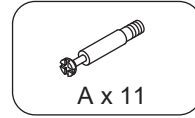
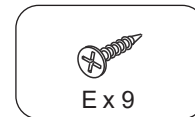
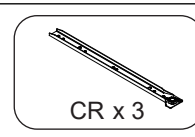
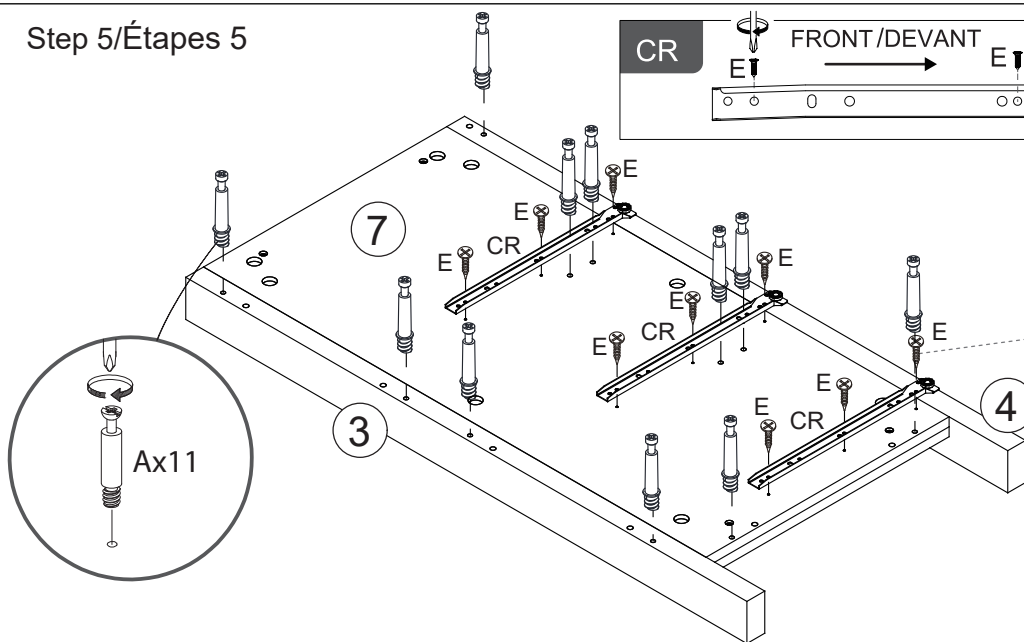
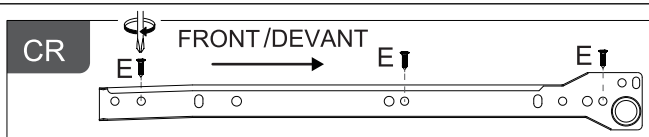

Step 6/Étapes 6

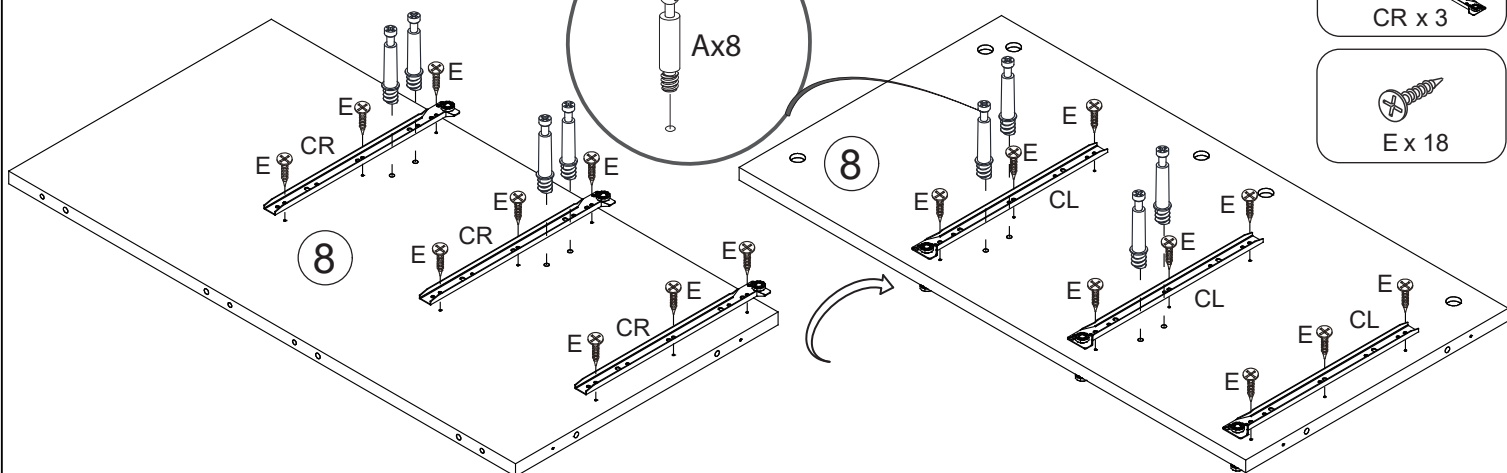
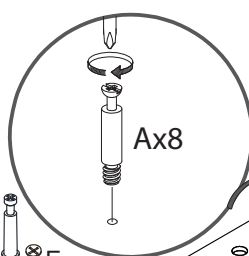
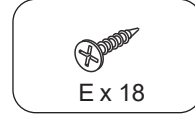
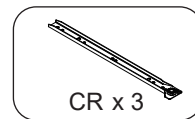
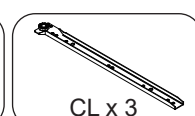
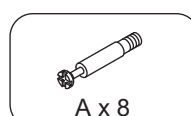
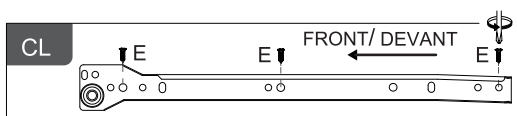
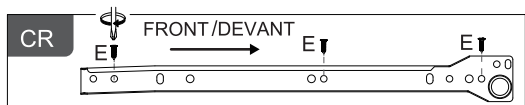

Step 7/Étapes 7

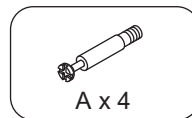
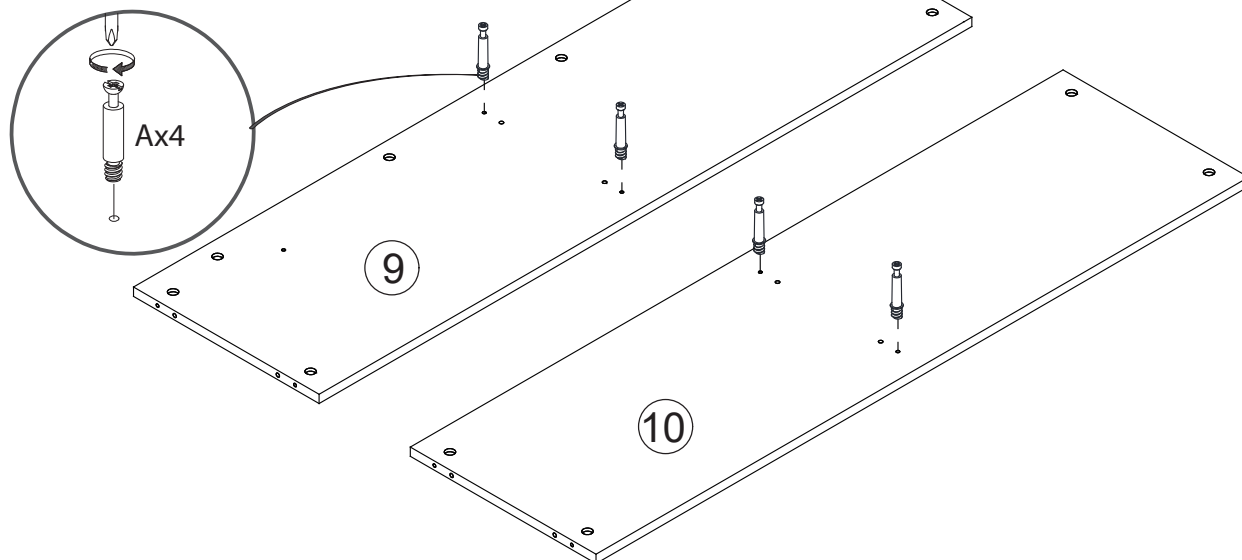

Step 8/Étapes 8

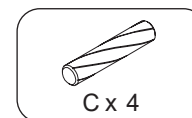
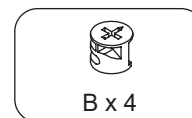
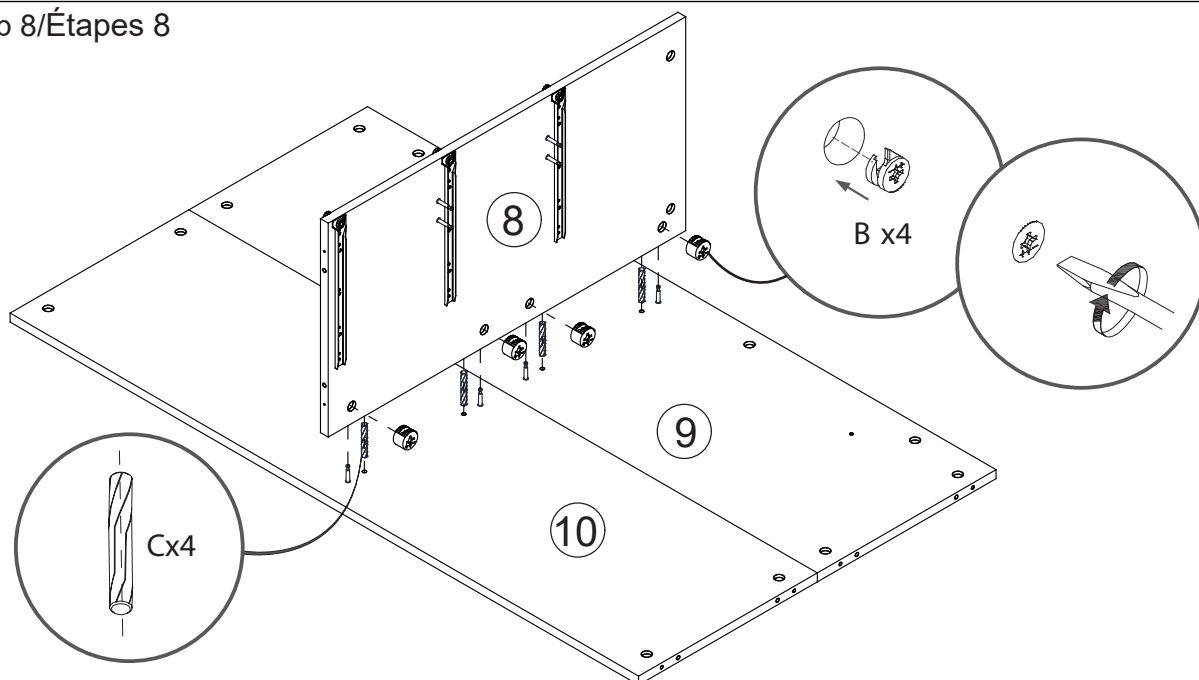

Step 9/Étapes 9

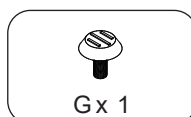
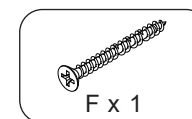
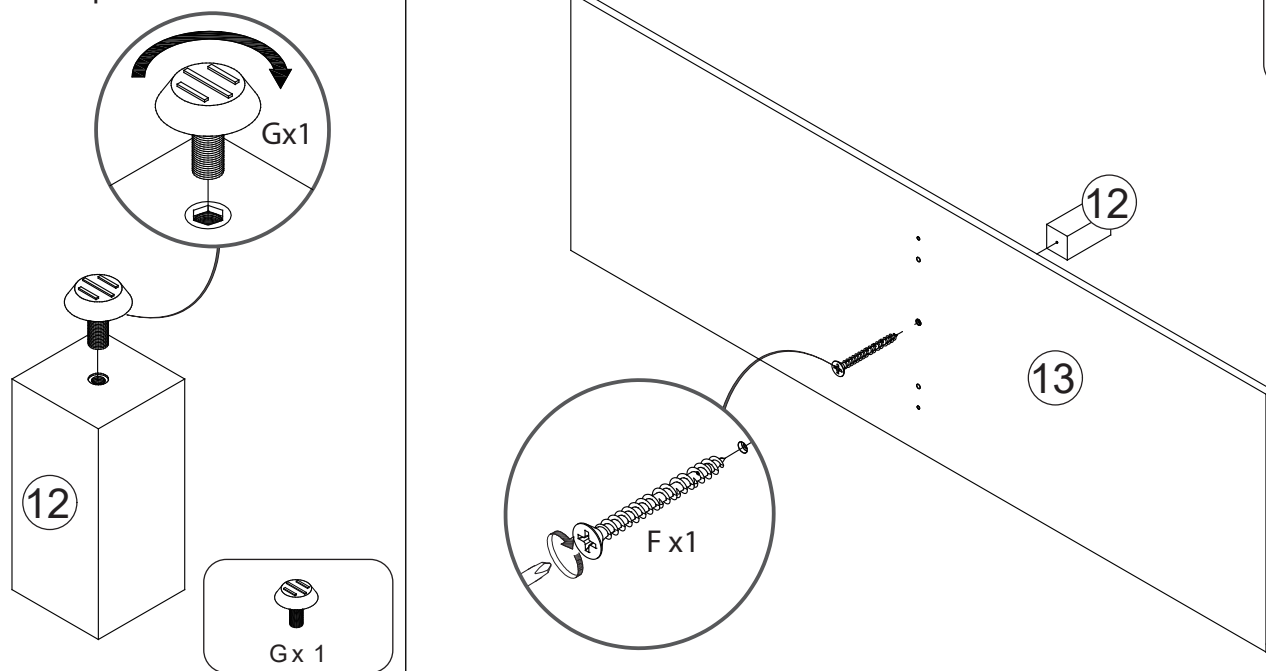

Step 10/Étapes 10

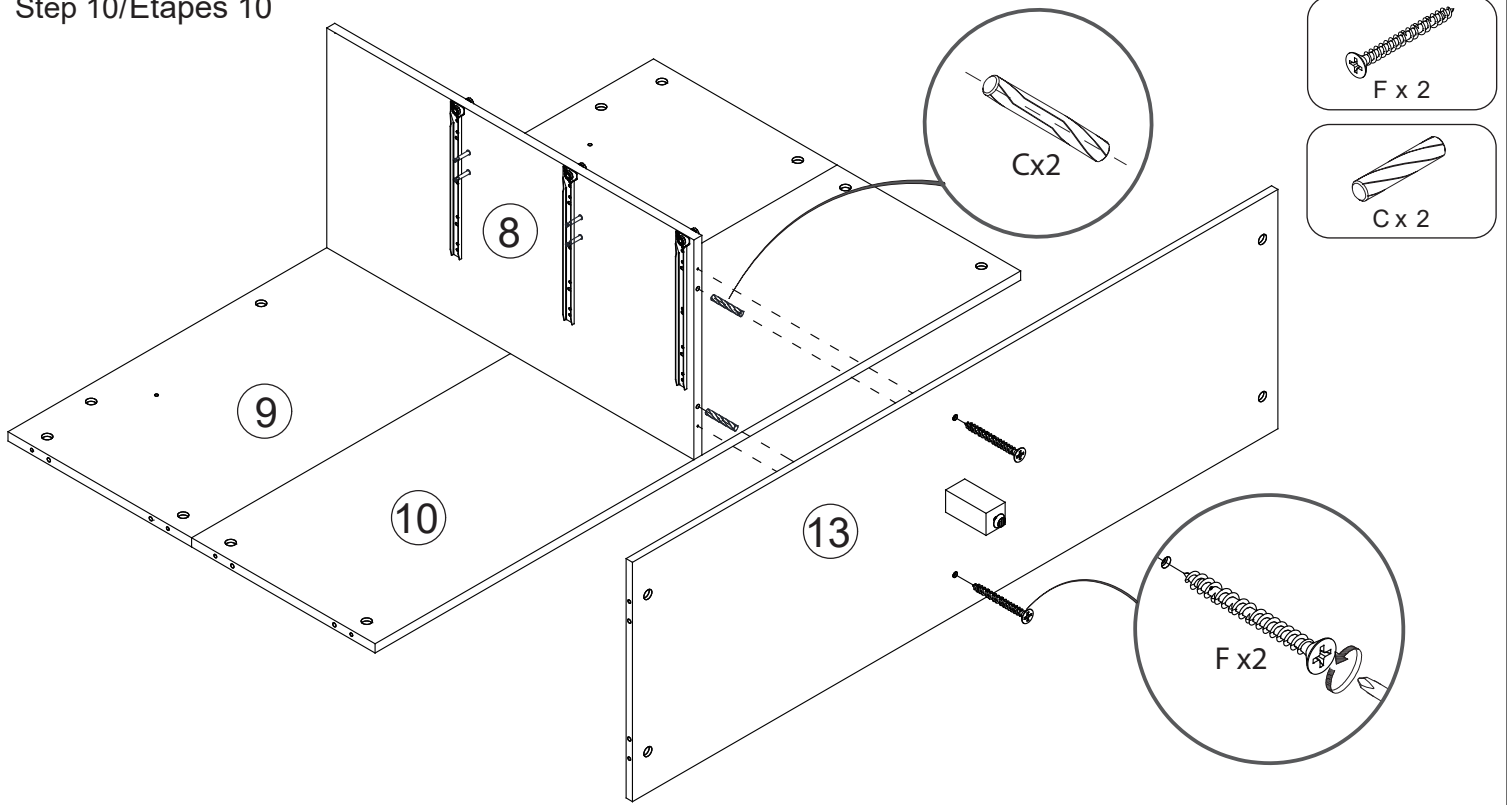

Step 11/Étapes 11

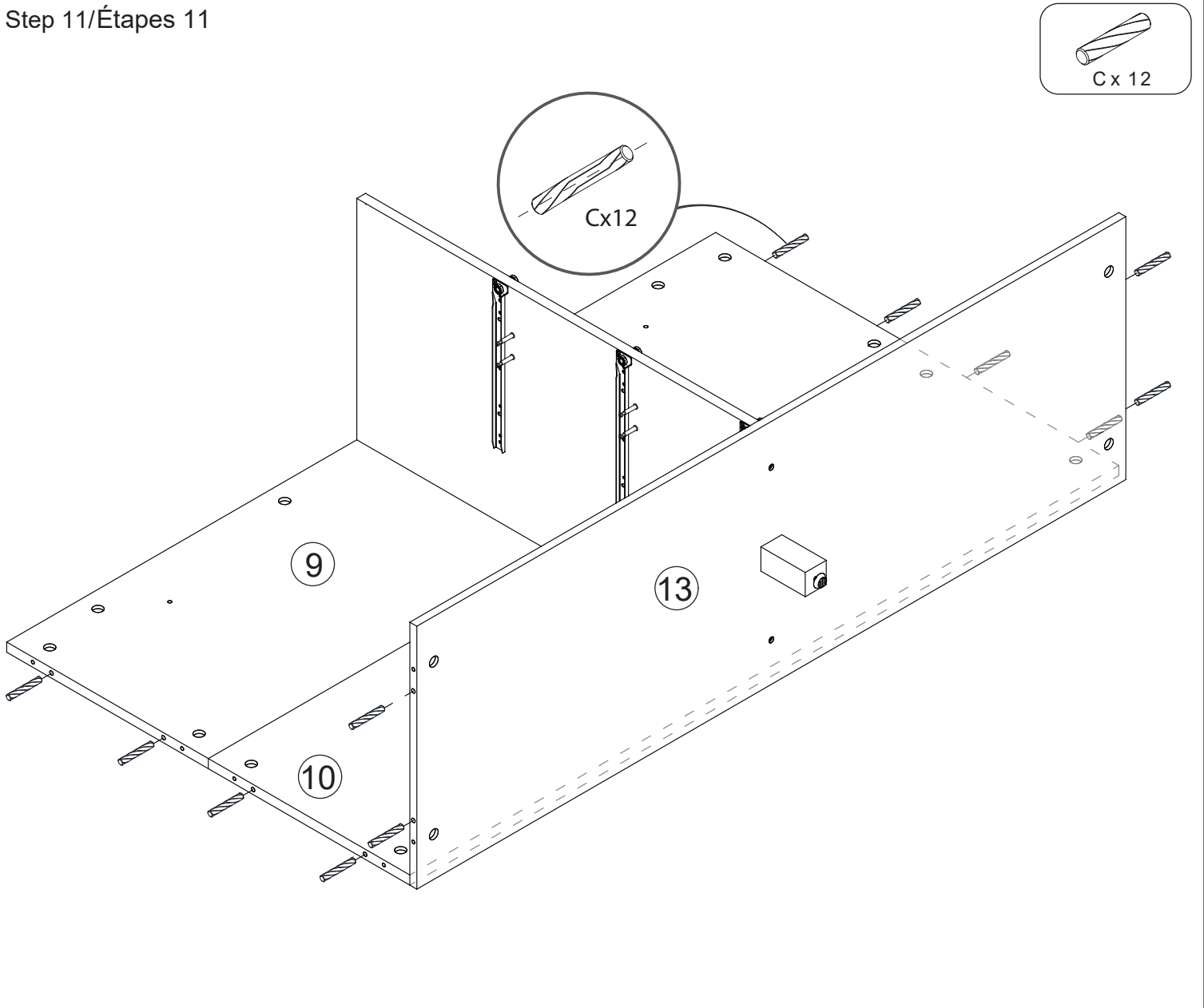

Step 12/Étapes 12

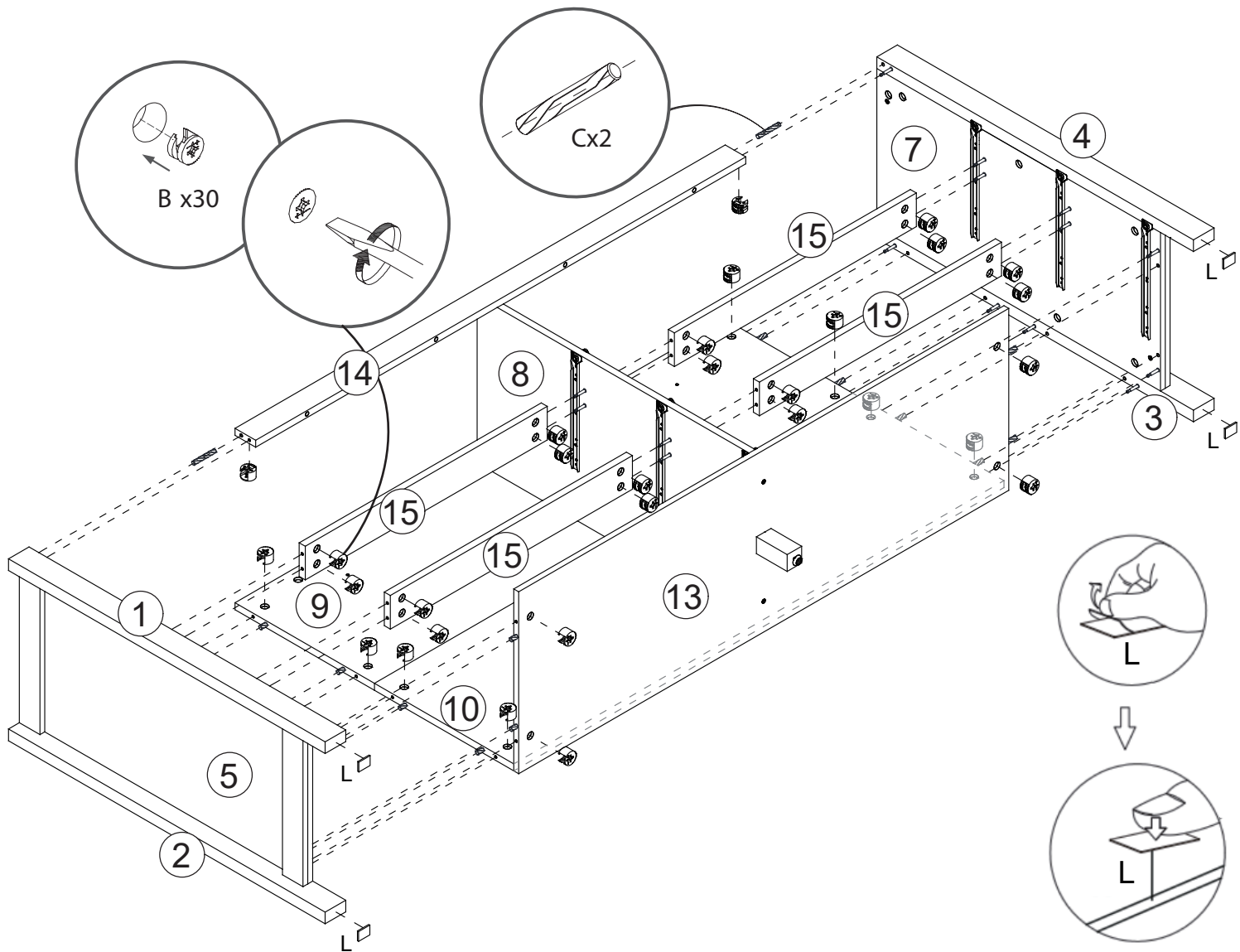
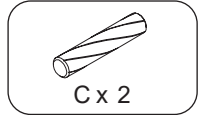
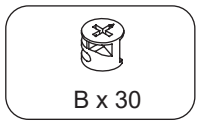
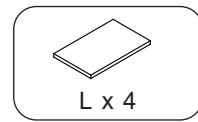

Step 13/Étapes 13

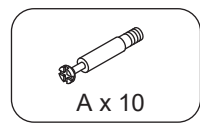
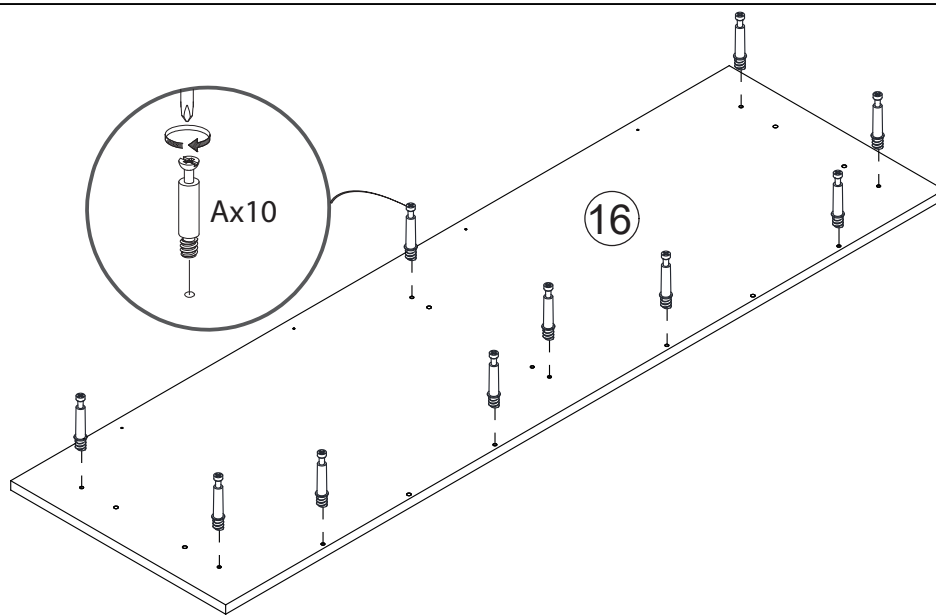

Step 14/Étapes 14

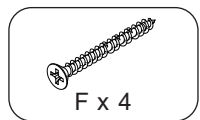
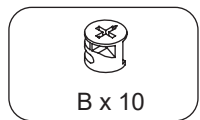
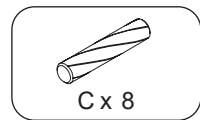
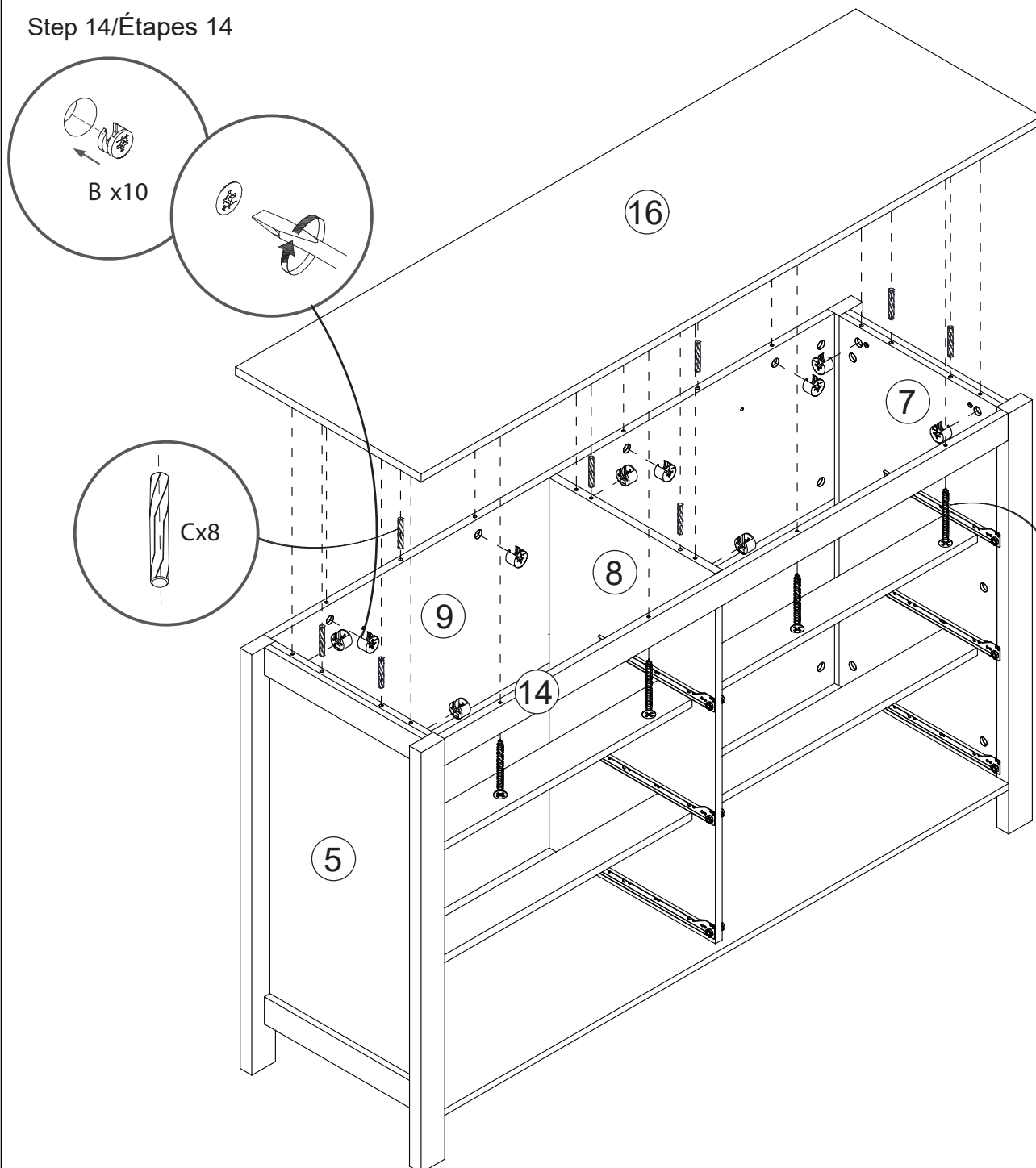

Step 15/Étapes 15

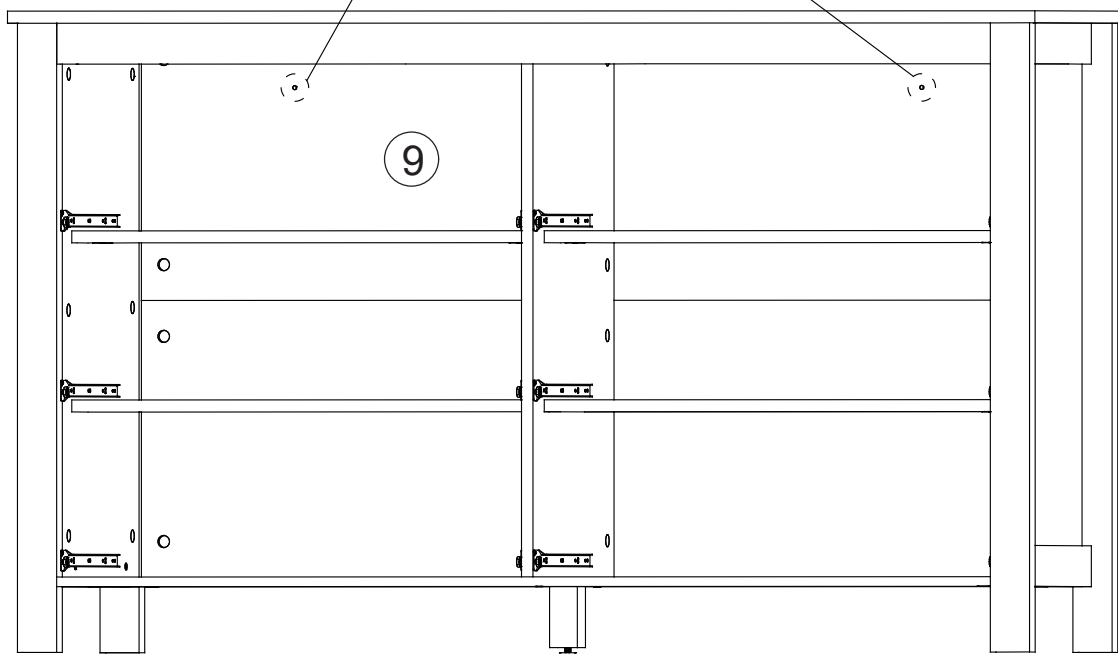
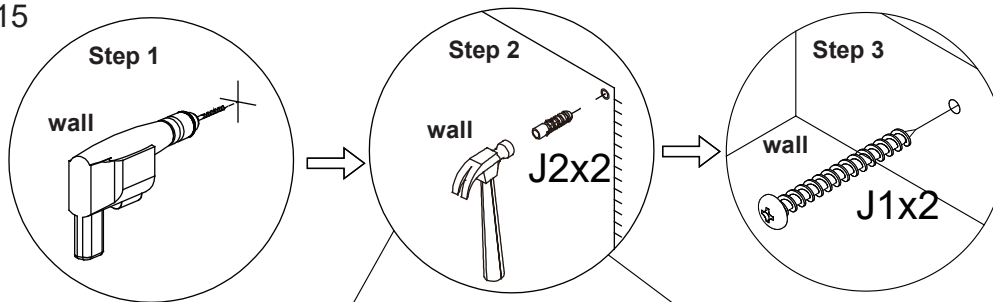

Step 16/Étapes 16

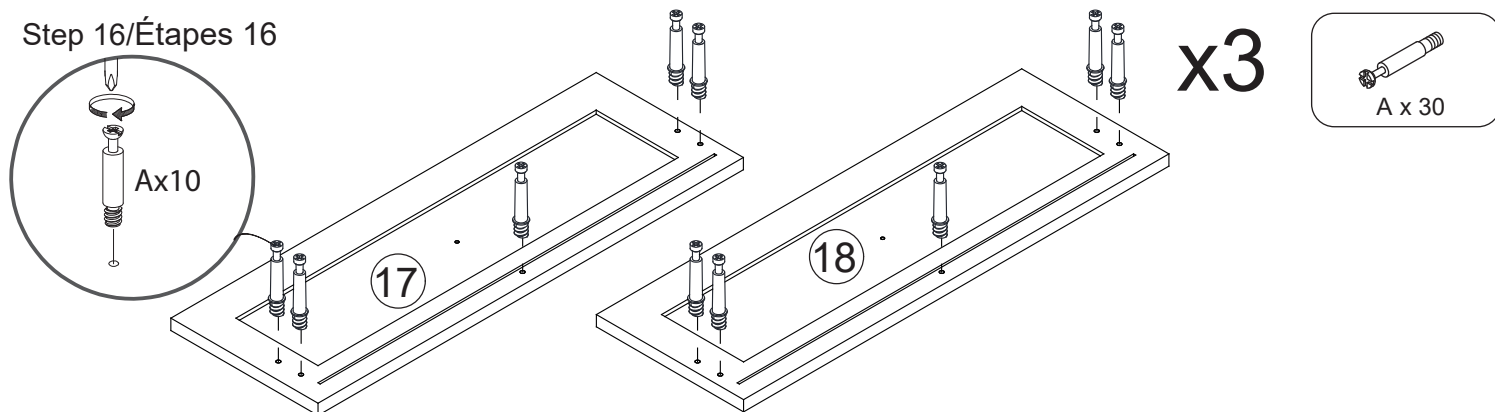

Step 17/Étapes 17

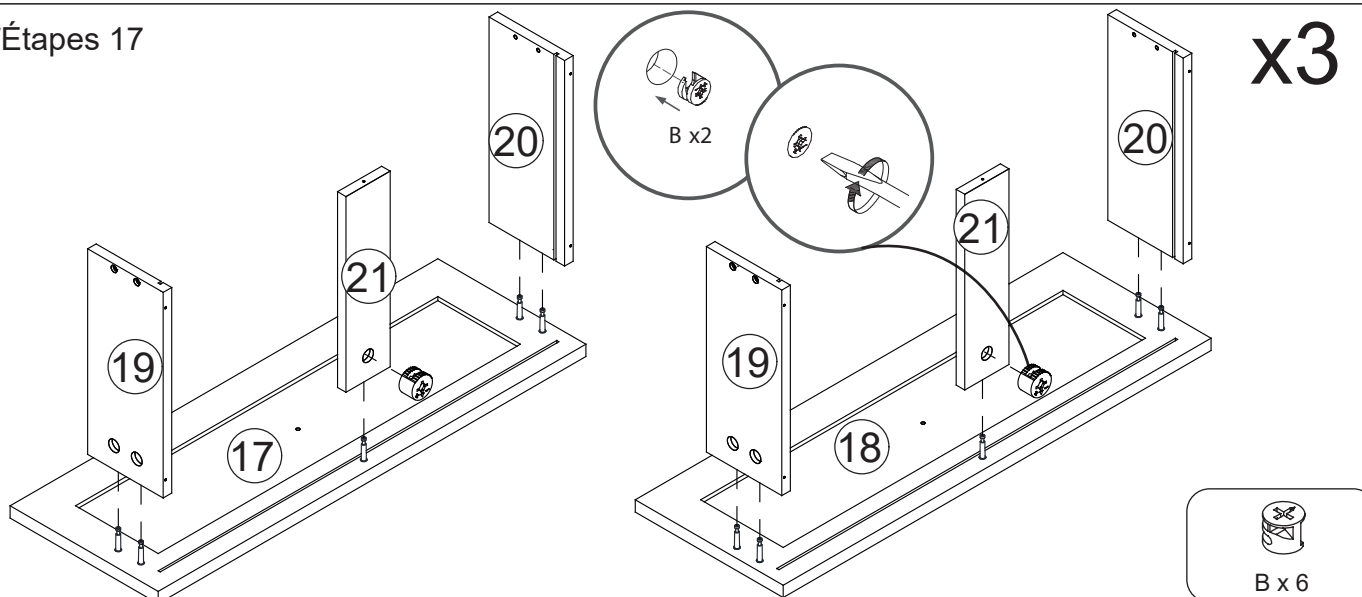

Step 18/Étapes 18

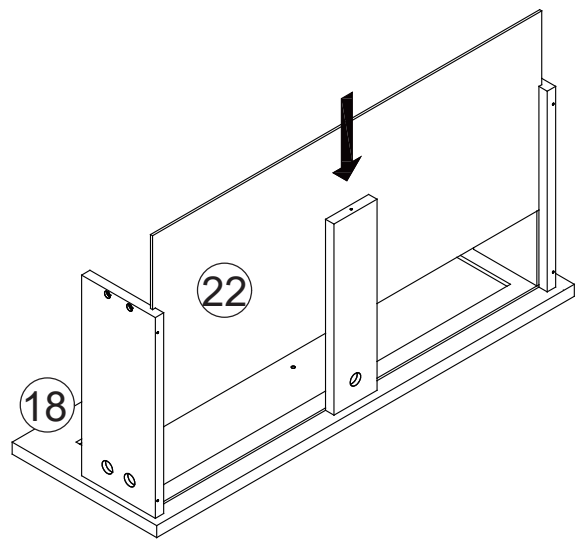
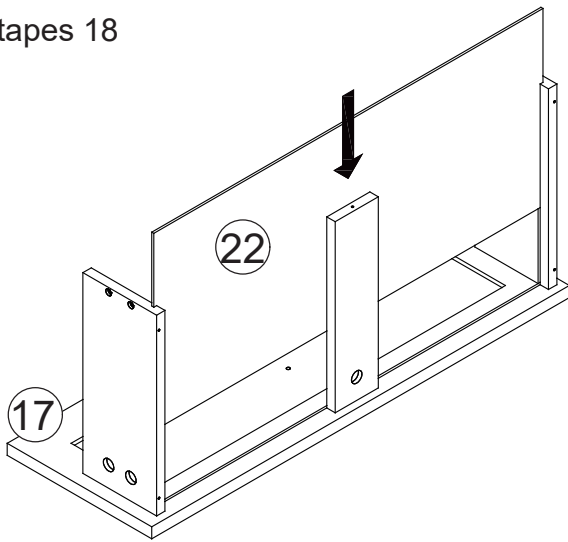

x3

Step 19/Étapes 19

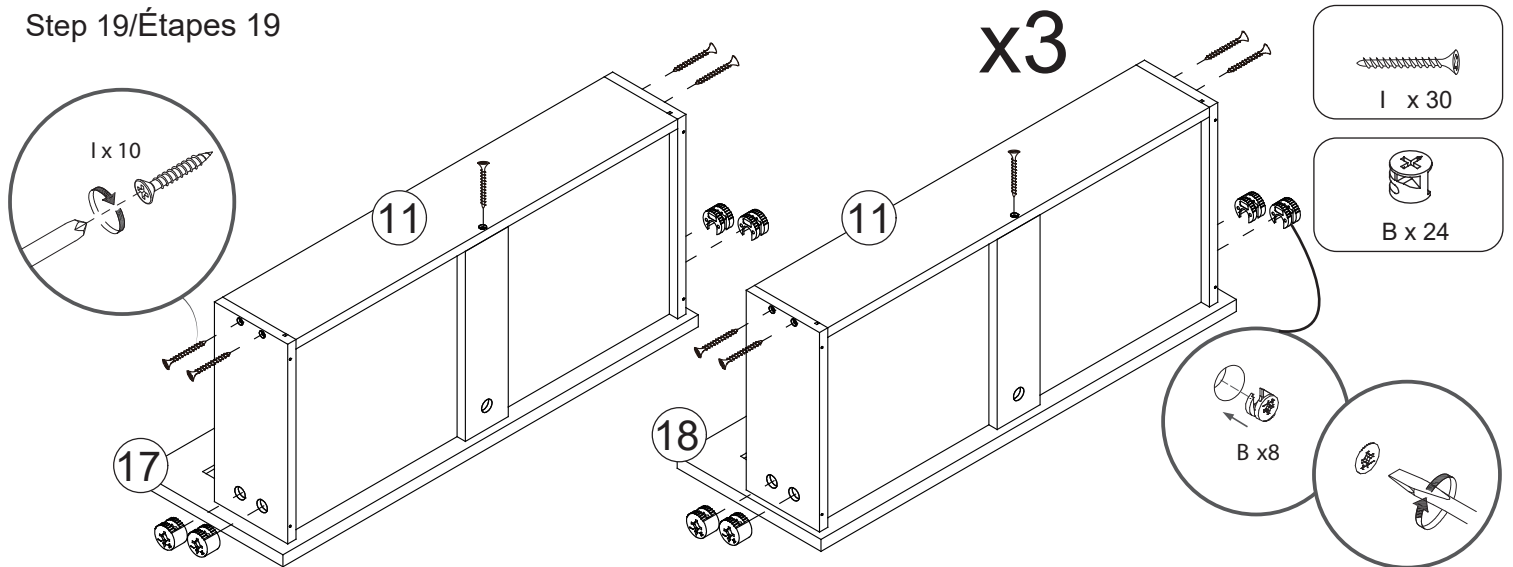

Step 20/Étapes 20

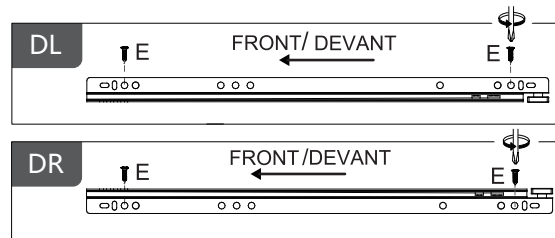

x3

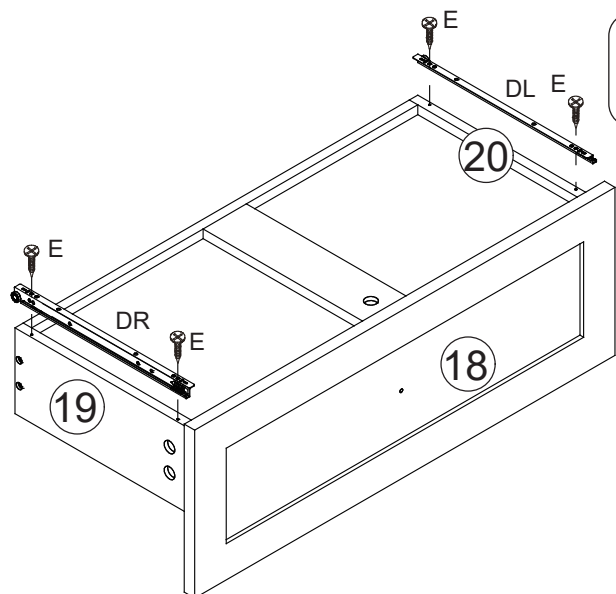
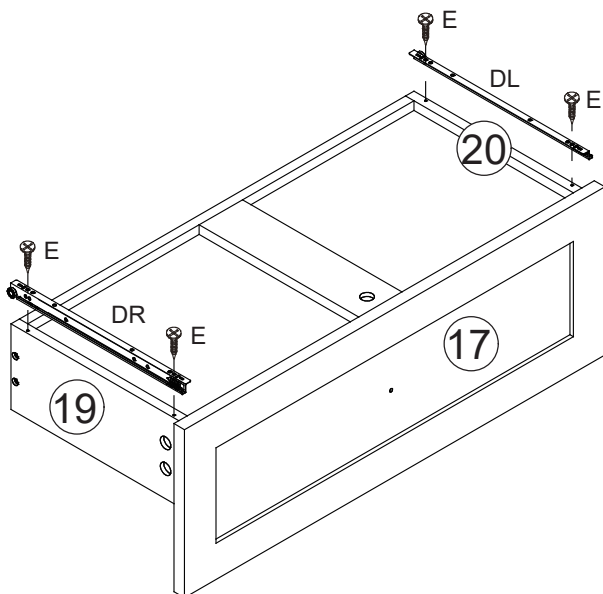
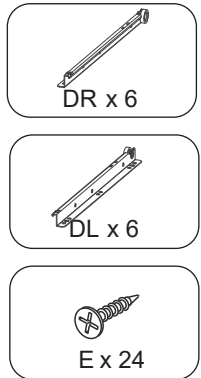

Step 21/Étapes 21

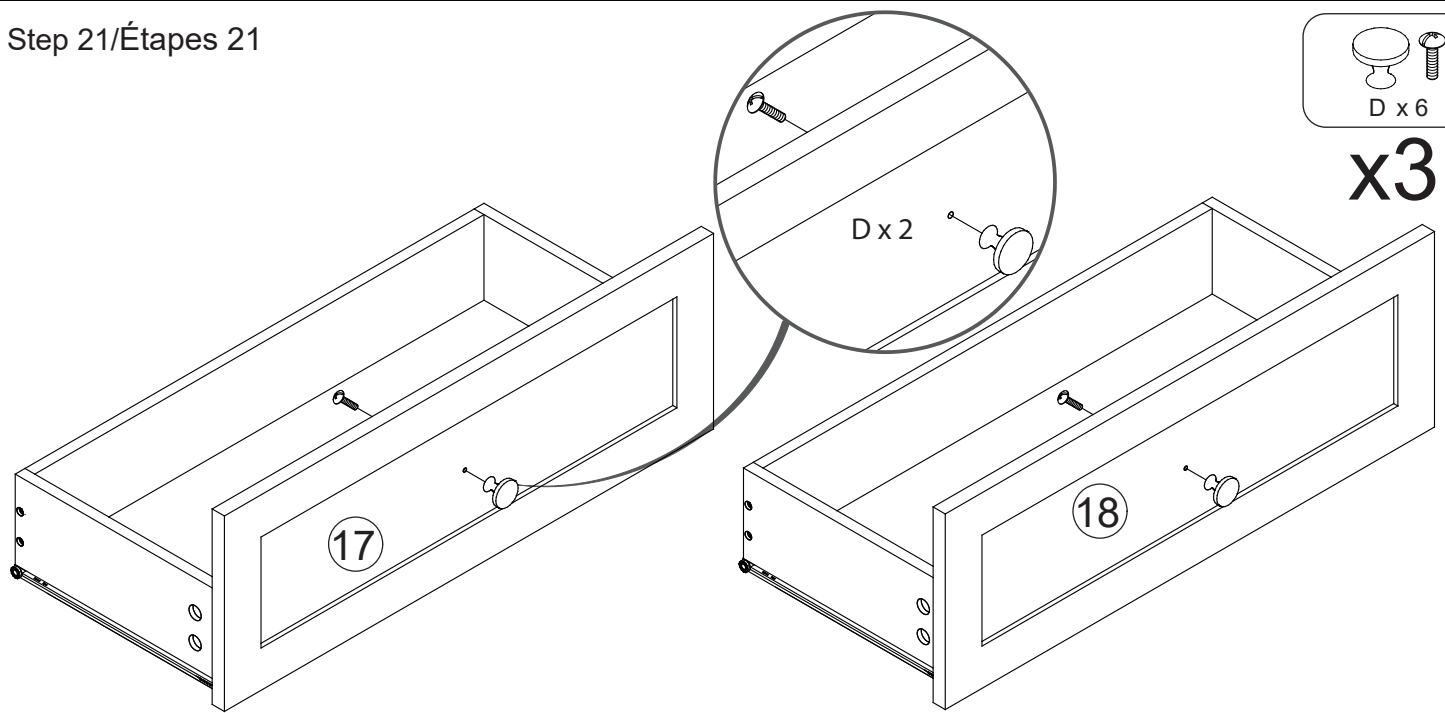

Step 22/Étapes 22

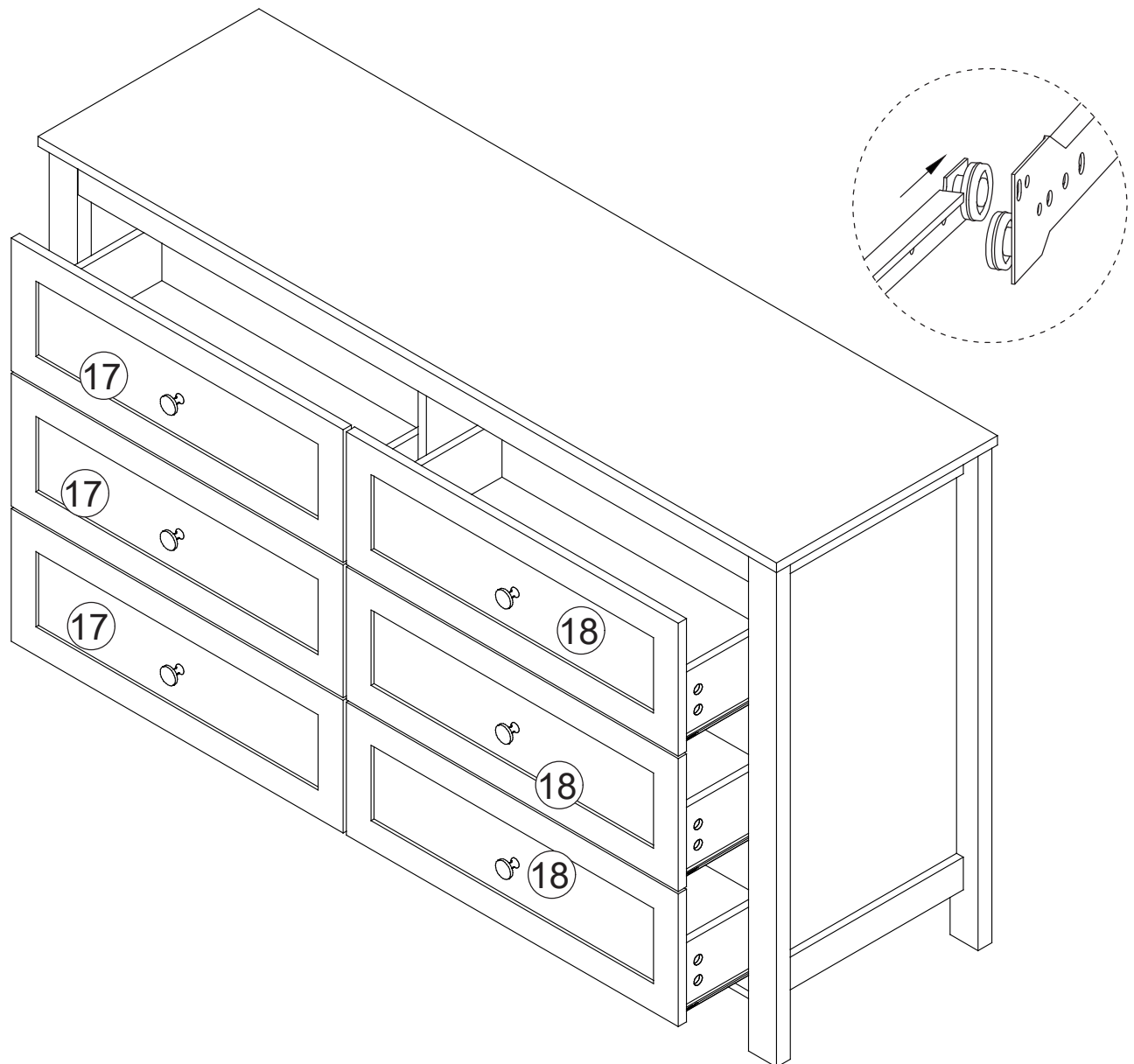



Attention: For safety and stability, we suggest you have to secure the anti-tip accessories to the wall to prevent tipping, injury, and property damage.

Installation Completed



Attention : Pour la sécurité et la stabilité, nous vous suggérons de fixer les accessoires anti-basculement au mur pour éviter le basculement, les blessures et les dommages matériels

Installation terminée